

## **Barlow Solar Energy Centre Consultation Report**

FINAL REPORT



Prepared for:  
Barlow Energy Centre Limited  
Partnership  
53 Jarvis Street, Suite 300  
Toronto, ON M5C 2H2

Prepared by:  
Stantec Consulting Ltd.  
300W-675 Cochrane Drive  
Markham, Ontario L3R 0B8

File No. 160950879  
June 19, 2017

## Sign-off Sheet

This document entitled Barlow Solar Energy Centre Consultation Report was prepared by Stantec Consulting Ltd. ("Stantec") for the account of Barlow Energy Centre Limited Partnership (the "Client"). In connection with the Client's application for a Renewable Energy Approval, this document may be reviewed and used by the following entities in the normal course of their review and approval process: (a) the Ministry of Environment and Climate Change (MOECC); (b) the Ministry of Natural Resources and Forestry (MNRF); (c) the Ministry of Tourism, Culture and Sport (MTC); and (d) the Environmental Review Tribunal. Except as set forth in (a) through (d) above, any reliance on this document by any third party is strictly prohibited. The material in it reflects Stantec's professional judgment in light of the scope, schedule and other limitations stated in the document and in the contract between Stantec and the Client. The opinions in the document are based on conditions and information existing at the time the document was published and do not take into account any subsequent changes. In preparing the document, Stantec did not verify information supplied to it by others, unless otherwise stated therein. Any use which a third party makes of this document is the responsibility of such third party. Such third party agrees that Stantec shall not be responsible for costs or damages of any kind, if any, suffered by it or any other third party as a result of decisions made or actions taken based on this document.

Prepared by \_\_\_\_\_  
  
(signature)

**Mark Knight**  
Senior Environmental Planner

Reviewed and Approved by \_\_\_\_\_  
  
(signature)

**Rob Nadolny**  
Senior Project Manager

## Table of Contents

<b>1.0</b>	<b>INTRODUCTION .....</b>	<b>1.1</b>
1.1	PROJECT OVERVIEW.....	1.1
1.2	REPORT REQUIREMENTS.....	1.1
1.3	PROJECT LOCATION AND STUDY AREA .....	1.2
<b>2.0</b>	<b>CONSULTATION PROCESS.....</b>	<b>2.1</b>
2.1	PROJECT HISTORY AND PREVIOUS CONSULTATION ACTIVITIES.....	2.2
<b>3.0</b>	<b>OVERVIEW OF COMMUNICATION TOOLS .....</b>	<b>3.1</b>
3.3	OVERVIEW OF CONSULTATION ACTIVITIES.....	3.2
<b>4.0</b>	<b>NOTICES OF PROJECT AND MEETINGS.....</b>	<b>4.1</b>
4.1	PRE-DISCLOSURE .....	4.1
4.2	PROJECT DISTRIBUTION LIST .....	4.1
4.2.1	Assessed Landowners and Local Community.....	4.2
4.2.2	Agencies.....	4.2
4.2.3	Municipalities.....	4.2
4.2.4	Aboriginal Communities .....	4.2
4.2.5	Other interested Stakeholders .....	4.3
4.3	PROJECT NOTICES, LETTERS, AND NEWSLETTERS.....	4.3
4.3.1	Notice of Proposal to Engage in a Renewable Energy Project, and First Public Meeting .....	4.3
4.3.2	Notice of Final Public meeting .....	4.3
<b>5.0</b>	<b>PUBLIC CONSULTATION .....</b>	<b>5.1</b>
5.1	OVERVIEW.....	5.1
5.2	PUBLIC MEETINGS.....	5.1
5.2.1	First Public Meeting – October 5, 2016 and October 6, 2016, 4:00-8:00pm .....	5.1
5.2.2	Final Public Meeting – April 24, 2017 and April 25, 2017, 4:00- 7:00pm .....	5.2
5.3	RELEASE OF DRAFT REA REPORTS .....	5.3
5.4	CONSIDERATION OF PUBLIC COMMENTS.....	5.4
5.4.1	Public.....	5.4
5.4.2	Utilities and Other Authorities.....	5.7
<b>6.0</b>	<b>AGENCY AND MUNICIPAL CONSULTATION .....</b>	<b>6.1</b>
6.1	PROJECT NOTIFICATION AND GENERAL CORRESPONDENCE .....	6.1
6.2	AGENCY AND AUTHORITY CONSULTATION .....	6.1
6.2.1	Agency and Authority Distribution List.....	6.1
6.2.2	Summary of Key Correspondence and Consideration of Key Comments.....	6.1
6.3	MUNICIPAL CONSULTATION .....	6.3

**BARLOW SOLAR ENERGY CENTRE  
CONSULTATION REPORT**

6.3.1	Notices and Municipal Consultation Form Distribution .....	6.3
6.3.2	Summary of Key Correspondence and Consideration of Key Comments .....	6.4
<b>7.0</b>	<b>ABORIGINAL ENGAGEMENT.....</b>	<b>7.1</b>
7.1	IDENTIFICATION OF ABORIGINAL COMMUNITIES WITH AN INTEREST IN THE PROJECT.....	7.1
7.2	COMMUNICATION ACTIVITIES .....	7.2
7.2.1	Notice of Proposal to Engage in a Renewable Energy Project and Notice of First Public Meeting .....	7.2
7.2.2	Notice of Final Public Meeting and draft REA Reports.....	7.2
7.2.3	Local Newspaper Notices .....	7.2
7.2.4	Project Telephone, E-mail, Mail, Newsletter and Website .....	7.2
7.2.5	Draft REA Reports.....	7.3
7.3	OVERVIEW OF ABORIGINAL ENGAGEMENT .....	7.3
7.3.1	Mohawks of Akwesasne .....	7.3
7.3.2	Nation Huronne Wendat .....	7.5
7.3.3	Algonquins of Ontario.....	7.5
7.3.4	Algonquins of Pikwàkanagàn First Nation.....	7.6
7.3.5	Métis Nation of Ontario.....	7.7
7.3.6	Summary of Key Correspondence and Consideration of Key Comments.....	7.8
<b>8.0</b>	<b>PLAN FOR ONGOING CONSULTATION .....</b>	<b>8.1</b>
8.1	FINAL REA REPORTS.....	8.1
8.2	COMMUNITY UPDATES.....	8.1
8.3	COMMUNICATION PLAN FOR EMERGENCIES .....	8.1
8.4	COMMUNICATIONS AND ISSUE RESPONSE PROTOCOL.....	8.2
<b>9.0</b>	<b>CLOSURE.....</b>	<b>9.1</b>

**LIST OF TABLES**

Table 1.1:	Consultation Report Requirements (as per O. Reg. 359/09 s. 64.2– Table 1) .....	1.2
Table 3.1:	REA Required Consultation Activities.....	3.2
Table 5.1:	First Public Meeting: Key Information.....	5.2
Table 5.2:	Final Public Meeting: Key Information .....	5.3
Table 5.3:	Key Comments from the Public and Consideration by the Project Team.....	5.5
Table 6.1:	Key Comments from Agencies and Consideration by the Project Team.....	6.2
Table 7.1:	Key Comments from Aboriginal Contacts and Consideration by the Project Team .....	7.8



**BARLOW SOLAR ENERGY CENTRE  
CONSULTATION REPORT**

**LIST OF APPENDICES**

**APPENDIX A PUBLIC MEETING NOTICES, LETTERS, AND NEWSLETTERS**

**APPENDIX B PUBLIC MEETING DISPLAY BOARDS**

**APPENDIX C COMMENT AND RESPONSE TABLE**

**APPENDIX D PROJECT DISTRIBUTION LIST**

**APPENDIX E ADDITIONAL MUNICIPAL CORRESPONDENCE**

**APPENDIX F PRE-REA CONSULTATION MATERIALS**

# BARLOW SOLAR ENERGY CENTRE CONSULTATION REPORT

Introduction  
June 19, 2017

## 1.0 INTRODUCTION

### 1.1 PROJECT OVERVIEW

Barlow Energy Centre Limited Partnership (the Proponent), is proposing the development of a 10-megawatt alternating current (MWac) solar energy generating facility, known as the Barlow Solar Energy Centre (the Project) approximately 10 kilometres (km) west of the city of Cornwall in the Township of South Stormont, United Counties of Stormont, Dundas and Glengarry, Ontario. The Point of Common Coupling will be located within the road allowance of Cornwall Centre Road in the City of Cornwall, Ontario.

The Project will require a Renewable Energy Approval (REA) as per Ontario Regulation 359/09 (O. Reg. 359/09) - under Part V.0.1 of the Environmental Protection Act (MOECC 2009, amended 2016).

The Proponent is proposing to develop, construct, and operate the Project on 38 hectares (ha; 94 acres) of land in response to the Government of Ontario's Large Renewable Procurement (LRP) initiative to promote the development of renewable electricity in the province.

The Proponent has retained Stantec to prepare a REA application, as required under O. Reg. 359/09. The proposed solar PV distribution grid connected system would be considered a Class 3 Solar Facility under O. Reg. 359/09, s. 4. This Consultation Report has been prepared in accordance with O. Reg. 359/09, and is one component of the REA application for the Project.

### 1.2 REPORT REQUIREMENTS

The purpose of this Consultation Report is to provide the Ministry of the Environment and Climate Change (MOECC) with information on consultation activities conducted with respect to the Project. The Consultation Report documents how the Proponent consulted with the public, agencies, and municipalities, and engaged with Aboriginal communities.

O. Reg. 359/09 sets out specific content requirements for the Consultation Report as provided in the MOECC's Checklist for Requirements under O. Reg. 359/09, which has been included as a supplement to the REA application for the Project. **Table 1.1** summarizes the requirements of this report for a Class 3 solar facility as specified under O. Reg. 359/09, and provides a cross-reference of where the information can be found in this report.

**BARLOW SOLAR ENERGY CENTRE  
CONSULTATION REPORT**

Introduction  
June 19, 2017

**Table 1.1: Consultation Report Requirements (as per O. Reg. 359/09 s. 64.2– Table 1)**

Requirement	Section Reference
A summary of communication with any members of the public, aboriginal communities, municipalities, local roads boards and Local Services Boards regarding the project.	Table 5-3, Table 6-1, Table 6-2, Section 7.3, Appendix C
Evidence that the information required to be distributed to aboriginal communities under subsection 17 (1) was distributed.	Section 7, Appendix A, Appendix C
Any information provided by an aboriginal community in response to a request made under paragraph 4 of subsection 17 (1).	Section 7, Appendix C
Evidence that a consultation form was distributed in accordance with subsection 18 (1).	Appendix E
The consultation form distributed under subsection 18 (1), if any part of it has been completed by a municipality, local roads board or Local Services Board.	No form has been completed by a municipality to-date
A description of whether and how, i. comments from members of the public, aboriginal communities, municipalities, local roads boards and Local Services Boards were considered by the person who is engaging in the project, ii. the documents that were made available under subsection 16 (5) were amended after the final public meeting was held, and iii. the proposal to engage in the project was altered in response to comments mentioned in subparagraph i.	i. Table 5-3, Table 6-1, Table 6-2, Section 7.3, Appendix C ii. N/A ii. N/A

The appendices for the Consultation Report are as follows:

- Appendix A: Public Meeting Notices, Letters, and Newsletters
- Appendix B: Public Meeting Display Boards
- Appendix C: Comment and Response Tables
- Appendix D: Project Distribution List
- Appendix E: Additional Municipal Correspondence
- Appendix F: Pre-REA Consultation Materials

### **1.3 PROJECT LOCATION AND STUDY AREA**

The Project is located in the Township of South Stormont within the United Counties of Stormont, Dundas and Glengarry and the site access, part of the Connection Line, and Point of Common Coupling (i.e., point at which Hydro One will connect to the Project) are located in the City of Cornwall. A Trans Northern Pipeline Inc. pipeline and Hydro One transmission line bisect the Project. The Point of Common Coupling will be located within the Project Location, within the road allowance of Cornwall Centre Road in the City of Cornwall. A 300m buffer surrounding the Project Location has been applied, as outlined in O. Reg. 359/09 and the MOECC’s “Technical Guide to Renewable Energy Approvals” (2013). This buffer has been applied for visual purposes



## BARLOW SOLAR ENERGY CENTRE CONSULTATION REPORT

Introduction  
June 19, 2017

only, and does not create any new obligations or change the land use for associated neighboring lands outside the Project Location.

The term "Project Location" is defined by O. Reg. 359/09 as:

*"a part of land and all or part of any building or structure in, on or over which a person is engaging in or proposes to engage in the project and any air space in which a person is engaging in or proposes to engage in the project" (MOECC 2009, amended 2016).*

The current Project Location generally consists of the parcel boundary on which the solar facility will be located and the land associated with the connection line and Point of Common Coupling. The Project Location has been refined to optimize the Project and minimize environmental effects, as determined following field studies and Project layout design.



# BARLOW SOLAR ENERGY CENTRE CONSULTATION REPORT

Consultation Process  
June 19, 2017

## 2.0 CONSULTATION PROCESS

Consultation is a requirement of the REA process under O. Reg. 359/09. Consultation helps to make sure that interests regarding the Project are identified early and addressed. Consultation is also used to identify potentially interested parties and the nature of their interest, inform these parties of the Project, and incorporate their interests into the planning and design process, to the extent possible and as appropriate. In addition, it allows for the development of relationships between the Proponent and interested parties, and establishes opportunities for invaluable feedback to the Project Team. The consultation process is designed to assist in the identification of potential environmental and socio-economic issues so that they are given appropriate consideration in Project planning, design, construction, operation, and decommissioning.

The objectives of the consultation process for the Project were as follows:

- build and maintain community support and obtain the relevant approvals for the Project
- provide relevant, accurate, and consistent information about the Project to local Aboriginal communities, community members, members of the public, agencies, and the municipalities, as early as possible
- obtain/identify relevant information and local knowledge in possession of the local communities, municipalities, and Aboriginal communities
- identify potential issues and areas of concern that may arise from the Project
- address interests by way of providing additional information, explanation, changing Project design or making commitments in response to local input and comments
- develop user-friendly and publicly accessible Project information to allow opportunities for interested stakeholders and Aboriginal communities to understand the Project
- provide opportunities for interested stakeholders and Aboriginal communities to contribute to the collection and sharing of information related to the potential environmental, economic, social, and cultural heritage impacts of the Project
- collect, respond to and document public input and interests

Consultation that was completed for the Project included the mandatory requirements for consultation set out in O. Reg. 359/09.

Consultation for the Project began early in the planning process and will continue throughout the design, development, construction, operation and decommissioning of the Project.



## **BARLOW SOLAR ENERGY CENTRE CONSULTATION REPORT**

Consultation Process  
June 19, 2017

### **2.1 PROJECT HISTORY AND PREVIOUS CONSULTATION ACTIVITIES**

In 2015, the Proponent conducted consultation activities for the Barlow Solar Energy Centre as part of the Independent Electricity System Operator's Large Renewable Procurement 1 Request for Proposals process. This was a competitive procurement process, which included requirements for early consultation.

As part of its work in developing a proposal in response to the LRP 1 RFP, Barlow Energy Centre Limited Partnership developed a Community Engagement Plan (the "Plan"). This Plan set forth the engagement process during the LRP process, outlined a preliminary list of Aboriginal communities and other stakeholders that should be consulted for the Project, and established a forward-looking outline for consultation throughout the life of the Project.

Known, interested parties were identified in the Community Engagement Plan and during the LRP 1 RFP process. In addition, additional parties were identified during consultation that occurred at that time.

The LRP 1 RFP rules outlined consultation requirements which had to be met prior to proposal submission, including specific stakeholders that had to be contacted. In addition to those stakeholders identified in the LRP 1 RFP rules, the Proponent proactively engaged with additional members of the community whom they believed would be interested in the Project.

During the LRP 1 RFP, the Proponent widely advertised and provided notice of two public meetings in which information about the Project and process were provided to attendees. In addition, the information was provided on the Project website.

The Community Engagement Plan, public meeting materials, and public meeting summaries have been included in Appendix F.

Interested parties from the LRP 1 RFP process were carried forward, as appropriate, into consultation on the Project for the REA.

## **3.0 OVERVIEW OF COMMUNICATION TOOLS**

The following sections provide an overview of the tools used to communicate with the public, agencies, municipalities, and Aboriginal communities and how these tools were used over the course of consultation for the Project.

### **3.1 COMMUNICATION TOOLS USED FOR CONSULTATION**

The intent of the consultation process is to provide the community with an overview of the Project scope and apply community responses in all facets of the Project's design and development as early and transparently as possible. Therefore, Barlow Energy Centre Limited Partnership used various communication tools for disseminating Project information, and for ongoing collection of information from interested parties, including but not limited to, the public, agencies, municipalities, and Aboriginal communities.

The communication tools used for the Project include:

- Project notices published in local newspapers
- a Project newsletter distributed by mail and posted on the website page
- direct mailings to assessed landowners in the general vicinity of the Project Study Area
- public meetings
- public meeting comment and questionnaire forms
- a Project website page (<http://www.edf-en.ca/project/barlow-solar-energy-centre/>)
- a Project contact e-mail address (BarlowSolar@edf-en.ca)
- a Project phone number (1-844-55-EDF-EN)
- mailing addresses and telephone numbers for Project staff
- meetings, e-mails and/or phone conversations with agencies, local municipal staff (Township and County), the public and Aboriginal communities
- one-on-one meetings, e-mails and/or phone conversations with participating landowners and potentially affected neighbouring landowners and groups.

Contact information for Project representatives was included on Project communications provided to the public. A Project website, e-mail, and telephone number will continue to remain active throughout the life of the Project.

# BARLOW SOLAR ENERGY CENTRE CONSULTATION REPORT

Overview of Communication Tools  
June 19, 2017

## 3.2 STAKEHOLDER USE OF COMMUNICATION TOOLS

Barlow Energy Centre Limited Partnership responded to questions received during the consultation process for the Project through four public meetings, telephone calls, e-mails, and letters. Consultation activities were designed so that interested parties had an opportunity to provide comments and questions regarding the Project and these communications were tracked through a comment and response table which is appended to this report (**Appendix C**).

## 3.3 OVERVIEW OF CONSULTATION ACTIVITIES

A number of consultation activities were carried out for the Project. **Table 3.1** provides an overview of consultation activities and highlights the timeframe in which these activities were completed in accordance with O. Reg 359/09.

**Table 3.1: REA Required Consultation Activities**

Activity	Timing	Description
Advertising in the local newspaper	September 1, 2016 (34 days prior to First Public Meeting)	Combined First Notice of Proposal and First Notice of First Public Meeting
	September 19, 2016 (16 days prior to First Public Meeting)	Combined Second Notice of Proposal and Second Notice of First Public Meeting
	February 21, 2017 (62 days prior to Final Public Meeting)	Combined First Notice of Draft REA Documents Release and First Notice of Final Public Meeting
	February 23, 2017 (60 days prior to Final Public Meeting)	Combined Second Notice of Draft REA Documents Release and Second Notice of Final Public Meeting
	April 11, 2017 (13 days prior to Final Public Meeting)	Combined Third Notice of Draft REA Documents Release and Third Notice of Final Public Meeting
	TBD (within 10 days of EBR Posting)	Notice of MOECC Review and EBR Posting
Landowner/Public Mailing	August 26, 2016 (40 days prior to First Public Meeting)	Combined Notice of Proposal and Notice of First Public Meeting and Project newsletter
	February 21, 2017 (62 days prior to Final Public Meeting)	Letter with Combined Notice of Draft REA Documents Release, Notice of Final Public Meeting and Project newsletter
Document Releases to the Public	August 26, 2016 (40 days prior to First Public Meeting)	Draft Project Description Report – made available in hard copy at



**BARLOW SOLAR ENERGY CENTRE  
CONSULTATION REPORT**

Overview of Communication Tools  
June 19, 2017

**Table 3.1: REA Required Consultation Activities**

Activity	Timing	Description
		the City of Cornwall and Township of South Stormont Clerk's office and on the Project website
	February 17, 2017 (66 days prior to Final Public Meeting)	Draft REA Documents – made available in hard copy at the City of Cornwall and Township of South Stormont Clerk's office and on the Project website
Public Meeting	October 5 and 6, 2016	First Public Meeting
	April 24 and 25, 2017	Final Public Meeting
Aboriginal Correspondence	August 26, 2016 (40 days prior to First Public Meeting)	Introductory letter, Combined Notice of Proposal and Notice of First Public Meeting, hard copy of the draft PDR and Project newsletter.
	February 16, 2017 (67 days prior to Final Public Meeting)	Letter, Combined Notice of Draft REA Documents Release and Notice of Final Public Meeting and a hard copy of the Draft REA Documents, Project Summary document and Project newsletter.
Municipal Correspondence	August 26, 2016 (40 days prior to First Public Meeting)	Introductory letter accompanied by the Combined Notice of Proposal and First Public Meeting, draft PDR, and Project newsletter.
	August 26, 2016 (City of Cornwall, Township of South Stormont)	Site Plan Approval and Building Permit Request for Determining Noise Receptors
	September 2, 2016 (United Counties of Stormont, Dundas and Glengarry)	
	August 31, 2016 (35 days prior to the First Public Meeting)	Introductory letter accompanied by the Municipal Consultation Form and Project newsletter.
	February 17, 2017 (66 days prior to Final Public Meeting)	Combined Notice of Draft REA Documents Release, Notice of Final Public Meeting, a hard copy of Draft REA Documents and Project newsletter.
Agency Correspondence	July 12, 2016 (113 days prior to First Public Meeting)	Letter to the MOECC, accompanied with a copy of the draft PDR, and request for



**BARLOW SOLAR ENERGY CENTRE  
CONSULTATION REPORT**

Overview of Communication Tools  
June 19, 2017

**Table 3.1: REA Required Consultation Activities**

Activity	Timing	Description
		Aboriginal Community Consultation List
	August 31, 2016 (35 days prior to First Public Meeting)	Combined Notice of Proposal and Notice of First Public Meeting and Project newsletter
	February 21, 2017 (62 days prior to Final Public Meeting)	Combined Notice of Final Public Meeting, Notice of Draft REA Documents Release and Project newsletter
Website ( <a href="http://www.edf-en.ca/project/barlow/">http://www.edf-en.ca/project/barlow/</a> )	August 26, 2016 (40 days prior to First Public Meeting)	Combined Notice of Proposal and Notice of First Public Meeting and Project newsletter
	August 26, 2016 (40 days prior to First Public Meeting)	Draft Project Description Report
	October 12, 2016	First Public Meeting Display Boards
	February 14, 2017 (69 days prior to Final Public Meeting)	Draft REA Documents and Reports
	February 17, 2017 (66 days prior to Final Public Meeting)	Combined Notice of Final Public Meeting, Draft REA Documents Release and Project newsletter
	April 24, 2017	Final Public Meeting Display Boards
	TBD (within 10 days of EBR posting)	Notice of MOECC Review and EBR Posting

Relevant communications were documented and recorded in a summary table with contact information, date, and nature of the communication (**Appendix C**). For the purposes of this Consultation Report, all personal information (i.e. names, contact information) have been removed, as per the federal *Personal Information Protection and Electronic Documents Act* (PIPEDA). Corresponding original communications materials (contact records, letters, emails, questionnaires from public meetings, meeting minutes, etc.) have been filed electronically by Barlow Energy Centre Limited Partnership and Stantec, and are available at the MOECC's request.

# BARLOW SOLAR ENERGY CENTRE CONSULTATION REPORT

Notices of Project and Meetings  
June 19, 2017

## 4.0 NOTICES OF PROJECT AND MEETINGS

### 4.1 PRE-DISCLOSURE

Pre-disclosure includes advance notification of the Project prior to the issuance of the Notice of Proposal to Engage in a Renewable Energy Project. Pre-disclosure activities included submission of the draft Project Description Report (PDR) to the MOECC on July 12, 2016 to obtain the Aboriginal Communities List issued under s.14 (1) (b) of O. Reg. 359/09.

The Notice of Proposal to Engage in a Renewable Energy Project and Municipal Consultation Forms were also provided to the Township of South Stormont and to the City of Cornwall on August 31, 2016 and copies of the draft PDR were couriered to the City of Cornwall and the Township of South Stormont on August 26, 2016. The United Counties of Stormont, Dundas and Glengarry was couriered the Notice of Proposal to Engage in a Renewable Energy Project, the Municipal Consultation Form, the draft PDR, and Project newsletter on September 2, 2016.

Data requests were also made to Ontario Heritage Trust on May 18, 2016, the Ministry of Natural Resources and Forestry on May 31, 2016 and the Ministry of Tourism, Culture and Sport on May 26, 2016.

### 4.2 PROJECT DISTRIBUTION LIST

The Project distribution list was developed in the early stages of the Project (i.e., during the LRP I RFP), and updated as required to identify key contacts that may have a potential interest in the Project. The Project distribution list includes agencies, municipalities, Aboriginal communities, local Conservation Authorities, assessed landowners in the general vicinity of the Project Study Area, and other interested stakeholders that had requested to be placed on the list throughout the REA process. An agency, municipal, Aboriginal community and interested stakeholder distribution list is provided in **Appendix D**.

The Project distribution list was updated throughout the REA process, primarily as a result of attendance at public meetings, where an attendee could indicate their desire to be included on the Project distribution list when signing into the public meeting, and also when completing the contact information section in the public meeting questionnaire.

In addition, the Project distribution list was based on correspondence via letters, e-mail, telephone calls and personal interactions. At an individual's request, a name was either added to or removed from the Project distribution list. Changes to the list were made at the direction of these groups.

## BARLOW SOLAR ENERGY CENTRE CONSULTATION REPORT

Notices of Project and Meetings  
June 19, 2017

### 4.2.1 Assessed Landowners and Local Community

O. Reg. 359/09 requires that for solar projects, all landowners within 120m of the Project Location be contacted, in addition to assessed owners of land abutting a parcel of land on which the Project Location is situated. This was undertaken, in addition to providing notice to all assessed landowners within 150m of the Project Location.

### 4.2.2 Agencies

Agencies that are required contacts as per O. Reg. 359/09 were included on the Project distribution list. In addition, agencies that typically and historically have had an interest in environmental assessment and solar projects based on Stantec's experience were added to the Project distribution list. These include agencies that may issue permits or approvals, as well as agencies that may have an interest in commenting on the Project. Local conservation authorities were also included on the Project distribution list.

### 4.2.3 Municipalities

The Project is located in the Township of South Stormont within the United Counties of Stormont, Dundas and Glengarry and the site access, part of the Connection Line, and Point of Common Coupling (i.e., point at which Hydro One will connect to the Project) are located in the City of Cornwall. The Clerks for the City of Cornwall, the Township of South Stormont and the United Counties of Stormont, Dundas and Glengarry were included on the Project distribution list, as required by O. Reg. 359/09. Other relevant contacts at municipal offices were also added to the Project distribution list.

### 4.2.4 Aboriginal Communities

On June 14, 2016, the draft Project Description Report was sent to the Director of the MOECC to obtain the Aboriginal Communities List as per s. 14 (1) (b) of O. Reg. 359/09. The list was received from the MOECC on August 10, 2016.

Aboriginal communities identified by the MOECC included:

- Mohawks of Akwesasne
- Nation Huronne Wendat

Prior to receiving the Aboriginal Communities list for the Project from the MOECC, Stantec developed a contact list of Aboriginal communities, based on best professional judgement, which included a focus on communities within 100 km of the Project Study Area.

Aboriginal communities identified by the Proponent for initial consultation included:

- Algonquins of Ontario





## BARLOW SOLAR ENERGY CENTRE CONSULTATION REPORT

Notices of Project and Meetings  
June 19, 2017

- Algonquins of Pikwàkanagàn First Nation
- Métis Nation of Ontario
- Mohawks of Akwesasne

### 4.2.5 Other interested Stakeholders

In addition, potentially interested stakeholders including Hydro One, Trans-Northern Pipelines Inc. and NAV Canada were added to the Project distribution list and provided with information about the Project.

The secretary of every company operating an oil or natural gas pipeline located within 200 m of the Project Location were included on the Project distribution list, as required by O. Reg. 359/09.

## 4.3 PROJECT NOTICES, LETTERS, AND NEWSLETTERS

Project Notices were published in local newspapers and mailed, e-mailed, or couriered to the Project distribution list. Notices were also posted on the Project website.

### 4.3.1 Notice of Proposal to Engage in a Renewable Energy Project, and First Public Meeting

The Notice of Proposal to Engage in a Renewable Energy Project and Notice of First Public Meeting was published in the Cornwall Standard-Freeholder on September 1, 2016 and on September 19, 2016. The Notice was published in local newspapers more than thirty (30) days prior to the public meeting dates of October 5, 2016 and October 6, 2016.

The Notice was also directly mailed or e-mailed where preferred, between August 31, 2016 and September 2, 2016 to the Project distribution list. A cover letter was provided to Aboriginal communities and municipal contacts. A Project newsletter accompanied the Notice.

The Notice, as well as the Draft Project Description Report (dated August 2016), were posted on the Project website on August 26, 2016.

A copy of the Notice, letters and newsletter can be found in **Appendix A**.

### 4.3.2 Notice of Final Public meeting

The Notice of Final Public Meeting included information about the final public meeting and the location where the Draft REA Reports were available for public review and comment.

The Notice was published in the Cornwall Standard-Freeholder on February 21, 2017 and on February 23, 2017 to meet the 60-day notification requirement as per O. Reg. 359/09.



## BARLOW SOLAR ENERGY CENTRE CONSULTATION REPORT

Notices of Project and Meetings  
June 19, 2017

The Notice was also directly mailed or e-mailed where preferred on February 21, 2017 to the Project distribution list. A cover letter was provided to Aboriginal communities and landowner/public contacts. A Project newsletter accompanied the Notice.

The Notice was posted on the Project website on February 17, 2017. The Notice was re-published in the Cornwall Standard-Freeholder on April 11, 2017.

A copy of the Notice, letters and newsletter can be found in **Appendix A**.

# BARLOW SOLAR ENERGY CENTRE CONSULTATION REPORT

Public Consultation  
June 19, 2017

## 5.0 PUBLIC CONSULTATION

### 5.1 OVERVIEW

The public consultation program undertaken for the Project included the development and maintenance of a Project distribution list which was used to distribute the required notices, newspaper advertisements, issuance of Project newsletters and four public meetings. The public consultation activities are described below.

### 5.2 PUBLIC MEETINGS

The public meetings were held at the Best Western Parkway Inn & Conference Centre in Cornwall, Ontario and at the South Stormont Community Hall in Long Sault, Ontario on two separate days. The venues were selected due to their proximity to the Project area, accessibility, and/or size to accommodate any member of the community who wished to attend. The meetings were held in the evening to allow the largest number of people to attend at their convenience. Representatives from Barlow Energy Centre Limited Partnership and Stantec attended all public meetings.

The public meetings were held in a drop-in style open house format where information about the Project was provided on large display boards around the room as well as through the placement of other project related material in a convenient location in the room for the public to review. Members of the Project Team were available for discussion, to answer questions, and seek attendees' feedback regarding the Project. Questionnaire forms were made available at each public meeting and participants were encouraged to complete and submit them either at the public meeting or at a later date using a pre-addressed, stamped envelope.

The questionnaire forms asked participants to document their questions, comments, ideas, issues, or concerns regarding the Project, and gave participants the opportunity to describe their interest in the Project, their opinion about various aspects of the public meeting and whether they wanted to be included on the Project distribution list.

#### 5.2.1 First Public Meeting – October 5, 2016 and October 6, 2016, 4:00-8:00pm

The first set of public meetings was held at the South Stormont Community Hall on October 5, 2016 and at the Best Western Parkway Inn & Conference Centre on October 6, 2016.

The purpose of the first public meeting was to introduce the Project and Project Team to the community, with the intention of providing information as early in the process as possible (**Table 5.1**). The first public meeting provided the opportunity for community members to learn about the Project and the REA process, to ask questions of the Project Team, and to provide input into the Project. This allowed the Project team to consider comments, issues and concerns early in the Project lifecycle, to the extent possible and as appropriate.



# BARLOW SOLAR ENERGY CENTRE CONSULTATION REPORT

Public Consultation  
June 19, 2017

It should be noted that at the first public meeting the preliminary project layout was presented to the public. This activity was proactive and generally not the usual path chosen by renewable energy developers. Usually the project layout is only presented to the public at the final public meeting.

Display boards provided information about the Project, including background information on EDF EN Canada, an overview of the Project, information about solar energy, information about the REA process and construction, preliminary results from environmental and technical studies, local benefits, and preliminary layout.

**Table 5.1: First Public Meeting: Key Information**

<b>Township</b>	City of Cornwall and the Township of South Stormont	
<b>Date</b>	October 5, 2016 and October 6, 2015	
<b>Locations</b>	Best Western Parkway Inn & Conference Centre 151 Vincent Massey Drive Cornwall, Ontario	South Stormont Community Hall 2 Mille Roches Road Long Sault, Ontario
<b>Attendees</b>	6 registered attendees (October 5, 2016). 4 registered attendees (October 6, 2016)	
<b>Feedback Forms Received</b>	<ul style="list-style-type: none"> <li>October 5 – 3 questionnaires filled out</li> <li>October 6 – 2 questionnaires filled out</li> </ul>	
<b>Information Presented and Made Available</b>	<ul style="list-style-type: none"> <li>Display boards (also posted on the Project website page)</li> <li>Staff members from EDF EN Canada and Stantec with relevant experience to answer questions to on project topics</li> <li>Draft Project Description Report</li> <li>Project sign in sheets</li> <li>Questionnaires</li> <li>Project newsletter</li> </ul>	

Display boards presented and made available at the first public meeting are provided in **Appendix B**. Information captured from the public meeting was used by the Project team during Project planning and siting where appropriate and within the REA Reports. Comments received from the first public meeting along with the related responses are summarized in **Appendix C** and in **Table 5.3**.

## 5.2.2 Final Public Meeting – April 24, 2017 and April 25, 2017, 4:00-7:00pm

The final public meetings were held at the Best Western Parkway Inn & Conference Centre on April 24, 2017 and at the South Stormont Community Hall on April 25, 2017.

The purpose of the final public meeting was to provide an update on the Project to community members, including any refinements made to the Project layout, the results of the REA studies and the Draft REA Reports, and gather feedback (**Table 5.2**).



**BARLOW SOLAR ENERGY CENTRE  
CONSULTATION REPORT**

Public Consultation  
June 19, 2017

Display boards provided information about the Project, including background information on EDF EN Canada, an overview of the Project, information on the draft REA reports, and an overview of project components including Project layout, solar panels, inverter/transformer skids and substation.

**Table 5.2: Final Public Meeting: Key Information**

Township	City of Cornwall, Township of South Stormont	
Date	April 24, 2017 and April 25, 2017	
Locations	Best Western Parkway Inn & Conference Centre 151 Vincent Massey Drive Cornwall, Ontario	South Stormont Community Hall 2 Mille Roches Road Long Sault, Ontario
Attendees	4 registered attendees (April 24, 2017). 7 registered attendees (April 25, 2017).	
Feedback Forms Received	<ul style="list-style-type: none"> <li>• April 24 – 4 questionnaires filled out</li> <li>• April 25 – 4 questionnaires filled out</li> </ul>	
Information Presented and Made Available	<ul style="list-style-type: none"> <li>• Display boards (also posted on the Project website page)</li> <li>• Staff members from EDF EN Canada and Stantec with relevant experience to answer questions to on project topics</li> <li>• Draft REA Reports</li> <li>• Project sign in sheets</li> <li>• Questionnaires</li> <li>• Project Newsletter</li> </ul>	

Display boards presented and made available at the final public meeting are provided in **Appendix B**. Information captured from the final public meeting was considered by the Project team when finalizing the Project site plan and REA Reports, as appropriate. All attendees were encouraged to complete a questionnaire providing their comments to the Project Team at the meeting, or to return the questionnaire by May 5, 2017, to provide time to incorporate their comments prior to submission of the REA documentation to the MOECC. Comments received from the final public meeting along with the related responses are summarized in **Appendix C** and in **Table 5.3**.

**5.3 RELEASE OF DRAFT REA REPORTS**

The draft Project Description Report (dated August 2016) was posted on the Project website, at least 30 days prior to the first public meeting, in accordance with O. Reg. 359/09. It was also made available at the Township of South Stormont municipal office (2 Mille Roches Rd, Long Sault, ON) and at the City of Cornwall municipal office (360 Pitt St. Box 877, Cornwall, ON) for public review.

The following Draft REA Reports were made available on the Project website, at the Township of South Stormont municipal office (2 Mille Roches Rd, Long Sault, ON) and at the City of Cornwall



# BARLOW SOLAR ENERGY CENTRE CONSULTATION REPORT

Public Consultation  
June 19, 2017

municipal office (360 Pitt St. Box 877 Cornwall, ON), for public review and comment at least 60 days before the final public meeting in accordance with O. Reg. 359/09 between February 22, 2017 and April 23, 2017:

- Project Description Report
- Construction Plan Report
- Design and Operations Report
- Decommissioning Plan Report
- Acoustic Assessment Report
- Natural Heritage Assessment and Environmental Impact Study
- Water Assessment and Water Body Report
- Stages 1 and 2 Archaeological Assessment Report
- REA Checklist: Consideration of Potential for Heritage Resources
- Project Summary Report

A copy of the public review location cover letters used for release of the draft REA reports are provided in **Appendix E**. All other notification occurred in combination with the Notice of Final Public Meeting provided in **Appendix A**.

A Project Summary Report was prepared in accordance with O. Reg. 359/09 for Aboriginal communities and was submitted to the Aboriginal communities at the same time as the draft REA reports.

The commencement of the public review period was at least 60 days prior to the final public meeting, in accordance with s.16 of O. Reg. 359/09. The draft REA Reports will remain on the Project website. Once the MOECC deems the REA application complete, final copies of the REA Reports will be posted on the Project website.

Hard copies of the draft REA Reports and summary reports were also provided to Aboriginal communities for review and comment, with a written request that the information be made available to the communities, as appropriate.

## 5.4 CONSIDERATION OF PUBLIC COMMENTS

### 5.4.1 Public

Information provided by the public assisted in gaining input into the design and planning of the Project. Written and verbal comments received at the public meetings were reviewed by the Project Team and considered during Project siting and planning, and during preparation of the



**BARLOW SOLAR ENERGY CENTRE  
CONSULTATION REPORT**

Public Consultation  
June 19, 2017

REA Reports. One written public comment was received outside of the public meetings prior to May 26, 2017 for incorporation of comments prior to submission of the REA documentation to the MOECC.

A summary of the key public comments and how the Project Team considered comments is provided in **Table 5.3**; including whether:

- the Project or study design was altered in response to comments received
- the REA Reports were amended based on comments received; and/or
- additional information was provided.

Public comments and responses from the start of the REA process in August 2016 to June 14, 2017 are summarized in **Appendix C**.

**Table 5.3: Key Comments from the Public and Consideration by the Project Team**

Key Comments	Project Response	How Comments Were Considered by Project Team
<ul style="list-style-type: none"> <li>• Concern about damage to local roads during construction</li> </ul>	Proponent is engaging with City of Cornwall to implement a roadway damage permit (i.e. agreement to repair roads should they be deteriorated as part of the project).	Required no alterations, amendments, or additional information.
<ul style="list-style-type: none"> <li>• Project interaction and interference with local model planes.</li> </ul>	Additional consultation determined that there will be no interaction or interference.	Provided additional consultation to the Cornwall Aero Modellers club.
<ul style="list-style-type: none"> <li>• Project economics and cost of electricity in Ontario.</li> </ul>	Issues are beyond the scope of this Project.	Required no alterations, amendments, or additional information.
<ul style="list-style-type: none"> <li>• Interest in local procurement and employment opportunities.</li> </ul>	Contact information is being retained for future procurement and employment. EDF EN Canada will encourage the general contractor to host an open house near the Project prior to construction to meet local service providers and interested personnel to encourage local participation in construction activities.	Required no alterations, amendments, or additional information.
<ul style="list-style-type: none"> <li>• Recycling of solar panels.</li> </ul>	Solar panels are either recycled or disposed of in a manner that conforms to all government, environmental and legal requirements.	Required no alterations, amendments, or additional information.



**BARLOW SOLAR ENERGY CENTRE  
CONSULTATION REPORT**

Public Consultation  
June 19, 2017

**Table 5.3: Key Comments from the Public and Consideration by the Project Team**

Key Comments	Project Response	How Comments Were Considered by Project Team
	<p>The standard practice of EDF EN Canada is to negotiate a recycling/disposal provision within their solar panel supply agreements that typically includes recycling and/or disposal and logistics (i.e., who picks up the panels, ships them where, at what cost).</p>	
<ul style="list-style-type: none"> <li>Concern about visual impacts of the Project.</li> </ul>	<p>Trees will be planted along the road at the Project site to eventually minimize visual effects from the Project.</p> <p>There are no neighbors in proximity who can see the Project from their homes.</p>	<p>Required no alterations, amendments, or additional information.</p>
<ul style="list-style-type: none"> <li>Concern about change in ownership during the operations and decommissioning of the Project.</li> </ul>	<p>Project will include a plan for communicating any ownership changes within project asset management documentation.</p> <p>The lease agreement clearly states that project owner needs to remove all equipment from site and restore the land it was in prior to condition prior to construction.</p> <p>Renewable Energy Approval includes a commitment that project components will be removed from site at the end of the project and land restored to condition it was in prior to construction.</p>	<p>Required no alterations, amendments, or additional information.</p>
<ul style="list-style-type: none"> <li>Concerned about traffic disturbance near the project.</li> </ul>	<p>A newsletter will be prepared prior to construction and distributed to project mailing list to indicate whether any traffic disturbances are anticipated and provide further details.</p> <p>Information will also be posted on project website.</p>	<p>Required no alterations, amendments, or additional information.</p>
<ul style="list-style-type: none"> <li>Site re-vegetation following construction.</li> </ul>	<p>Communicating with Raisin Region Conservation Authority to determine appropriate vegetation to integrate beneath solar panels and within site.</p>	<p>Required no alterations, amendments, or additional information.</p>



## BARLOW SOLAR ENERGY CENTRE CONSULTATION REPORT

Public Consultation  
June 19, 2017

### 5.4.2 Utilities and Other Authorities

Barlow Energy Centre Limited Partnership also communicated with relevant local utilities and other authorities that were identified as possibly having an interest in the Project and those that could potentially have information that should be considered in the various Project studies.

The following groups were included on the Project distribution list and were therefore provided all Project Notices:

- Hydro One Networks Inc.
- NAV Canada
- Trans-Northern Pipelines Inc.

Barlow Energy Centre Limited Partnership have undertaken discussions with NAV Canada regarding potential permitting requirements, and Trans-Northern Pipelines Inc. regarding interactions between the Project and existing pipeline, including two proposed pipeline crossing locations within the Project Area. To-date these discussions have required no alterations or amendments to the Project.

## **6.0 AGENCY AND MUNICIPAL CONSULTATION**

The following sections describe communication with agencies and municipalities throughout the REA process.

### **6.1 PROJECT NOTIFICATION AND GENERAL CORRESPONDENCE**

Communication began on July 12, 2016 when the draft Project Description Report was sent to the Director, Approvals Program of the Environmental Assessment and Approvals Branch at the MOECC.

The Notice of Proposal to Engage in a Renewable Energy Project and the Notice of First Public Meeting was distributed on August 31, 2016 to municipalities and the MOECC.

Additional contact with agencies, municipalities and elected officials occurred throughout the course of the Project. This contact included e-mails, letters, telephone correspondence and visits to agency offices to gather and/or clarify information collected for the technical studies.

On February 21, 2017, the Notice of Final Public Meeting was distributed to the MOECC and to municipalities. The Notice also provided details regarding the public locations where the Draft REA Reports could be viewed including a link to the Project website (see Section 4.3).

### **6.2 AGENCY AND AUTHORITY CONSULTATION**

#### **6.2.1 Agency and Authority Distribution List**

The following agencies were engaged at various points throughout the REA process:

- Ministry of Natural Resources and Forestry
- Ministry of the Environment and Climate Change
- Ministry of Tourism, Culture and Sport
- Ontario Heritage Trust
- Raisin Region Conservation Authority

#### **6.2.2 Summary of Key Correspondence and Consideration of Key Comments**

A summary of the comments from agencies, and how the Project Team considered comments, is provided in Error! Reference source not found.1.

Agency comments and responses from the start of the REA process in August 2016 to June 14, 2017 are summarized in **Appendix C**.

**BARLOW SOLAR ENERGY CENTRE  
CONSULTATION REPORT**

Agency and Municipal Consultation  
June 19, 2017

**Table 6.1: Key Comments from Agencies and Consideration by the Project Team**

Agency	Comment	Response	How Comments Were Considered by Project Team
Ministry of Natural Resources and Forestry	<ul style="list-style-type: none"> <li>• Provided comments on the Natural Heritage site investigation work and the NHA/EIS report.</li> <li>• Provided confirmation for the NHA/EIS report.</li> <li>• Providing information regarding MNRF permits.</li> <li>• Confirmed the engineer report requirement for pipelines.</li> </ul>	<ul style="list-style-type: none"> <li>• Provided responses to MNRF to respond to issues raised on the NHA/EIS report.</li> </ul>	<ul style="list-style-type: none"> <li>• Worked collaboratively with MNRF to address any changes to the work program and the NHA/EIS report.</li> <li>• Agreed to create a minimum 5m setback from woodland features on the north side of the Project site.</li> <li>• The NHA/EIS was completed in accordance with MNRF guidelines.</li> <li>• Any permits will be applied for outside of the REA process.</li> </ul>
Ministry of the Environment and Climate Change	<ul style="list-style-type: none"> <li>• Provided Aboriginal Communities List recommended for consultation.</li> <li>• Confirmed methodology (polygon approach) for the Acoustics Assessment.</li> <li>• Offered guidance about various elements of the REA process.</li> <li>• Clarified regulatory requirements, approaches to investigations required for the REA and consultation expectations.</li> </ul>	<ul style="list-style-type: none"> <li>• Barlow Energy Centre Limited Partnership engaged all Aboriginal Communities listed by the MOECC.</li> <li>• Followed advice provided by the MOECC on process suggestions.</li> </ul>	<ul style="list-style-type: none"> <li>• Took all guidance from the MOECC into consideration during Project assessment, design and during preparation of the REA application.</li> </ul>
Ministry of Tourism, Culture and Sport	<ul style="list-style-type: none"> <li>• Provided confirmation that there were no provincial heritage resources within or adjacent to the Project Study Area.</li> <li>• Provided confirmation for</li> </ul>	<ul style="list-style-type: none"> <li>• N/A</li> </ul>	<ul style="list-style-type: none"> <li>• Informed the cultural heritage review.</li> </ul>

**BARLOW SOLAR ENERGY CENTRE  
CONSULTATION REPORT**

Agency and Municipal Consultation  
June 19, 2017

**Table 6.1: Key Comments from Agencies and Consideration by the Project Team**

Agency	Comment	Response	How Comments Were Considered by Project Team
	the archaeology reports.		
Ontario Heritage Trust	<ul style="list-style-type: none"> <li>Provided confirmation that there were no OHT properties within or adjacent to the Project Study Area.</li> </ul>	<ul style="list-style-type: none"> <li>N/A</li> </ul>	<ul style="list-style-type: none"> <li>Informed the cultural heritage review.</li> </ul>
Raisin Region Conservation Authority	<ul style="list-style-type: none"> <li>Provided floodplain data and discussed permit and study requirements related to the project location in a floodplain.</li> <li>Expressed interests regarding groundwater contamination, solar panels contaminating the site, road deterioration, project decommissioning, project financing, chemicals, landscaping, and the agricultural nature of the site.</li> </ul>	<ul style="list-style-type: none"> <li>On-going consultation will occur with the Raisin Region Conservation Authority.</li> </ul>	<ul style="list-style-type: none"> <li>Undertook design measures to address design within the floodplain, such as elevating equipment.</li> <li>Committed to providing a list of chemicals that might be stored on site.</li> <li>Raisin Region Conservation Authority will be involved in site landscaping efforts.</li> <li>Any permits will be applied for outside of the REA process.</li> <li>Added reference to presence of floodplain in REA reports.</li> </ul>

## 6.3 MUNICIPAL CONSULTATION

### 6.3.1 Notices and Municipal Consultation Form Distribution

The Project is located within the Township of South Stormont. The site access, part of the Connection Line, and Point of Common Coupling (i.e., point at which Hydro One will connect to the Project) are located in the City of Cornwall. In addition to Project Meeting notifications (see **Appendix A**), the following correspondence and Project documents were provided for municipal review:

- Draft Project Description Report on August 26, 2016 (letter dated August 25), followed by Municipal Consultation Forms on August 31, 2016, to the City of Cornwall and Township of South Stormont



## BARLOW SOLAR ENERGY CENTRE CONSULTATION REPORT

Agency and Municipal Consultation  
June 19, 2017

- The United Counties of Stormont, Dundas and Glengarry was couriered the Notice of Proposal to Engage in a Renewable Energy Project, the Municipal Consultation Form, the draft PDR, and Project newsletter on September 2, 2016.
- Site Plan Approval and Building Permit Request for determining noise receptors on August 26, 2016 (City of Cornwall, Township of South Stormont) and September 2, 2016 (United Counties of Stormont, Dundas and Glengarry)
- Draft REA reports on February 17, 2017 (City of Cornwall and Township of South Stormont)

Both the Township of South Stormont and the City of Cornwall have passed municipal council resolutions in support of the Project.

Documentation of key correspondence with the municipalities can be found in **Appendix E**.

### 6.3.2 Summary of Key Correspondence and Consideration of Key Comments

Correspondence and meetings have occurred with the municipalities throughout the REA process, and will continue throughout the life of the Project. A summary of the comments from municipalities, and how the Project Team considered comments, is provided in **Table 6.2**.

Municipal meetings, comments, and responses from the start of the REA process in August 2016 to June 14, 2017 are summarized in **Appendix C**.

**Table 6.2: Key Comments from Municipalities and Consideration by the Project Team**

Comment	Project Response	How Comments Were Considered by Project Team
<ul style="list-style-type: none"> <li>• Consult with Raisin Region Conservation Authority regarding development in floodplain.</li> </ul>	<ul style="list-style-type: none"> <li>• Consultation with Raisin Region Conservation Authority on-going.</li> </ul>	<ul style="list-style-type: none"> <li>• See Table 6.1.</li> </ul>
<ul style="list-style-type: none"> <li>• Concern about visual impacts of the Project</li> </ul>	<ul style="list-style-type: none"> <li>• Shipping containers will be screened by fencing or other means.</li> <li>• Trees along project boundary will eventually provide additional screening.</li> </ul>	<ul style="list-style-type: none"> <li>• Project plans will include screening of shipping containers if integrated within the site during final design or integrated at any point of site operation.</li> </ul>
<ul style="list-style-type: none"> <li>• Coordination with Emergency Services regarding design of access roads, training requirements, and development of a response plan.</li> </ul>	<ul style="list-style-type: none"> <li>• A commitment of the Design and Operations Report is the development of an Emergency Response Plan, which will be prepared in consultation with emergency service providers. The Plan will be implemented by any owner of the project, and will</li> </ul>	<ul style="list-style-type: none"> <li>• Will consult with emergency service providers during design of the access road.</li> <li>• Will plan a meeting between local emergency response and project team addressing these items prior to commercial operation.</li> </ul>

**BARLOW SOLAR ENERGY CENTRE  
CONSULTATION REPORT**

Agency and Municipal Consultation  
June 19, 2017

**Table 6.2: Key Comments from Municipalities and Consideration by the Project Team**

Comment	Project Response	How Comments Were Considered by Project Team
	include information on training requirements. <ul style="list-style-type: none"> <li>• Request for input into access road design is noted.</li> <li>• Sharing emergency numbers and procedures with local emergency response.</li> </ul>	
<ul style="list-style-type: none"> <li>• Need to obtain multiple municipal permits</li> </ul>	<ul style="list-style-type: none"> <li>• All necessary municipal permits will be obtained.</li> </ul>	<ul style="list-style-type: none"> <li>• Required no alterations, amendments, or additional information.</li> </ul>
<ul style="list-style-type: none"> <li>• Transition plan for any future ownership changes</li> </ul>	<ul style="list-style-type: none"> <li>• Project will include a plan for communicating any ownership changes within project asset management documentation.</li> </ul>	<ul style="list-style-type: none"> <li>• Required no alterations, amendments, or additional information.</li> </ul>
<ul style="list-style-type: none"> <li>• Concern about potential for damage to local roads during construction (also noted in Table 5.3, as comment noted on a public meeting exit questionnaire)</li> </ul>	<ul style="list-style-type: none"> <li>• Proponent is engaging with City of Cornwall to implement a roadway damage permit (i.e. agreement to repair roads should they be deteriorated as part of the project).</li> </ul>	<ul style="list-style-type: none"> <li>• Required no alterations, amendments, or additional information.</li> </ul>
<ul style="list-style-type: none"> <li>• Concern about potential for improper decommissioning of project (also noted in Table 5.3, as comment noted on a public meeting exit questionnaire)</li> </ul>	<ul style="list-style-type: none"> <li>• Lease agreement clearly states that project owner needs to remove all equipment from site and restore the land it was in prior to condition prior to construction.</li> <li>• Renewable Energy Approval includes a commitment that project components will be removed from site at the end of the project and land restored to condition it was in prior to construction.</li> </ul>	<ul style="list-style-type: none"> <li>• Required no alterations, amendments, or additional information.</li> </ul>
<ul style="list-style-type: none"> <li>• Recycling of solar panels (also noted in Table 5.3, as comment noted on a public meeting exit questionnaire)</li> </ul>	<ul style="list-style-type: none"> <li>• Solar panels are either recycled or disposed of in a manner that conforms to all government, environmental and legal requirements.</li> <li>• The standard practice of EDF EN Canada is to negotiate a recycling/disposal provision within their solar panel supply agreements that typically includes recycling and/or</li> </ul>	<ul style="list-style-type: none"> <li>• Required no alterations, amendments, or additional information.</li> </ul>



**BARLOW SOLAR ENERGY CENTRE  
CONSULTATION REPORT**

Agency and Municipal Consultation  
June 19, 2017

**Table 6.2: Key Comments from Municipalities and Consideration by the Project Team**

Comment	Project Response	How Comments Were Considered by Project Team
	disposal and logistics (i.e., who picks up the panels, ships them where, at what cost).	

## 7.0 ABORIGINAL ENGAGEMENT

### 7.1 IDENTIFICATION OF ABORIGINAL COMMUNITIES WITH AN INTEREST IN THE PROJECT

The goal of Aboriginal consultation and engagement as it relates to the Project is to engage interested local Aboriginal communities in a way that is meaningful and respectful of their Aboriginal and treaty rights and interests in the Project area.

As per O. Reg. 359/09 S.14 (1) (b), a request was made to the Director of the MOECC on July 12, 2016 for a list of Aboriginal communities who:

- (i) *Have or may have constitutionally protected Aboriginal or treaty rights that may be adversely impacted by the project, or*
- (ii) *Otherwise may be interested in any negative environmental effects of the project.*

On August 10, 2016 (see **Table 6.1** and **Appendix C**), communication with the MOECC identified the following Aboriginal communities as having potential interest in the Project:

- Mohawks of Akwesasne
- Nation Huronne Wendat

In addition, and prior to receiving the Aboriginal community list for consultation from the MOECC, Barlow Energy Centre Limited Partnership identified the following communities as having a potential interest in the Project:

- Algonquins of Ontario
- Algonquins of Pikwàkanagàn First Nation
- Métis Nation of Ontario

Upon receiving the Aboriginal consultation list from the MOECC, the Project distribution list was updated and consultation with Aboriginal communities regarding the Project included all Aboriginal communities as identified by the MOECC.



## **7.2 COMMUNICATION ACTIVITIES**

This section describes the consultation activities undertaken so that local and interested Aboriginal communities were kept informed of Project activities and had the opportunity to provide comments, questions and interests regarding the Project. The Project distribution list for Aboriginal communities can be found in **Appendix D**. Copies of Project Meeting Notices can be found in **Appendix A**.

### **7.2.1 Notice of Proposal to Engage in a Renewable Energy Project and Notice of First Public Meeting**

The Notice of Proposal to Engage in a Renewable Energy Project and Notice of First Public Meeting, a Project Newsletter and a copy of the draft Project Description Report were couriered to the Algonquins of Ontario, the Algonquins of Pikwàkanagàn, the Métis Nation of Ontario, the Mohawk Council of Akwesasne, and Nation Huronne Wendat on August 26, 2016.

### **7.2.2 Notice of Final Public Meeting and draft REA Reports**

The Notice of Final Public Meeting was couriered to the Algonquins of Ontario, the Algonquins of Pikwàkanagàn, the Métis Nation of Ontario, the Mohawk Council of Akwesasne, and Nation Huronne Wendat on February 16, 2017.

Included with the Notice was a letter, Project newsletter # 2, the draft Project Summary Report and the Draft REA Documents. The letter requested the community provide any information they may have about any adverse impacts that the Project may have on constitutionally protected Aboriginal or treaty rights and any measures for mitigating those adverse impacts was requested.

### **7.2.3 Local Newspaper Notices**

Project meeting Notices were placed in local newspapers that serve the municipalities hosting the Project. Section 4.3 provides a summary of the local newspapers and the dates on which the Notices were published throughout the REA process.

### **7.2.4 Project Telephone, E-mail, Mail, Newsletter and Website**

A Project e-mail address, two mailing addresses and telephone numbers were published in Project meeting Notices and on the Project website as a means for interested parties and community members to provide comments, interests or submit questions regarding the Project.

The Project website and Project Notices were used to provide updates of Project activities and information, upcoming public meeting information and consultation activities. Notices, newsletters, public meeting display boards, Draft REA Reports and contact information were also made available on the Project website.

## BARLOW SOLAR ENERGY CENTRE CONSULTATION REPORT

Aboriginal Engagement  
June 19, 2017

### 7.2.5 Draft REA Reports

Section 17(1)(3) of O. Reg. 359/09 requires that a summary of the REA documents in which Aboriginal communities have expressed an interest be provided to each Aboriginal community prior to the commencement of the public review period of the Draft REA Reports. In response to this requirement, the Project Team prepared a Project Summary of the Draft REA Reports and potential environmental effects. These summaries were mailed to each Aboriginal community on February 16, 2017.

As per O. Reg. 359/09 S.16 (5) (c and d), the Draft REA Reports were sent by courier to each Aboriginal community on the Project distribution list on February 16, 2017. Copies of the report were sent to community representatives.

Each Aboriginal community was requested to provide comments or feedback on behalf of their community regarding the Draft Project Summary Report and the draft REA documents. Barlow Energy Centre Limited Partnership also extended an invitation to meet to further discuss the draft reports and the Project in greater detail.

## 7.3 OVERVIEW OF ABORIGINAL ENGAGEMENT

An overview of Aboriginal engagement activities and feedback regarding the Project is provided below and summarized in **Appendix C**.

- Mohawks of Akwesasne
- Nation Huronne Wendat
- Algonquins of Ontario
- Algonquins of Pikwàkanagàn First Nation
- Métis Nation of Ontario

### 7.3.1 Mohawks of Akwesasne

Barlow Energy Centre Limited Partnership made initial contact with the Mohawks of Akwesasne on March 28, 2016 to introduce the Project, to inform that Stage II Archaeological work was being conducted near the Project site in April 2016 offer an opportunity to monitor field work, and to offer an opportunity for the community to hold a meeting with members of the Project team. A follow-up phone call occurred on April 28, 2016 to discuss contact details. On April 29, 2016, the Project Team contacted the community asking if there was an interest to participate in Stage 2 archaeology field work.

On May 5, 2016, the community was provided with additional information about the Project, including a slide deck presentation that contained information about the Project. The community was also provided with a copy of the Site Considerations Report. An invitation to



## **BARLOW SOLAR ENERGY CENTRE CONSULTATION REPORT**

Aboriginal Engagement  
June 19, 2017

meet with the community was extended by the Project team. A follow-up email was sent by the Project team on May 9, 2016 to once again extend an offer to meet with representatives from the community to discuss the Project.

On May 16, 2016, a voice message was left with Peggy Pyke-Thompson (EA Officer/Supervisor) indicating that natural heritage studies would take place in June, and asking if anyone from the community would have an interest to participate. An offer to meet in person was again extended. A voice message was also left with Philip White-Cree (Researcher, Aboriginal Rights and Research Office) to follow up on previous materials shared about the Project and to offer an in-person follow-up meeting.

On May 27, 2016, a meeting occurred with Peggy Pyke-Thompson (Environmental Assessment Officer/Supervisor) and Henry Lickers (Environmental Science Officer). Suggestions occurred regarding vegetation planting at the site, and requests were made for MET data, to be included in natural heritage field studies, to be informed if medicinal plants are found during the natural heritage field studies, and to be included in procurement opportunities during construction.

An email in June 2016 confirmed that representatives from the Mohawks of Akwesasne would participate in a site visit to conduct natural heritage field studies on June 7, 2016. The site visit was hosted by natural heritage experts from Stantec.

An email on July 6, 2016, from Philip White-Cree confirmed that an in-person meeting was not necessary, but that his office would like to receive any archaeology reports and asked to acquire details about the Project.

As noted in Section 7.2.1, A letter introducing the Project, the Notice to Engage in a Renewable Energy Project and the draft Project Description Report, the Notice of First Public Meeting and a Project Newsletter were provided by courier to the community on August 26, 2016.

Outreach occurred in October 2016 and February 2017 to obtain feedback on the natural heritage site visit and determine opportunities for future engagement.

As noted in Section 7.2.2, on February 16, 2017 a letter, and Notice of Final Public Meeting and all draft REA reports including the draft Project Summary Report, were provided by courier. The letter requested any information about adverse impacts that the Project may have on constitutionally protected Aboriginal or treaty rights and measures to mitigate those adverse impacts. To-date, interests have been communicated to the Proponent by the Mohawks of Akwesasne including procurement, MET data, natural heritage, medicinal plants, and vegetation. Barlow Energy Centre Limited Partnership has committed to working with the Mohawks of Akwesasne to identify procurement opportunities during construction by providing an invitation to any open houses hosted by the general contractor, and has communicated that MET data will not be shared. Representatives of the Mohawks of Akwesasne participated in the natural heritage site visit, and no medicinal plants were identified. The Project Team is communicating with the Raisin Region Conservation authority regarding the appropriate species

## BARLOW SOLAR ENERGY CENTRE CONSULTATION REPORT

Aboriginal Engagement  
June 19, 2017

to vegetate the ground beneath the solar panels. A summary of correspondence with the Mohawks of Akwesasne can be found in **Appendix C** and in **Table 7.1** (see below).

### 7.3.2 Nation Huronne Wendat

As noted in Section 7.2.1, a letter introducing the Project, the Notice to Engage in a Renewable Energy Project and the draft Project Description Report, the Notice of First Public Meeting and a Project Newsletter were provided by courier to the community on August 26, 2016.

On February 3, 2017, a phone call was placed with Louis Lesage of the Nation Huronne Wendat to introduce the Project and obtain an appropriate point of contact moving forward. On February 06, 2017, a follow-up message was left with Louis Lesage on the project status, and an offer was made to meet.

As noted in Section 7.2.2., on February 16, 2017 a letter, and Notice of Final Public Meeting and all draft REA reports including the draft Project Summary Report, were provided by courier. The letter requested any information about adverse impacts that the Project may have on constitutionally protected Aboriginal or treaty rights and measures to mitigate those adverse impacts.

A voice message was left on April 19, 2017 for Maxime Picard, updating information regarding the project. A follow-up call was received on April 20, 2017 from Maxime Picard acknowledging receipt of the draft REA reports and confirming that their main interest is archaeology. A meeting occurred on May 16, 2017 with Louis Lesage, and Maxime Picard. Interests regarding archaeology and construction support were discussed.

To-date, issues or interests have been communicated by the Nation Huronne Wendat regarding archaeology and construction support. While archaeology for the project is complete and there were no findings, Barlow Energy Centre Limited Partnership will inform Nation Huronne Wendat of procurement opportunities during construction by providing an invitation to any open houses hosted by the general contractor. A summary of correspondence with the Nation Huronne Wendat can be found in **Appendix C** and in **Table 7.1** (see below).

### 7.3.3 Algonquins of Ontario

A discussion occurred with a member of an Eastern Ontario First Nation coordination working group on July 29, 2016, regarding the potential interest of the Algonquins of Ontario in the Project. Contact information was provided for the Executive Director of the Algonquins of Ontario Consultation Office.

A noted in Section 7.2.1, a letter introducing the Project, the Notice to Engage in a Renewable Energy Project and the draft Project Description Report, the Notice of First Public Meeting and a Project Newsletter were provided by courier to the community on August 26, 2016.



## BARLOW SOLAR ENERGY CENTRE CONSULTATION REPORT

Aboriginal Engagement  
June 19, 2017

A phone call occurred on November 24, 2016 with the Administrative Assistant of the Algonquins of Ontario, who indicated that the Consultation Office is aware of the project and reviewing their position. A follow up email occurred on February 2, 2017 to the Executive Director of the Algonquins of Ontario informing that they will receive draft project reports in the coming weeks and asking if any follow up meetings, in person or on the phone are preferred. No feedback has been received to date.

As noted in Section 7.2.2, on February 16, 2017 a letter, and Notice of Final Public Meeting and all draft REA reports including the draft Project Summary Report, were provided by courier. The letter requested any information about adverse impacts that the Project may have on constitutionally protected Aboriginal or treaty rights and measures to mitigate those adverse impacts.

To-date, no issues or interests have been communicated by the Algonquins of Ontario. A summary of correspondence with the Algonquins of Ontario can be found in **Appendix C**.

### 7.3.4 Algonquins of Pikwàkanagàn First Nation

Barlow Energy Centre Limited Partnership contacted the Algonquins of Pikwàkanagàn First Nation in 2015 to introduce the Project. Algonquins of Pikwàkanagàn First Nation and EDF EN Canada established a partnership for the ownership of the Project.

Since, Barlow Energy Centre Limited Partnership contacted the Algonquins of Pikwàkanagàn First Nation in March 2016 to provide a project update, to inform that Stage II Archaeological work was being conducted near the Project site in April 2016, offer monitoring, and to offer an opportunity for the community to hold a meeting with members of the Project team. The community requested a copy of the archaeology reports once they were available.

As noted in Section 7.2.1, a letter introducing the Project, the Notice to Engage in a Renewable Energy Project and the draft Project Description Report, the Notice of First Public Meeting and a Project Newsletter were provided by courier to the community on August 26, 2016.

Outreach occurred in September 2016 and February 2017 to determine opportunities for future engagement.

As noted in Section 7.2.2, on February 16, 2017 a letter, and Notice of Final Public Meeting and all draft REA reports including the draft Project Summary Report, were provided by courier. The letter requested any information about adverse impacts that the Project may have on constitutionally protected Aboriginal or treaty rights and measures to mitigate those adverse impacts.

A meeting occurred on May 10, 2017 to provide Project details to Chief and Council followed by a public meeting hosted for the community in general. A request was made for a copy of archaeology reports, to reach out to a certain individual regarding the consultation process, and to be involved in construction support.



## BARLOW SOLAR ENERGY CENTRE CONSULTATION REPORT

Aboriginal Engagement  
June 19, 2017

To-date, issues or interests have been communicated by the Algonquins of Pikwàkanagàn First Nation regarding archaeology, consultation, and construction support. Archaeology reports have been shared, and Barlow Energy Centre Limited Partnership has committed to working with the First Nation regarding on-going consultation, and to identify procurement opportunities during construction by providing an invitation to any open houses hosted by the general contractor. A summary of correspondence with the Algonquins of Pikwàkanagàn First Nation can be found in **Appendix C** and in **Table 7.1** (see below).

### 7.3.5 Métis Nation of Ontario

Stantec made initial contact with the consultation office of the Métis Nation of Ontario in April 2016 to request the names and contact information for the Métis Nation of Ontario Regional Councillor that governs the Métis Nation of Ontario territory within the Project area. The Site Consideration Report and a Project Map was also provided.

An email to the Métis Nation of Ontario Regional Councillor was sent on May 2, 2016 informing them that Stage II Archaeological work was commencing for the Project, and inviting the community to provide any relevant input into the assessments. Follow-up confirmed interest in the Project and having a meeting. In May of 2016, an email address was obtained for the Regional Councillor for Region 6. Subsequently, project information was e-mailed to that member on May 2, 2016.

Two emails have been sent to the Métis Nation of Ontario Ottawa Regional Councillor, to follow-up on the interest in the Project and for a meeting. No response has been received to-date.

Two e-mails were sent to the President of the Ottawa Region Metis Council in May of 2016, but with no response.

As noted in Section 7.2.1, a letter introducing the Project, the Notice to Engage in a Renewable Energy Project and the draft Project Description Report, the Notice of First Public Meeting and a Project Newsletter were provided by courier to the Métis Nation of Ontario on August 26, 2016.

As noted in Section 7.2.2, on February 16, 2017 a letter, and Notice of Final Public Meeting and all draft REA reports including the draft Project Summary Report, were provided by courier. The letter requested any information about adverse impacts that the Project may have on constitutionally protected Aboriginal or treaty rights and measures to mitigate those adverse impacts.

To-date, no issues or interests have been communicated by the Métis Nation of Ontario. A summary of correspondence with the Métis Nation of Ontario can be found in **Appendix C**.

**BARLOW SOLAR ENERGY CENTRE  
CONSULTATION REPORT**

Aboriginal Engagement  
June 19, 2017

**7.3.6 Summary of Key Correspondence and Consideration of Key Comments**

Correspondence and meetings have occurred with Aboriginal contacts throughout the REA process, and will continue throughout the life of the Project. A summary of the comments from Aboriginal contacts, and how the Project Team considered comments, is provided in **Table 7.1**.

Aboriginal meetings, comments, and responses from the start of the REA process in August 2016 to June 14, 2017 are summarized in **Appendix C**.

**Table 7.1: Key Comments from Aboriginal Contacts and Consideration by the Project Team**

Comment	Project Response	How Comments Were Considered by Project Team
<ul style="list-style-type: none"> <li>Have an interest to view sample job descriptions for operations and maintenance positions, and to seek opportunities for services, materials or employment during construction.</li> </ul>	<ul style="list-style-type: none"> <li>Operations and maintenance sample job descriptions shared with interested communities.</li> <li>The Project Team will send invitations to the pre-construction contractor open house events.</li> </ul>	<ul style="list-style-type: none"> <li>Required no alterations, amendments, or additional information.</li> </ul>
<ul style="list-style-type: none"> <li>Sharing of meteorological data.</li> </ul>	<ul style="list-style-type: none"> <li>Meteorological data from the site cannot be shared.</li> </ul>	<ul style="list-style-type: none"> <li>Required no alterations, amendments, or additional information.</li> </ul>
<ul style="list-style-type: none"> <li>Interest to monitor natural heritage field studies.</li> </ul>	<ul style="list-style-type: none"> <li>Mohawks of Akwesasne field monitors were present.</li> </ul>	<ul style="list-style-type: none"> <li>Required no alterations, amendments, or additional information.</li> </ul>
<ul style="list-style-type: none"> <li>Communicate finding of any medicinal plants during field studies.</li> </ul>	<ul style="list-style-type: none"> <li>No medicinal plants were found during field study works.</li> </ul>	<ul style="list-style-type: none"> <li>Required no alterations, amendments, or additional information.</li> </ul>
<ul style="list-style-type: none"> <li>Lift solar panels 13-14 feet above ground to grow crops underneath.</li> </ul>	<ul style="list-style-type: none"> <li>Likely uneconomical to lift solar panels that high above ground.</li> </ul>	<ul style="list-style-type: none"> <li>Required no alterations, amendments, or additional information.</li> </ul>
<ul style="list-style-type: none"> <li>Plant flowers beneath solar panels, for example hydro seeding wildflower mix. Perhaps eastern sweet grass good for the area (comes from seed and needs to be transplanted.)</li> </ul>	<ul style="list-style-type: none"> <li>Communicating with Raisin Region Conservation Authority regarding the appropriate species to vegetate the ground beneath the solar panels. Wildflowers and eastern sweet grass will be considered.</li> </ul>	<ul style="list-style-type: none"> <li>Required no alterations, amendments, or additional information.</li> </ul>
<ul style="list-style-type: none"> <li>Maintain a good buffer of trees around the site. Suggest eastern flowering dogwood as a good fringe species.</li> </ul>	<ul style="list-style-type: none"> <li>Communicating with Raisin Region Conservation Authority regarding the appropriate species of trees to integrate along Cornwall Centre Road. Eastern flowering dogwood will be considered.</li> </ul>	<ul style="list-style-type: none"> <li>Required no alterations, amendments, or additional information.</li> </ul>

**BARLOW SOLAR ENERGY CENTRE  
CONSULTATION REPORT**

Aboriginal Engagement  
June 19, 2017

**Table 7.1: Key Comments from Aboriginal Contacts and Consideration by the Project Team**

Comment	Project Response	How Comments Were Considered by Project Team
<ul style="list-style-type: none"> <li>When selecting trees to plant around the site, need to consider climate change and considering forest types from Boreal to Carolinian. Need to consider species like catalpa or tulip trees.</li> </ul>	<ul style="list-style-type: none"> <li>Communicating with Raisin Region Conservation Authority regarding the appropriate species of trees to integrate along Cornwall Centre Road. Eastern flowering dogwood will be considered. Catalpa trees were planted at another solar site (Pendleton Solar Energy Centre) following this feedback.</li> </ul>	<ul style="list-style-type: none"> <li>Required no alterations, amendments, or additional information.</li> </ul>
<ul style="list-style-type: none"> <li>Suggest random planting of maple sugars is best, rather than planting them all together. When the trees are about 10 years old, they can be tapped for maple sap.</li> </ul>	<ul style="list-style-type: none"> <li>Communicating with Raisin Region Conservation Authority regarding the appropriate species of trees to integrate along Cornwall Centre Road. Maple sugars will be considered. Maple trees were planted at another solar site (Pendleton Solar Energy Centre) following this feedback.</li> </ul>	<ul style="list-style-type: none"> <li>Required no alterations, amendments, or additional information.</li> </ul>
<ul style="list-style-type: none"> <li>Integrate milkweed around solar facility.</li> </ul>	<ul style="list-style-type: none"> <li>Communicating with Raisin Region Conservation Authority regarding the appropriate species of trees to integrate along Cornwall Centre Road. Integration of milkweed will be considered.</li> </ul>	<ul style="list-style-type: none"> <li>Required no alterations, amendments, or additional information.</li> </ul>
<ul style="list-style-type: none"> <li>Share archaeology reports with interested parties.</li> </ul>	<ul style="list-style-type: none"> <li>Archaeology reports shared during circulation of the draft REA reports.</li> </ul>	<ul style="list-style-type: none"> <li>Required no alterations, amendments, or additional information.</li> </ul>
<ul style="list-style-type: none"> <li>Consultation process (Algonquins of Pikwàkanagàn).</li> </ul>	<ul style="list-style-type: none"> <li>The Project Team will reach out to the appropriate contact to confirm consultation process.</li> </ul>	<ul style="list-style-type: none"> <li>Required no alterations, amendments, or additional information.</li> </ul>



# BARLOW SOLAR ENERGY CENTRE CONSULTATION REPORT

Plan for Ongoing Consultation  
June 19, 2017

## 8.0 PLAN FOR ONGOING CONSULTATION

Barlow Energy Centre Limited Partnership will continue with consultation activities following submission of the REA application to MOECC, during construction, operation and decommissioning of the Project. Barlow Energy Centre Limited Partnership has documented the communication plan for emergencies, Project updates and activities and an on-going communications and issues protocol in Section 7.0 of the Design & Operations Report.

### 8.1 FINAL REA REPORTS

Once the MOECC has deemed the REA application complete, the Proponent will place copies of the Final REA Reports on the Project website until the Director of the MOECC makes a decision under section 47.5 of the *Environmental Protection Act*.

### 8.2 COMMUNITY UPDATES

Barlow Energy Centre Limited Partnership will maintain contact with Project stakeholders (public, Aboriginal communities, and the municipalities) during the operation of the Project, as needed. Methods of communication could include providing Project updates on the Project website (<http://www.edf-en.ca/project/barlow-solar-energy-centre/>), letters, newsletters, newspaper notices, and/or direct contact via phone or email. As a long-term presence in the community, Barlow Energy Centre Limited Partnership will continue to build new contacts, local relationships and channels of communication.

Within ten (10) days of Barlow Energy Centre Limited Partnership's application for the Project being posted on the Environmental Bill of Rights (EBR) by the MOECC, the Proponent will publish a Notice in local newspapers and on the Project website (<http://www.edf-en.ca/project/Barlow-solar-energy-centre/>), providing public notice that the Project application has been accepted for review by the Ministry. The Notice will include Project information, the Project website address ([www.edf-en.ca/project/barlow-solar-energy-centre/](http://www.edf-en.ca/project/barlow-solar-energy-centre/)) where final documents can be viewed, and a statement that members of the public can submit comments to the MOECC Approvals Director via the EBR. In addition, Barlow Energy Centre Limited Partnership will provide written communication to the local Aboriginal communities informing them of the EBR posting.

### 8.3 COMMUNICATION PLAN FOR EMERGENCIES

In the event of an emergency, Barlow Energy Centre Limited Partnership and/or the Project Contractor(s) would initiate the Emergency Response Plan as outlined in Section 7.0 of the Design and Operations Report.

The Emergency Response Plan will include key contact information for emergency service providers, a description of the chain of communications and how information would be



## **BARLOW SOLAR ENERGY CENTRE CONSULTATION REPORT**

Plan for Ongoing Consultation  
June 19, 2017

disseminated between Barlow Energy Centre Limited Partnership and the relevant responders. This information will be obtained during consultations with the County, Township and City's emergency services departments. The plan would also indicate how the Barlow Energy Centre Limited Partnership and/or the Contractor would notify the community so that the appropriate actions could be taken to protect community members' health and safety. The Emergency Response Plan will be provided to the County, Township and City's emergency services departments for review and approval.

### **8.4 COMMUNICATIONS AND ISSUE RESPONSE PROTOCOL**

The following has been developed for all Project phases to address any reasonable interest from the public and would be implemented by Barlow Energy Centre Limited Partnership and/or the Project Contractor(s).

A sign will be posted during all phases of the Project at the gate of the facility which will include a telephone number, email and mailing address. The telephone number, along with the mailing and/or email address would also be posted on the Project website (<http://www.edf-en.ca/project/Barlow-solar-energy-centre/>) and provided directly to the Township, City, County and MOECC.

The telephone number provided for the reporting of questions, interests and/or complaints would be equipped with a voice message system used to record the stakeholder's name, address, telephone number, time and date, and details of the inquiry. Messages would be recorded in a Comment Response Document. Barlow Energy Centre Limited Partnership will endeavour to respond to messages within 48 hours. Reasonable efforts would be made to take appropriate action as a result of interests as soon as practicable. The actions taken and the proposed actions to be taken to prevent reoccurrences in the future (if applicable) would also be recorded. Correspondence would be shared with other stakeholders, such as the municipality or MOECC, as required and/or as deemed appropriate.

Ongoing stakeholder communication will allow Barlow Energy Centre Limited Partnership to receive and respond to general community issues on an ongoing basis.

## BARLOW SOLAR ENERGY CENTRE CONSULTATION REPORT

Closure  
June 19, 2017

### 9.0 CLOSURE

The Barlow Solar Energy Centre *Consultation Report* has been prepared by Stantec for Barlow Energy Centre Limited Partnership in accordance with Ontario Regulation 359/09, and in consideration of the *Technical Guide to Renewable Energy Approvals*.

This report has been prepared by Stantec Consulting Ltd. for the sole benefit of Barlow Energy Centre Limited Partnership, and may not be used by any third party without the express written consent of Barlow Energy Centre Limited Partnership and Stantec Consulting Ltd. The data presented in this report are in accordance with Stantec's understanding of the Project as it was presented at the time of the Report.

**APPENDIX A  
PUBLIC MEETING NOTICES, LETTERS,  
AND NEWSLETTERS**

# NOTICE OF A PROPOSAL TO ENGAGE IN A RENEWABLE ENERGY PROJECT AND NOTICE OF PUBLIC MEETING

## To be held by Barlow Energy Centre Limited Partnership regarding a Proposal to Engage in a Renewable Energy Project

**Project Name:** Barlow Solar Energy Centre (the Project)

**Project Location:** The Project is located approximately 10 km west of the City centre of Cornwall, on two parcels of privately-owned land on the north side of Cornwall Centre Road, west of Power Dam Drive. The connection line would run approximately 1 km east along Cornwall Centre Road.

**Dated at** the Township of South Stormont within the United Counties of Stormont, Dundas and Glengarry, and the City of Cornwall, on this the first of September, 2016.

Barlow Energy Centre Limited Partnership is planning to engage in a renewable energy project in respect of which the issuance of a renewable energy approval is required. The distribution of this combined Notice of a Proposal to Engage in a Renewable Energy Project and Notice of Public Meeting, and the Project itself are subject to the provisions of the Environmental Protection Act (the Act) Part V.0.1 and Ontario Regulation 359/09 (the Regulation). This Notice must be distributed in accordance with section 15 of the Regulation prior to an application being submitted and assessed for completeness by the Ministry of the Environment and Climate Change.

**Project Description:**

Pursuant to the Act and Regulation, the facility, in respect of which the project is to be engaged in, is considered to be a Class 3 Solar Facility. If approved, this facility would have a total maximum name plate capacity of 10 MW. The project location is described in the map to the right.

**Documents for Public Inspection:**

The Project is being proposed in accordance with the requirements of the Act and Regulation. The Draft Project Description Report titled Pendleton Solar Energy Centre – Draft Project Description Report describes the facility as a solar energy generating facility that will be used to convert solar energy to electricity. A written copy of the Draft Project Description Report has been made available for public inspection during regular business hours at the Township of South Stormont municipal office (2 Mille Roches Road, Long Sault) as well as the City of Cornwall municipal office (360 Pitt Street, Cornwall) and online at [www.edf-en.ca/projects/project\\_display/barlow-solar-energy-centre1](http://www.edf-en.ca/projects/project_display/barlow-solar-energy-centre1). The Draft Project Description Report will also be made available at the public meeting, described below.

**Public Meeting Information:**

A Public Meeting is being held, and stakeholder input collected, as part of the above-noted regulatory process. The meeting will provide the community with the opportunity to meet the Project team, learn more about the proposed Project and the regulatory process, and provide comments and questions regarding the Project. We would appreciate your input and welcome your attendance at our drop-in style meeting.

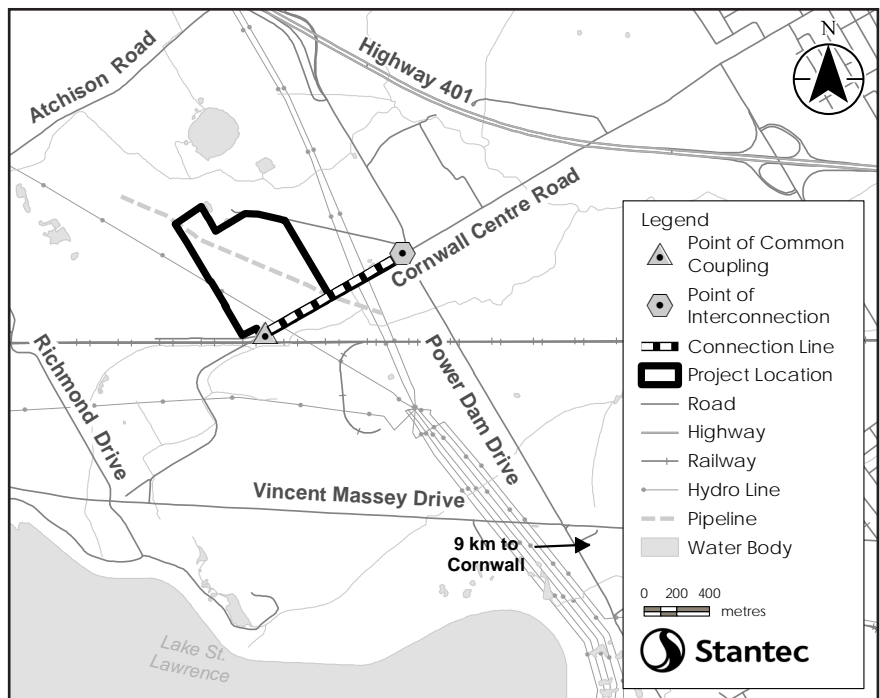

	Date	Wednesday October 5, 2016	Thursday October 6, 2016
<b>Public Meeting Locations</b>	<b>Time</b>	5:00 p.m. – 8:00 p.m.	5:00 p.m. – 8:00 p.m.
	<b>Place</b>	South Stormont Community Hall 2 Mille Roches Road, Long Sault	Best Western Parkway Inn & Conference Centre 1515 Vincent Massey Drive, Cornwall

**Project Contacts and Information:**

To learn more about the project proposal, public meeting, or to communicate concerns please refer to the contact information below.

Project Email Address: [BarlowSolar@edf-en.ca](mailto:BarlowSolar@edf-en.ca)  
 Toll-Free Phone Number: 1-844-55-EDF-EN  
 Project Website: [www.edf-en.ca/projects/project\\_display/barlow-solar-energy-centre1](http://www.edf-en.ca/projects/project_display/barlow-solar-energy-centre1)

**Fabiola Oribe**, Associate Project Developer and Stakeholder Relations  
 Pendleton Energy Centre Limited Partnership  
 53 Jarvis Street, Ste. 300, Toronto, ON M5C 2H2  
 Phone Number: 877.697.9997 (ext. 4146)

Baseball

Major League Baseball

Table with columns for American League and National League divisions: East, Central, West. Columns include W, L, Pct, GB, WCGB, L10, Str, Home, Away.

Table with columns for American League and National League divisions: East, Central, West. Columns include G, W, L, T, F, A, P.

Soccer

Major League Soccer

Table with columns for American League and National League divisions: East, Central, West. Columns include G, W, L, T, F, A, P.

Football

CFL

Table with columns for CFL divisions: East, West. Columns include G, W, L, T, F, A, P, TD, C, FG, S, Pt.

Football

CIS

Table with columns for CIS divisions: Atlantic, Quebec. Columns include G, W, L, T, F, A, P.

Baseball continuation table with columns for American League and National League divisions: East, Central, West. Columns include W, L, Pct, GB, WCGB, L10, Str, Home, Away.

Baseball continuation table with columns for American League and National League divisions: East, Central, West. Columns include G, W, L, T, F, A, P.

MLS Leaders

Table with columns for MLS leaders: GP, MINS, G, A.

Auto Racing

NASCAR Sprint Cup

Table with columns for NASCAR Sprint Cup: Through Aug. 28, STANDINGS, Points.

Tennis

U.S. Open

Table with columns for Tennis U.S. Open: Second Round, Women, Second Round.

NFL Pre-season

Table with columns for NFL Pre-season: AFC, NFC, Week Four, Wednesday's Result, Thursday's Games, Friday's Games, Monday's Games.

Golf

PGA Money Leaders

Table with columns for PGA Money Leaders: Player Name, Amount.

Today's probable pitchers

Table with columns for Today's probable pitchers: American League, National League.

Harrison, Matthews, Peppers cleared in PED inquiry

NEW YORK — NFL stars James Harrison, Clay Matthews and Julius Peppers can start the regular season without having the spectre of a league investigation over whether they used performance-enhancing drugs hanging over their heads.

The NFL cleared all three players on Wednesday, saying there was "no credible evidence" the players were guilty of any of the claims made in a documentary by Al-Jazeera America in January.

An NFL statement said "the investigation involved witness interviews, a review of relevant records and other materials, electronic research, and laboratory analysis and review."

The league threatened Harrison, Matthews, Peppers and free agent Mike Neal with indefinite suspensions if they did not meet with investigators.

All of them were mentioned in an Al-Jazeera television interview with Charlie Sly, who worked as an intern at an anti-aging clinic.

In the December report, Sly made claims of PED use by several athletes, including Harrison, Peyton Manning and the three others, but later recanted his claims.

NFLPA attorney Heather McPhee sent a letter to the NFL earlier this month of accusing it of trying to "bully and publicly shame" Harrison without offering evidence beyond a brief mention in the Al-Jazeera interview.

McPhee's letter said Harrison would meet with the NFL at 5 p.m. Aug. 30 at the team's facility, and would only discuss the portion of the Al-Jazeera interview that mentioned the 14-year veteran. The five-time Pro Bowl line-backer initially insisted NFL commissioner Roger Goodell come to Harrison's house to conduct the interview in person, though he later backed off.

"When it comes down to it I want to play," Harrison said before a nearly hour-long meeting last week.

NOTICE OF A PROPOSAL TO ENGAGE IN A RENEWABLE ENERGY PROJECT AND NOTICE OF PUBLIC MEETING

To be held by Barlow Energy Centre Limited Partnership regarding a Proposal to Engage in a Renewable Energy Project

Project Name: Barlow Solar Energy Centre (the Project)

Project Location: The Project is located approximately 10 km west of the City centre of Cornwall, on two parcels of privately-owned land on the north side of Cornwall Centre Road, west of Power Dam Drive.

Dated at the Township of South Stormont within the United Counties of Stormont, Dundas and Glengarry, and the City of Cornwall, on this the first of September, 2016.

Barlow Energy Centre Limited Partnership is planning to engage in a renewable energy project in respect of which the issuance of a renewable energy approval is required. The distribution of this combined Notice of a Proposal to Engage in a Renewable Energy Project and Notice of Public Meeting, and the Project itself are subject to the provisions of the Environmental Protection Act (the Act) Part V.0.1 and Ontario Regulation 359/09 (the Regulation).

Project Description:

Pursuant to the Act and Regulation, the facility, in respect of which the project is to be engaged in, is considered to be a Class 3 Solar Facility. If approved, this facility would have a total maximum name plate capacity of 10 MW. The project location is described in the map to the right.

Documents for Public Inspection:

The Project is being proposed in accordance with the requirements of the Act and Regulation. The Draft Project Description Report titled Pendleton Solar Energy Centre – Draft Project Description Report describes the facility as a solar energy generating facility that will be used to convert solar energy to electricity. A written copy of the Draft Project Description Report has been made available for public inspection during regular business hours at the Township of South Stormont municipal office (2 Mille Roches Road, Long Sault) as well as the City of Cornwall municipal office (360 Pitt Street, Cornwall) and online at www.edf-en.ca/projects/project\_display/barlow-solar-energy-centre1. The Draft Project Description Report will also be made available at the public meeting, described below.

Public Meeting Information:

A Public Meeting is being held, and stakeholder input collected, as part of the above-noted regulatory process. The meeting will provide the community with the opportunity to meet the Project team, learn more about the proposed Project and the regulatory process, and provide comments and questions regarding the Project. We would appreciate your input and welcome your attendance at our drop-in style meeting.

Table with columns for Public Meeting Locations: Date, Time, Place.

Project Contacts and Information:

To learn more about the project proposal, public meeting, or to communicate concerns please refer to the contact information below.

Project Email Address: BarlowSolar@edf-en.ca
Toll-Free Phone Number: 1-844-55-EDF-EN
Project Website: www.edf-en.ca/projects/project\_display/barlow-solar-energy-centre1

Fabiola Oribe, Associate Project Developer and Stakeholder Relations
Pendleton Energy Centre Limited Partnership
53 Jarvis Street, Ste. 300, Toronto, ON M5C 2H2
Phone Number: 877.697.9997 (ext. 4146)

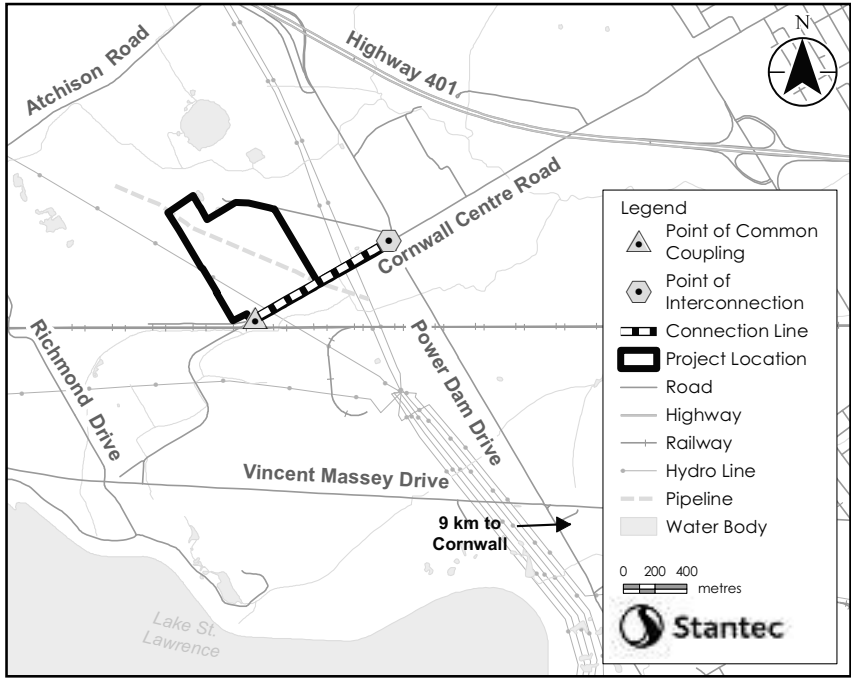

## NATIONAL NEWS

## How Liberal MPs spent their summer

Grits handed out billions during summer recess

DAVID AKIN  
NATIONAL POST

OTTAWA — MPs return to the House of Commons on Monday, officially ending their summer of spending, a summer that saw government MPs hand out cheques for almost \$8 billion for at least two tennis courts, several hockey arena renovations, two flagpoles and one gazebo.

There were also cheques for umpteen multimillion-dollar science grants, dozens of wastewater treatment plants, a handful of overseas development projects and, of course, plenty of federally funded summer festivals.

The grand total for the 94 days since the House of Commons last convened: 1,447 cheques presented by Liberal cabinet ministers and Liberal MPs worth a combined \$7.8 billion.

By comparison, the Harper Conservatives, during the 83-day long summer after their 2011 majority win, distributed 457 cheques worth a combined \$3.8 billion.

These numbers come from an exclusive database maintained by the *National Post* of every single spending announcement made by the federal government since the 2008 general election.

The gazebo in question is a new picnic shelter in Rockland, N.B., built with \$13,482 in federal funds, funds that came from a special pool of money set aside for infrastructure projects to mark next year's 150th anniversary of Canada.

That fund, known as the Canada 150 Community Infrastructure Program and worth \$150 million a year, was established by the Harper Conservatives in the 2015 budget. At the time, Liberal MPs Judy Sgro and Adam Vaughan derided it as nothing more than a pre-election "slush fund" that Conservative MPs could dip into for some easy pub-



ADRIAN WYLD/CANADIAN PRESS

The centre block of the Parliament buildings is reflected in a puddle as a woman walks past, in Ottawa. Parliament resumes Monday.

licity via cheque-handout photo opps.

But once in government, the Liberals renewed this "slush fund" for another year with another \$150 million and, over the summer, it was among the most popular envelopes of money from which Liberal MPs

drew a cheque.

Overall, 108 cheques were written to be drawn from the Canada 150 fund worth a combined \$11 million, including the one from Liberal MP T.J. Harvey, who was on hand to smile for the cameras in celebration of Rockland's new

gazebo.

And, as is the custom of every government anywhere, anytime, only government MPs and never opposition MPs get to hand out those cheques, even if the money is to be spent in an opponent's riding. So it was that, on Aug. 8, Liberal MP

Barth Chagger, who is also the government House leader, visited Rosseau, Ont., a cottage community in the heart of the riding held by Conservative Tony Clement, bearing a clutch of cheques.

It was Clement, of course, who, in 2010, had his name forever attached to the word "gazebo" in Canadian politics after the auditor general raised an eyebrow about a \$100,000 gazebo built in Orrville, Ont., but sold to Parliament as part of the infrastructure required to be host of the 2010 G8 summit held 70 kilometres away in Huntsville.

This year, Chagger had no money for gazebos but she did have plenty for other projects including dock repairs in Lake of Bays, an arena upgrade in Whitestone, and a library renovation in Huntsville. All told, Chagger had 12 cheques that day to be cashed in Clement's riding for a combined \$531,611 in federal funds.

Clement's riding, though, was just one of a tiny handful of ridings held by opposition MPs which got cheques from the Canada 150 fund this summer.

Of the 108 cheques drawn on the Canada 150 infrastructure fund, 81 worth a combined \$6 million were cashed in ridings held by Liberals. That including \$2,500 for the purchase of two flagpoles in Harley Township in the northern Ontario riding held by Liberal MP Anthony Rota. Liberals were also kind enough to distribute 14 Canada 150 cheques worth a combined \$596,100 for projects ridings held by Conservatives (almost all of that was the 12 projects in Clement's riding) while six cheques worth a combined \$343,590 went to NDP ridings.

## NOTICE OF A PROPOSAL TO ENGAGE IN A RENEWABLE ENERGY PROJECT AND NOTICE OF PUBLIC MEETING

### To be held by Barlow Energy Centre Limited Partnership regarding a Proposal to Engage in a Renewable Energy Project

**Project Name:** Barlow Solar Energy Centre (the Project)

**Project Location:** The Project is located approximately 10 km west of the City centre of Cornwall, on two parcels of privately-owned land on the north side of Cornwall Centre Road, west of Power Dam Drive. The connection line would run approximately 1 km east along Cornwall Centre Road.

**Dated at** the Township of South Stormont within the United Counties of Stormont, Dundas and Glengarry, and the City of Cornwall, on this the first of September, 2016.

Barlow Energy Centre Limited Partnership is planning to engage in a renewable energy project in respect of which the issuance of a renewable energy approval is required. The distribution of this combined Notice of a Proposal to Engage in a Renewable Energy Project and Notice of Public Meeting, and the Project itself are subject to the provisions of the Environmental Protection Act (the Act) Part V.0.1 and Ontario Regulation 359/09 (the Regulation). This Notice must be distributed in accordance with section 15 of the Regulation prior to an application being submitted and assessed for completeness by the Ministry of the Environment and Climate Change.

**Project Description:**

Pursuant to the Act and Regulation, the facility, in respect of which the project is to be engaged in, is considered to be a Class 3 Solar Facility. If approved, this facility would have a total maximum name plate capacity of 10 MW. The project location is described in the map to the right.

**Documents for Public Inspection:**

The Project is being proposed in accordance with the requirements of the Act and Regulation. The Draft Project Description Report titled Pendleton Solar Energy Centre – Draft Project Description Report describes the facility as a solar energy generating facility that will be used to convert solar energy to electricity. A written copy of the Draft Project Description Report has been made available for public inspection during regular business hours at the Township of South Stormont municipal office (2 Mille Roches Road, Long Sault) as well as the City of Cornwall municipal office (360 Pitt Street, Cornwall) and online at [www.edf-en.ca/projects/project\\_display/barlow-solar-energy-centre1](http://www.edf-en.ca/projects/project_display/barlow-solar-energy-centre1). The Draft Project Description Report will also be made available at the public meeting, described below.

**Public Meeting Information:**

A Public Meeting is being held, and stakeholder input collected, as part of the above-noted regulatory process. The meeting will provide the community with the opportunity to meet the Project team, learn more about the proposed Project and the regulatory process, and provide comments and questions regarding the Project. We would appreciate your input and welcome your attendance at our drop-in style meeting.

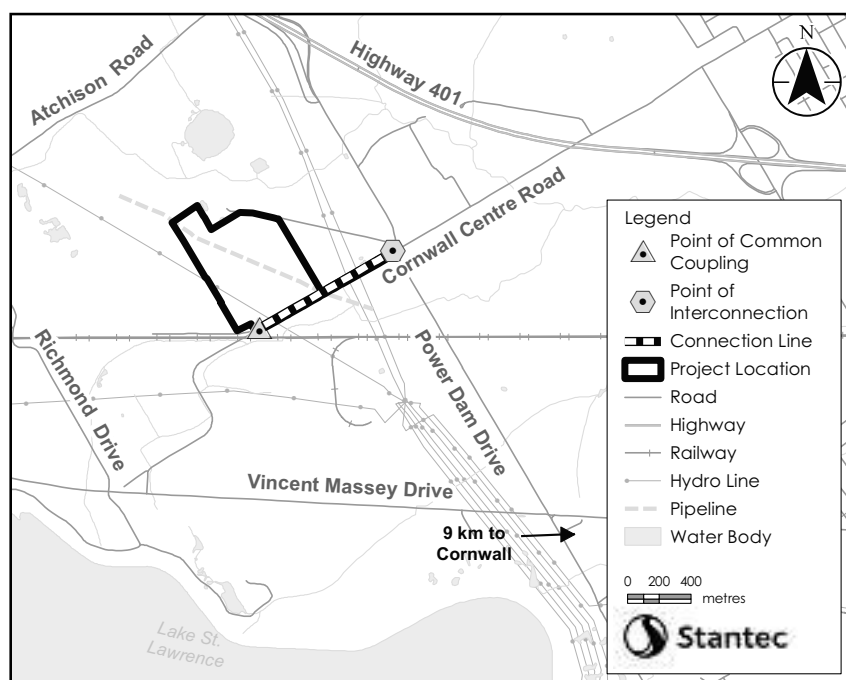

Public Meeting Locations	Date	Wednesday October 5, 2016	Thursday October 6, 2016
	Time	5:00 p.m. – 8:00 p.m.	5:00 p.m. – 8:00 p.m.
	Place	South Stormont Community Hall 2 Mille Roches Road, Long Sault	Best Western Parkway Inn & Conference Centre 1515 Vincent Massey Drive, Cornwall

**Project Contacts and Information:**

To learn more about the project proposal, public meeting, or to communicate concerns please refer to the contact information below.

Project Email Address: [BarlowSolar@edf-en.ca](mailto:BarlowSolar@edf-en.ca)  
Toll-Free Phone Number: 1-844-55-EDF-EN  
Project Website: [www.edf-en.ca/projects/project\\_display/barlow-solar-energy-centre1](http://www.edf-en.ca/projects/project_display/barlow-solar-energy-centre1)

**Fabiola Oribe**, Associate Project Developer and Stakeholder Relations  
Pendleton Energy Centre Limited Partnership  
53 Jarvis Street, Ste. 300, Toronto, ON M5C 2H2  
Phone Number: 877.697.9997 (ext. 4146)

KID'S HELP PHONE



FREE EMERGENCY CALL  
1-800-668-6868

TOLL FREE  
24 HOURS A DAY

RUNAWAY, SICK,  
IN DANGER,  
IN TROUBLE

# NOTICE OF SECOND PUBLIC MEETING

## To be held by Barlow Energy Centre Limited Partnership regarding a Proposal to Engage in a Renewable Energy Project

**Project Name:** Barlow Solar Energy Centre (the Project)

**IESO Reference Number:** L-006357-SPV-001-010

**Project Location:** The Project is located on the north side of Cornwall Centre Road, west of Power Dam Drive. The connection line would run approximately 1 km east within the road allowance of Cornwall Centre Road.

**Dated at:** the Township of South Stormont, United Counties of Stormont, Dundas and Glengarry, and the City of Cornwall, on this 22 day of February, 2017.

Barlow Energy Centre Limited Partnership is planning to engage in a renewable energy project in respect of which the issuance of a renewable energy approval (REA) is required. The proposal to engage in the Project and the Project itself are subject to the provisions of the Environmental Protection Act (the Act) Part V.0.1 and Ontario Regulation 359/09 (the Regulation). This Notice must be distributed in accordance with section 15 of the Regulation prior to an application being submitted and assessed for completeness by the Ministry of the Environment and Climate Change.

### Project Description:

Pursuant to the Act and Regulation, the facility, in respect of which the Project is to be engaged in, is considered to be a Class 3 Solar Facility that will be used to convert solar energy to electricity. If approved, this facility would have a total maximum name plate capacity of 10 MW. The Project location is shown in the map.

### Documents for Public Inspection:

Barlow Energy Centre Limited Partnership and the Project Team have prepared the following draft REA documents as part of the REA application in compliance with the requirements of the Act and Regulation:

- Project Description Report
- Construction Plan Report
- Design and Operations Report
- Decommissioning Plan Report
- Noise Study Report
- Natural Heritage Assessment and Environmental Impact Study
- Water Assessment and Water Body Report
- Stage 1 & 2 Archaeological Assessment Report
- REA Checklist: Consideration of Potential for Heritage Resources
- Project Summary Report

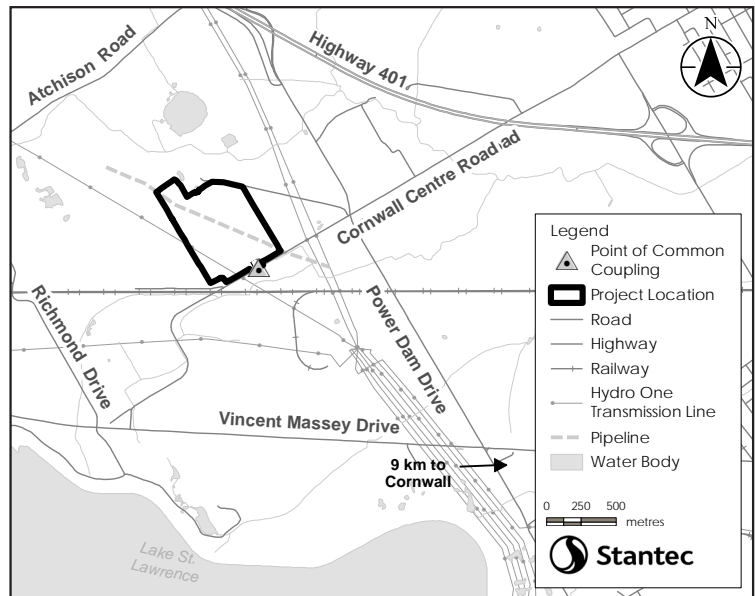

Draft copies of the above REA documents are available for public inspection online at the Project website ([www.edf-en.ca/project/barlow-solar-energy-centre](http://www.edf-en.ca/project/barlow-solar-energy-centre)) and during regular business hours at the following locations, as of February 22, 2017:

Township of South Stormont Municipal Office  
2 Mille Roches Road  
Long Sault, Ontario

City of Cornwall Municipal Office  
360 Pitt Street  
Cornwall, Ontario

Draft copies of the above REA documents will also be made available at the public meetings described below.

### Public Meeting Locations:

Barlow Energy Centre Limited Partnership is hosting a second round of Public Meetings to give stakeholders an opportunity to provide input on the draft reports, speak with the Project team, learn more about the proposed Project, and provide comments and questions regarding the draft REA documents and the Project. We would appreciate your input and welcome your attendance at our drop-in style public meetings.

Date	Monday, April 24, 2017	Tuesday April 25, 2017
Time	4:00 p.m. – 7:00 p.m.	4:00 p.m. – 7:00 p.m.
Location	Best Western Parkway Inn & Conference Centre 1515 Vincent Massey Drive Cornwall, Ontario	South Stormont Community Hall 2 Mille Roches Road Long Sault, Ontario

### Project Contacts and Information:

To learn more about the Project, public meetings, or to communicate concerns please contact:

Project Email Address: [BarlowSolar@edf-en.ca](mailto:BarlowSolar@edf-en.ca)

Toll-Free Phone Number: 1-844-55-EDF-EN

Project Website: [www.edf-en.ca/project/barlow-solar-energy-centre](http://www.edf-en.ca/project/barlow-solar-energy-centre)

**Fabiola Oribe**, Associate Project Developer and Stakeholder Relations  
Pendleton Energy Centre Limited Partnership  
53 Jarvis Street, Ste. 300, Toronto, ON M5C 2H2  
Phone Number: 877.697.9997 (ext. 4146)





BEN CURTIS/AP PHOTOS

A student looks up at the moon through a telescope, during a visit by The Traveling Telescope to show students the science of astronomy earlier this month at St Andrew's School near Molo in Kenya's Rift Valley. Below: Astronomer and company co-founder Daniel Chu Owen sets up the telescope.

# Roaming telescope brightens night for Kenyan children

MOLO, Kenya – Thousands of schoolchildren in Kenya are getting a rare opportunity to look at the stars.

The Traveling Telescope visits some of this East African country's most remote areas, showing students the night sky and the describing the science of astronomy with telescopes and virtual reality goggles.

One by one, the children in this Rift Valley town lined up to peer through the telescope.

Fourteen-year-old Evie Clarke gazed into the sky.

"Over there is Venus and just

above it is Mars and there are loads of suns," she said, pointing. "You have such a nice picture of the moon and you can see all the craters. Oh man, it was amazing, yes!"

Students also enter an inflatable planetarium to learn more about astronomy, and they look at constellations using virtual reality goggles.

Although Kenya lies on the equator and has dramatic night-time skies in rural areas, children find it hard to name planets and other bodies as astronomy is rarely taught in schools.

The telescope "has been around for more than 400 years and yet very few people have looked through one," said Susan Murabana, who founded the Traveling Telescope project in 2013 with Daniel Chu Owen. They charge 200 to 300 Kenyan shillings, or about \$2 to \$3, per child at international or private schools. They do not charge at public schools.

They would like to expand the project across Africa "There is something really powerful about seeing things for yourself and seeing those photons coming from a star or planet or what-



ever is going through the telescope hitting your eye, you know," Owen said. "You are not looking at a screen, you are not looking in a book ... It stays with you."

Fifteen-year-old Tamara Lugonzo said she is considering a career in astronomy after her experience: "It's so cool, yeah!" — *The Associated Press*

**Public Notices**   **Public Notices**   **Public Notices**   **Public Notices**   **Public Notices**   **Public Notices**   **Public Notices**

## NOTICE OF SECOND PUBLIC MEETING

**To be held by Barlow Energy Centre Limited Partnership regarding a Proposal to Engage in a Renewable Energy Project**

**Project Name:** Barlow Solar Energy Centre (the Project)  
**IESO Reference Number:** L-006357-SPV-001-010

**Project Location:** The Project is located on the north side of Cornwall Centre Road, west of Power Dam Drive. The connection line would run approximately 1 km east within the road allowance of Cornwall Centre Road.

**Dated at:** the Township of South Stormont, United Counties of Stormont, Dundas and Glengarry, and the City of Cornwall, on this 22 day of February, 2017.

Barlow Energy Centre Limited Partnership is planning to engage in a renewable energy project in respect of which the issuance of a renewable energy approval (REA) is required. The proposal to engage in the Project and the Project itself are subject to the provisions of the Environmental Protection Act (the Act) Part V.0.1 and Ontario Regulation 359/09 (the Regulation). This Notice must be distributed in accordance with section 15 of the Regulation prior to an application being submitted and assessed for completeness by the Ministry of the Environment and Climate Change.

**Project Description:**  
 Pursuant to the Act and Regulation, the facility, in respect of which the Project is to be engaged in, is considered to be a Class 3 Solar Facility that will be used to convert solar energy to electricity. If approved, this facility would have a total maximum name plate capacity of 10 MW. The Project location is shown in the map.

**Documents for Public Inspection:**  
 Barlow Energy Centre Limited Partnership and the Project Team have prepared the following draft REA documents as part of the REA application in compliance with the requirements of the Act and Regulation:

- Project Description Report
- Construction Plan Report
- Design and Operations Report
- Decommissioning Plan Report
- Noise Study Report
- Natural Heritage Assessment and Environmental Impact Study
- Water Assessment and Water Body Report
- Stage 1 & 2 Archaeological Assessment Report
- REA Checklist: Consideration of Potential for Heritage Resources
- Project Summary Report

Draft copies of the above REA documents are available for public inspection online at the Project website ([www.edf-en.ca/project/barlow-solar-energy-centre](http://www.edf-en.ca/project/barlow-solar-energy-centre)) and during regular business hours at the following locations, as of February 22, 2017:

Township of South Stormont Municipal Office 2 Mille Roches Road Long Sault, Ontario	City of Cornwall Municipal Office 360 Pitt Street Cornwall, Ontario
---	---

Draft copies of the above REA documents will also be made available at the public meetings described below.

**Public Meeting Locations:**  
 Barlow Energy Centre Limited Partnership is hosting a second round of Public Meetings to give stakeholders an opportunity to provide input on the draft reports, speak with the Project team, learn more about the proposed Project, and provide comments and questions regarding the draft REA documents and the Project. We would appreciate your input and welcome your attendance at our drop-in style public meetings.

Date	Monday, April 24, 2017	Tuesday April 25, 2017
<b>Time</b>	4:00 p.m. – 7:00 p.m.	4:00 p.m. – 7:00 p.m.
<b>Location</b>	Best Western Parkway Inn & Conference Centre 1515 Vincent Massey Drive Cornwall, Ontario	South Stormont Community Hall 2 Mille Roches Road Long Sault, Ontario

**Project Contacts and Information:**  
 To learn more about the Project, public meetings, or to communicate concerns please contact:  
 Project Email Address: [BarlowSolar@edf-en.ca](mailto:BarlowSolar@edf-en.ca)  
 Toll-Free Phone Number: 1-844-55-EDF-EN  
 Project Website: [www.edf-en.ca/project/barlow-solar-energy-centre](http://www.edf-en.ca/project/barlow-solar-energy-centre)

**Fabiola Orbe**, Associate Project Developer and Stakeholder Relations  
 Pendleton Energy Centre Limited Partnership  
 53 Jarvis Street, Ste. 300, Toronto, ON M5C 2H2  
 Phone Number: 877.697.9997 (ext. 4146)

Get Ready, Get Set...  
*Celebrate*

**DO YOU HAVE A SIGNIFICANT MILESTONE OR ANNIVERSARY?**

Many sizes to choose from:

2x40	3.31" x 2.86"
2x80	3.31" x 5.71"
4x40	4.56" x 2.86"
4x80	4.56" X 5.71"

*Birthday, Stag and Doe, Wedding Reception, Retirement?*

**WE CAN HELP YOU Celebrate!**  
 print & online

**613-933-3160** ext. 508237  
[brenda.primeau@sunmedia.ca](mailto:brenda.primeau@sunmedia.ca)

**STANDARD FREEHOLDER**

## CALL 613-933-3160 TO ADVERTISE IN OUR DIRECTORY

# SALES & SERVICE DIRECTORY

<p><b>Business Consulting Services</b></p> <p><b>"Eliminate Your Excessive Debt"</b></p> <p>One affordable monthly payment, <b>NO</b> Interest</p> <p><b>FREE CONSULTATION</b></p> <p>Contact: <b>Dean Hustins</b>                  Director,                  Personal Insolvency Services</p> <p><b>Doyle Salewski Inc.</b></p> <p>Cornwall Office:                  36 Second St. E.                  Head Office 396 Bank St., Ottawa</p> <p><b>613-932-7827</b>  <b>1-800-517-9926</b>  <a href="http://www.doylesalewski.ca">www.doylesalewski.ca</a></p> <p><small>CREDIT COUNSELLORS &amp; TRUSTEE • BANKRUPTCY</small></p>	<p><b>Home Improvement</b></p> <p><b>PRISTINE</b>                  TILE &amp; GROUT RESTORATION</p> <p><b>DON'T REPLACE YOUR OLD TILE &amp; GROUT</b></p> <p><b>FREE ESTIMATE</b></p> <p>Contact: Cory Smith                  613-769-5251                  Email: <a href="mailto:groutsmith613@gmail.com">groutsmith613@gmail.com</a></p>	<p><b>General Services</b></p> <p><b>LEGER'S TREASURES</b></p> <p><b>Buys Household Goods</b></p> <p><b>(ESTATES)</b></p> <p><b>613-937-0166</b></p>	<p><b>Painters &amp; Decorators</b></p> <p><b>André The Painter</b></p> <p>Serving Cornwall and Surrounding area for over 25 years</p> <p><b>Residential &amp; Commercial Interior / Exterior</b></p> <p><b>LIMITED TIME OFFER!</b></p> <p><b>Up to 25% off</b></p> <p><b>"The Real M<sup>c</sup>Coy"</b>  <b>613-936-2989</b></p>	<p><b>Tree Services</b></p> <p><b>TREE SERVICE</b></p> <p><b>Woodsman Construction &amp; Tree Service</b></p> <p>Tree Removal - Trimming - Pruning - Brush Chipping - Stump Grinding - Lot Clearing                  Water &amp; Sewer line Repairs / Replacement                  Ontario Certified Arborist</p> <p>Free Estimates Fully Insured</p> <p><b>613-933-2091</b>                  After hours: <b>613-551-9084</b></p>
---	---	--	--	--

## CALL 613-933-3160 TO ADVERTISE IN OUR DIRECTORY. WE HAVE THE SPACE AND DEAL TO FIT YOUR NEEDS!

# Trio of losses for Nationals

Record is better at home than when travelling

KEVIN GOULD  
STANDARD-FREEHOLDER

The road has not been kind to the Cornwall Nationals. Not that the civic complex has been overly generous either, the Nats holding a rather pedestrian home record of 8-8 following a 4-2 loss to the Watertown Wolves on Sunday afternoon, in front of 680 fans. Still, the home mark is positively glowing when compared to

Cornwall's road work, where they have just five wins, with 18 dents in the loss column. That record includes a pair of weekend losses ahead of Sunday's tilt at the civic complex — 4-3 at Berlin on Friday, and 5-1 in Watertown on Saturday. "We're a different team on the road, for sure," said Joel Trottier following Sunday's contest. "Some guys have a tough time making the road games. "Most teams aren't like that — it's the same team all the time." Most teams though, house players. The Nationals do not, at least not in this, their inaugural FHL

season. So, you play with the hand that's dealt you, and Cornwall's is a little beat up at the moment. "We're banged up a bit, but we have to find a way," said Trottier, the player/coach with the Nats, who was coach only on this day, a groin injury keeping him out of the lineup. He was on the bench with Basem Awwad, who took over from Alain Quenneville a couple of weeks ago. Overall the Nats are 11-23-3-2, in sixth place in the FHL, ahead of (barely) only the St. Clair Shores Fighting Saints, and 17 points out of the fourth and final playoff spot. "It's down to the nitty gritty here," said Trottier.

Quite a deficit to make up. "It is, but in this league, with the three points for a win, it's not as bad — five wins, 15 points, you're right back in it. And the good thing is, we play the teams we're trying to catch the rest of the way, for the most part. "And, we'll play right to the end, I can tell you that." They did on Sunday, but never could pull even in the third period, after earlier erasing a two-goal deficit. "We had our chances though," lamented Trottier. "Three breakaways in the third period alone. Just couldn't bury anything."

Watertown jumped in front by a pair in the opening period, getting goals from former National Jason Dolgy and Long Sault native Brett Liscomb. The Nats cut the lead in half just before the end of the first frame, Darick Ste Marie connecting with 13.2 ticks left on the clock. Cornwall tied it with 3:50 left in the second, Storm Adams of Akwesasne scoring his fifth goal (and ninth point) in six games with the Nats. When you're hot, you're hot, as Adams' centring pass from behind the net hit a Watertown defender and scooted under Wolves' netminder Danila Alistratov.

## CLASSIFIEDS

Phone: 1-888-786-7821 • Fax: 1-866-757-0227 • Email: standard-freeholder.classifieds@sunmedia.ca

standard-freeholder.com/classifieds

General Help Wanted    General Help Wanted    General Help Wanted    Public Notices    Public Notices    Public Notices    Public Notices    Public Notices    Public Notices    Public Notices

### Come Work With Us!



#### CARRIERS & SUBSTITUTE CARRIERS WANTED

Early morning delivery, 6 days/week. Routes available in:

- CORNWALL East ~ Central ~ West
- AVONMORE ~ LONG SAULT INGLESIDE
- ALEXANDRIA

**FOR DETAILS CALL TODAY!**  
1-800-267-9837 or 613-933-3160  
Ext. 508293 or 508258  
or Email: [bmacdonald@postmedia.com](mailto:bmacdonald@postmedia.com)  
[cterriah@postmedia.com](mailto:cterriah@postmedia.com)



### NOTICE OF SECOND PUBLIC MEETING

To be held by Barlow Energy Centre Limited Partnership regarding a Proposal to Engage in a Renewable Energy Project

**Project Name:** Barlow Solar Energy Centre (the Project)  
**IESO Reference Number:** L-006357-SPV-001-010

**Project Location:** The Project is located on the north side of Cornwall Centre Road, west of Power Dam Drive. The connection line would run approximately 1 km east within the road allowance of Cornwall Centre Road.

**Dated at:** the Township of South Stormont, United Counties of Stormont, Dundas and Glengarry, and the City of Cornwall, on this 22 day of February, 2017.

Barlow Energy Centre Limited Partnership is planning to engage in a renewable energy project in respect of which the issuance of a renewable energy approval (REA) is required. The proposal to engage in the Project and the Project itself are subject to the provisions of the Environmental Protection Act (the Act) Part V.0.1 and Ontario Regulation 359/09 (the Regulation). This Notice must be distributed in accordance with section 15 of the Regulation prior to an application being submitted and assessed for completeness by the Ministry of the Environment and Climate Change.

**Project Description:** Pursuant to the Act and Regulation, the facility, in respect of which the Project is to be engaged in, is considered to be a Class 3 Solar Facility that will be used to convert solar energy to electricity. If approved, this facility would have a total maximum name plate capacity of 10 MW. The Project location is shown in the map.

**Documents for Public Inspection:** Barlow Energy Centre Limited Partnership and the Project Team have prepared the following draft REA documents as part of the REA application in compliance with the requirements of the Act and Regulation:

- Project Description Report
- Construction Plan Report
- Design and Operations Report
- Decommissioning Plan Report
- Noise Study Report
- Natural Heritage Assessment and Environmental Impact Study
- Water Assessment and Water Body Report
- Stage 1 & 2 Archaeological Assessment Report
- REA Checklist: Consideration of Potential for Heritage Resources
- Project Summary Report

Draft copies of the above REA documents are available for public inspection online at the Project website ([www.edf-en.ca/project/barlow-solar-energy-centre](http://www.edf-en.ca/project/barlow-solar-energy-centre)) and during regular business hours at the following locations, as of February 22, 2017:

Township of South Stormont Municipal Office 2 Mille Roches Road Long Sault, Ontario	City of Cornwall Municipal Office 360 Pitt Street Cornwall, Ontario
---	---

Draft copies of the above REA documents will also be made available at the public meetings described below.

**Public Meeting Locations:** Barlow Energy Centre Limited Partnership is hosting a second round of Public Meetings to give stakeholders an opportunity to provide input on the draft reports, speak with the Project team, learn more about the proposed Project, and provide comments and questions regarding the draft REA documents and the Project. We would appreciate your input and welcome your attendance at our drop-in style public meetings.

Date	Monday, April 24, 2017	Tuesday April 25, 2017
<b>Time</b>	4:00 p.m. – 7:00 p.m.	4:00 p.m. – 7:00 p.m.
<b>Location</b>	Best Western Parkway Inn & Conference Centre 1515 Vincent Massey Drive Cornwall, Ontario	South Stormont Community Hall 2 Mille Roches Road Long Sault, Ontario

**Project Contacts and Information:**  
To learn more about the Project, public meetings, or to communicate concerns please contact:  
Project Email Address: [BarlowSolar@edf-en.ca](mailto:BarlowSolar@edf-en.ca)  
Toll-Free Phone Number: 1-844-55-EDF-EN  
Project Website: [www.edf-en.ca/project/barlow-solar-energy-centre](http://www.edf-en.ca/project/barlow-solar-energy-centre)  
**Fabiola Orbe**, Associate Project Developer and Stakeholder Relations  
Pendleton Energy Centre Limited Partnership  
53 Jarvis Street, Ste. 300, Toronto, ON M5C 2H2  
Phone Number: 877.697.9997 (ext. 4146)

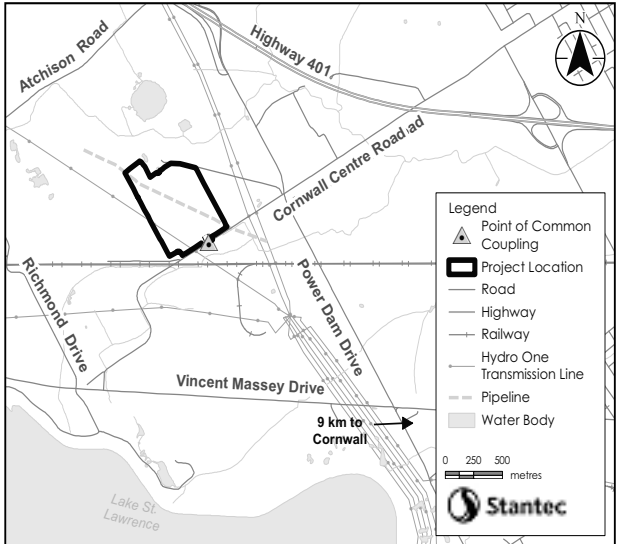

### COME WORK WITH US!



#### SUBSTITUTES WANTED

Early morning delivery, 6 days/week. for the following areas:  
CORNWALL - AVONMORE - LONG SAULT - INGLESIDE - ALEXANDRIA

**Requirements: Knowledge of City, Car and Cell Phone**

**FOR DETAILS CALL TODAY!**  
1-800-267-9837 or 613-933-3160  
Ext. 508293 or 508258  
or Email: [bmacdonald@postmedia.com](mailto:bmacdonald@postmedia.com)  
[cterriah@postmedia.com](mailto:cterriah@postmedia.com)



## businessdirectory

<b>Business Consulting Services</b> "Eliminate Your Excessive Debt" One affordable monthly payment, NO Interest <b>FREE CONSULTATION</b> Contact: <b>Dean Hustins</b> Director, Personal Insolvency Services <b>613-932-7827</b> 1-800-517-9926 Cornwall Office: 36 Second St. E. Head Office 396 Bank St., Ottawa <a href="http://www.doylesalewski.ca">www.doylesalewski.ca</a> CREDIT COUNSELLORS & TRUSTEE *BANKRUPTCY	<b>Painters &amp; Decorators</b> <b>André The Painter</b> Serving Cornwall and Surrounding area for over 25 years Residential & Commercial Interior / Exterior <b>LIMITED TIME OFFER!</b> Up to <b>25% off</b> "The Real M <sup>c</sup> Coy" <b>613-936-2989</b>	<b>Antique Refinishing /Upholstery</b> <b>BELMONTE UPHOLSTERY</b> <b>FEBRUARY SPECIAL</b> <b>50% OFF &amp; Labour</b> 10% DISCOUNT FOR SENIORS Commercial, Residential & Boats Specializing in Antiques Free Estimates & Delivery Work Guaranteed • 50 Years Experience <b>613-937-3214</b> <b>613-330-8484</b>
<b>Home Improvement</b> <b>PRISTINE TILE &amp; GROUT RESTORATION</b> <b>DON'T REPLACE YOUR OLD TILE &amp; GROUT</b> <b>FREE ESTIMATE</b> Contact: Cory Smith 613-769-5251 Email: <a href="mailto:groutsmith613@gmail.com">groutsmith613@gmail.com</a>	<b>Roofing</b> <b>Done Right Roofing</b> "GET THE JOB DONE RIGHT!" RESIDENTIAL & COMMERCIAL ROOFING SPECIALISTS • SHINGLES & FLAT ROOFS • 25 YEAR WARRANTY • RE-ROOFS • 2 PLY MEMBRANE ROOFING • NEW ROOFS • REPAIR FREE EST. WATES & REFERENCES FULLY INSURED CALL (613) 933-2157	<b>Florists</b> <b>FLEURISTE ROY FLORIST</b> LATE ORDERS WELCOMED We deliver and carry numerous gift items. <b>613-933-2214</b> <a href="http://www.facebook.com/roysflorist">www.facebook.com/roysflorist</a>
<b>General Services</b> <b>LEGER'S TREASURES Buys Household Goods (ESTATES)</b> <b>613-937-0166</b>	<b>Tree Services</b> <b>TREE SERVICE</b> <b>Woodman Construction &amp; Tree Service</b> Tree Removal - Trimming - Pruning - Brush Chipping - Stump Grinding - Lot Clearing Water & Sewer line Repairs / Replacement Ontario Certified Arborist Free Estimates Fully Insured <b>613-933-2091</b> After hours: <b>613-551-9084</b>	<b>Find It Here!</b> <b>FIND IT HERE!</b>

### Antiques & Art Collectibles

**Apartment**

**1 BDRM upper fl** \$675 heated, 1113 2nd St W  
**613 363 6838**  
**BACH ground fl** \$565 util incl, 1121 Capt Macdonald,  
**2 BDRM** upstairs, \$825 util incl 221 7th St W  
**3 BDRM** main floor, **3 BDRM** upstairs \$825 heated, 525/529 14th St W,  
**613 363 7181**  
**2 BDRM** upstairs \$850 util incl 424 2nd St E  
**613 363 6555**  
Yr lease, Ref F/L req

**SELL YOUR STUFF HERE!**



**YOUR AD HERE**

Go to: [standard-freeholder.com/classifieds](http://standard-freeholder.com/classifieds)

Online only and print/online combos available!  
Save \$\$\$ placing an ad yourself!

FIND STUFF HERE!

# NATIONAL NEWS

## Assad must be 'held to account': PM

Russia partly to blame for Syria attack; country's future can't include Assad: Trudeau

LEE BERTHIAUME  
THE CANADIAN PRESS

COURSEULLES-SUR-MER, France — Bashar Assad's days as president of Syria are numbered, Prime Minister Justin Trudeau suggested Monday as more tough talk from the United States brought the threat of escalating conflict in the Middle East into even sharper relief.

The way forward in Syria can't include Assad, whose recent chemical attack against his own people were abetted by those countries — Russia and Iran — that have allowed him to remain in power, Trudeau told a news conference.

"There is no question that anyone who is guilty of the types of war crimes against innocents, against children, that Assad and his regime are needs to be held to account," he said during a visit to Juno Beach to commemorate Canada's Second World War dead.

"We need to move as quickly as possible towards peace and stability in Syria that does not involve Bashar al-Assad."

Trudeau was, however, non-committal when it came to the question of how to remove Assad from power, and whether Russia should be punished for supporting him. Canada remains open to imposing new sanctions against Russia in concert with its allies, he said, but Russia must also be part of the solution for bringing peace to Syria.

"Countries that have been supportive of the Assad regime bear some of the responsibility for the chemical attacks on innocents," he said.

"And those countries must also be part of the solution as we hold the Assad regime to account and as we move tangibly forward as an international community to ending this conflict in Syria."

The U.S. fired 59 cruise missiles at a Syrian airfield last week in retaliation for the chemical attack, sparking tough talk and warnings from all sides.

On Monday, the tension was only mounting.

The degree of hostility intensified on multiple fronts between the U.S. and its allies, versus

Assad and his backers Iran and Russia. The U.S. said it has evidence Russia's military helped cover up the use of chemical weapons.

And the U.S. threatened to strike Assad again, even expanding its possible justifications for future strikes.

Three times during Monday's White House briefing, Trump spokesman Sean Spicer mentioned barrel bombs as another reason for launching attacks on Assad.

"I will tell you: ... if you gas a baby, if you put a barrel bomb into innocent people, I think you will see a response from this president," Spicer said, although he later elaborated, saying he was referring to barrels containing chlorine.

That came on the same day the administration suggested Russia broke an international deal to gather Assad's chemical weapons. In fact, an administration official was cited telling the Associated Press that it actually helped Syria cover up its use of the illegal weapon.

The AP reported that the official said a Russian-operated drone flew over a hospital in Syria as victims of the attack

were rushing to get treatment; then, hours later, a Russian-made fighter jet bombed the hospital in what American officials believe was a coverup effort.

Meanwhile, Assad's allies reportedly threatened retaliation if the U.S. strikes again.

That threat reportedly came Monday from a coalition of Assad military backers including Russia and Iran. Various news reports said that coalition released a statement with a warning: "From now on we will respond to anyone, including America if it attacks Syria and crosses the red lines."

The statement reportedly said: "America knows very well our ability and capabilities to respond well to them."

The U.S. is hinting that its true long-term purpose in striking the airfield was to send a political message — that long-term peace in Syria will require changes in government, and the countries backing Assad should stop keeping him in place.

Yet the U.S. has sent mixed messages about what it wants in the short term; it's not even clear whether Washington intends to help oust Assad.

The Trump administration says that ambiguity is intentional. One government official after another has suggested they would like to see Assad gone, but not elaborated on whether it's an immediate U.S. priority.

Trump's spokesman says that lack of clarity is no accident.

"He's going to keep his cards close to the vest," Spicer said of Trump. "But make no mistake: he will act."

Trudeau was in France for two days of overseas commemorations for Canadian soldiers killed in the two world wars, including the 100th anniversary of the Battle of Vimy Ridge and Canada's role in D-Day on June 6, 1944.

"The men who fought in 1944 were carrying the legacy of those who risked their lives at Vimy Ridge in 1917," Trudeau said after walking the beach with his wife Sophie Gregoire Trudeau and their son Xavier.

But there was no escaping the here and now, with the attack in Syria still fresh on everyone's mind. And the irony wasn't lost on Trudeau.

The prime minister left no doubt that he considered Assad's government responsible for last week's chemical attack, which



ARIAN WYLD/THE CANADIAN PRESS

Prime Minister Justin Trudeau, left, Sophie Gregoire-Trudeau, right, and their son Xavier visit Juno Beach Monday in Courseulles-sur-Mer, France.

### NOTICE OF SECOND PUBLIC MEETING

#### To be held by Barlow Energy Centre Limited Partnership regarding a Proposal to Engage in a Renewable Energy Project

**Project Name:** Barlow Solar Energy Centre (the Project)

**IESO Reference Number:** L-006357-SPV-001-010

**Project Location:** The Project is located on the north side of Cornwall Centre Road, west of Power Dam Drive. The connection line would run approximately 1 km east within the road allowance of Cornwall Centre Road.

**Dated at:** the Township of South Stormont, United Counties of Stormont, Dundas and Glengarry, and the City of Cornwall, on this 22 day of February, 2017.

Barlow Energy Centre Limited Partnership is planning to engage in a renewable energy project in respect of which the issuance of a renewable energy approval (REA) is required. The proposal to engage in the Project and the Project itself are subject to the provisions of the Environmental Protection Act (the Act) Part V.0.1 and Ontario Regulation 359/09 (the Regulation). This Notice must be distributed in accordance with section 15 of the Regulation prior to an application being submitted and assessed for completeness by the Ministry of the Environment and Climate Change.

**Project Description:** Pursuant to the Act and Regulation, the facility, in respect of which the Project is to be engaged in, is considered to be a Class 3 Solar Facility that will be used to convert solar energy to electricity. If approved, this facility would have a total maximum name plate capacity of 10 MW. The Project location is shown in the map.

**Documents for Public Inspection:** Barlow Energy Centre Limited Partnership and the Project Team have prepared the following draft REA documents as part of the REA application in compliance with the requirements of the Act and Regulation:

- Project Description Report
- Construction Plan Report
- Design and Operations Report
- Decommissioning Plan Report
- Noise Study Report
- Natural Heritage Assessment and Environmental Impact Study
- Water Assessment and Water Body Report
- Stage 1 & 2 Archaeological Assessment Report
- REA Checklist: Consideration of Potential for Heritage Resources
- Project Summary Report

Draft copies of the above REA documents are available for public inspection online at the Project website ([www.edf-en.ca/project/barlow-solar-energy-centre](http://www.edf-en.ca/project/barlow-solar-energy-centre)) and during regular business hours at the following locations, as of February 22, 2017:

Township of South Stormont Municipal Office 2 Mille Roches Road Long Sault, Ontario	City of Cornwall Municipal Office 360 Pitt Street Cornwall, Ontario
---	---

Draft copies of the above REA documents will also be made available at the public meetings described below.

**Public Meeting Locations:**

Barlow Energy Centre Limited Partnership is hosting a second round of Public Meetings to give stakeholders an opportunity to provide input on the draft reports, speak with the Project team, learn more about the proposed Project, and provide comments and questions regarding the draft REA documents and the Project. We would appreciate your input and welcome your attendance at our drop-in style public meetings.

Date	Monday, April 24, 2017	Tuesday April 25, 2017
<b>Time</b>	4:00 p.m. – 7:00 p.m.	4:00 p.m. – 7:00 p.m.
<b>Location</b>	Best Western Parkway Inn & Conference Centre 1515 Vincent Massey Drive Cornwall, Ontario	South Stormont Community Hall 2 Mille Roches Road Long Sault, Ontario

**Project Contacts and Information:**

To learn more about the Project, public meetings, or to communicate concerns please contact:

Project Email Address: [BarlowSolar@edf-en.ca](mailto:BarlowSolar@edf-en.ca)  
Toll-Free Phone Number: 1-844-55-EDF-EN  
Project Website: [www.edf-en.ca/project/barlow-solar-energy-centre](http://www.edf-en.ca/project/barlow-solar-energy-centre)

**Fabiola Oribe**, Associate Project Developer and Stakeholder Relations  
Pendleton Energy Centre Limited Partnership  
53 Jarvis Street, Ste. 300, Toronto, ON M5C 2H2  
Phone Number: 877.697.9997 (ext. 4146)

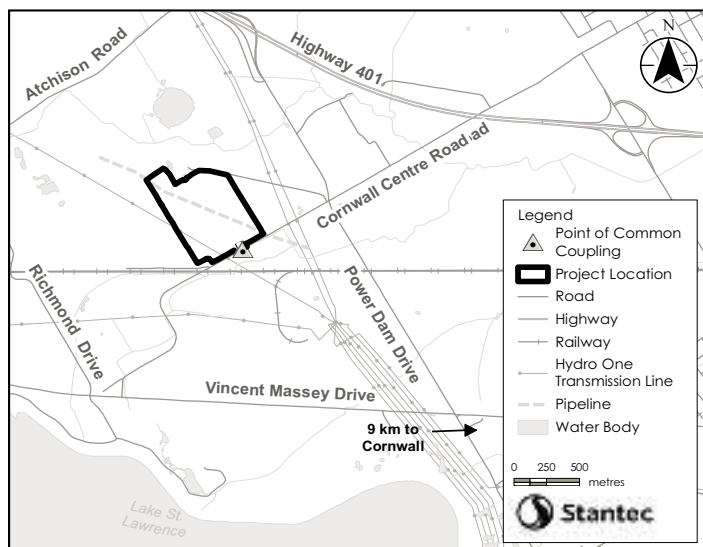

**DIVERDALE TERRACE**  
Waterfront Retirement Residence

**CALL TRACY JONES TODAY TO BOOK YOUR PERSONAL TOUR**

**613-932-3707**  
1200 Second Street W, Cornwall ON

Locally Owned and Operated [www.riverdaleterrace.ca](http://www.riverdaleterrace.ca)

*Carefree Luxury Living*

**KNOX CITY CENTRE**

**Luxurious Apartments for Rent**

**2 Bedroom with Balcony Available, 4 Stainless Steel Kitchen Appliances. Supplied in-suite Laundry equipment.**

See info at [www.knoxcitycentre.ca](http://www.knoxcitycentre.ca)

Please call for an appointment  
**613-534-8400 extension 1**  
[info@knoxcitycentre.ca](mailto:info@knoxcitycentre.ca)

108 Second Street East, Cornwall, ON  
[www.knoxcitycentre.ca](http://www.knoxcitycentre.ca)

**KING'S LANDING**

**Luxurious Apartments for Rent**

**2 Bedroom with Balcony, 4 Stainless Steel Kitchen Appliances. Supplied in-suite Laundry equipment.**

Please call for an appointment  
See info at: [www.kings-landing.ca](http://www.kings-landing.ca)  
or call **613-534-8400 extension #4**

1146 Montreal Road, Cornwall, ON  
Developed by JCS GODARD INVESTMENT INC



Stantec Consulting Ltd.  
300W-675 Cochrane Drive Markham ON L3R 0B8

August 25, 2016  
File: 160950878

**Attention:** «First\_Name» «Last\_Name», «Title»  
«Representing»  
«Address»  
«Town», «Province» «Postal\_Code»

Dear «First\_Name» «Last\_Name»,

**Reference: Barlow Solar Energy Centre**

On March 9, 2016, Barlow Energy Centre Limited Partnership was awarded a contract by the Independent Electricity System Operator for the proposed Barlow Solar Energy Centre (the Project), located in the Township of South Stormont (within the United Counties of Stormont, Dundas and Glengarry) and the City of Cornwall. Barlow Energy Centre Limited Partnership is now seeking a Renewable Energy Approval (REA) for the Project by the Ministry of the Environment and Climate Change as per Ontario Regulation 359/09 (the Regulation) - under Part V.0.1 of the *Environmental Protection Act*. If approved, the Project will have a total maximum name plate capacity of 10 megawatts and will be a Class 3 Solar Facility according to the provisions of the Regulation.

On behalf of Barlow Energy Centre Limited Partnership, please find enclosed a copy of the combined Notice of Proposal to Engage in a Renewable Energy Project and Notice of Public Meeting and the Draft Project Description Report (Draft PDR) for the Project. A newsletter to provide a brief project update is also enclosed. The Draft PDR is the first of several draft REA reports that will be distributed for review, and provides an overview of the Project, including the Project location, components, and potential impacts from the Project. The Draft Project Description Report can also be viewed online at [http://www.edf-en.ca/projects/project\\_display/barlow-solar-energy-centre1](http://www.edf-en.ca/projects/project_display/barlow-solar-energy-centre1). Barlow Energy Centre Limited Partnership is also requesting that you kindly make a copy of the Draft PDR and Notice of Public Meeting available at your local community office for public consumption. Information on how to submit comments on the Draft PDR is outlined below.

Barlow Energy Centre Limited Partnership is respectfully requesting any information that in your opinion should be considered in the development of the Project, including information on adverse impacts that the Project may have on constitutionally protected Aboriginal rights and any measures for mitigating those adverse impacts.

Additionally, and in accordance with the Regulation, the first Public Meeting is scheduled for October 5<sup>th</sup> (in the Township of South Stormont) and 6<sup>th</sup> (in the City of Cornwall) to provide an overview of the Project components, activities and potential environmental impacts, and to allow for the exchange of information with the stakeholders and Aboriginal community members. We invite you to extend this invitation to local community members to come and learn about the Project and to share their thoughts.



August 25, 2016

«First\_Name» «Last\_Name», «Title»

**Reference: Barlow Solar Energy Centre**

In addition, we note that the enclosed Notice will be published in the Cornwall Standard newspaper starting on September 1, 2016. Please let us know if:

- You would also like a copy of the Notice to be published in a newspaper within your community.
- You would like us to provide one or more additional hardcopies of the Draft PDR to make available to your community for display at a location of your choice.

We look forward to working with you, and obtaining your valuable input, as this project progresses through the regulatory approvals process. To submit written comments on the Draft PDR or to seek further information on the Project, please contact the undersigned and / or refer to the contact information below.

Kevin Campbell, Senior Developer  
Barlow Energy Centre Limited Partnership  
53 Jarvis Street, Ste. 300, Toronto, ON M5C 2H2  
Phone: (416) 216-5053  
Email: Kevin.Campbell@edf-en.ca

Regards,

**STANTEC CONSULTING LTD.**

Tanya Turk, M.Sc., P.Ag.  
Project Manager  
Phone: (905) 415-6416  
Tanya.Turk@stantec.com

Attachments: Notice of Proposal to Engage in a Renewable Energy Project and Notice of Public Meeting  
Draft Project Description Report  
Newsletter

cc. Kevin Campbell, Barlow Energy Centre Limited Partnership  
Fabiola Oribe, Barlow Energy Centre Limited Partnership



Stantec Consulting Ltd.  
300W-675 Cochrane Drive Markham ON L3R 0B8

August 25, 2016  
File: 160950878

**Attention:** «First\_Name\_» «Last\_Name\_», «Title»  
«Representing»  
«Address\_»  
«Town» «Province\_» «Postal\_Code\_»

Dear «First\_Name\_» «Last\_Name\_»,

**Reference: Barlow Solar Energy Centre**

On March 9, 2016, the Barlow Energy Centre Limited Partnership was awarded a contract by the Independent Electricity System Operator for the proposed Barlow Solar Energy Centre (the Project). The Project is located in the Township of South Stormont (within the United Counties of Stormont, Dundas and Glengarry) and the City of Cornwall. Barlow Energy Centre Limited Partnership is now seeking Renewable Energy Approval (REA) for the Project by the Ministry of the Environment and Climate Change as per Ontario Regulation 359/09 (the Regulation) - under Part V.0.1 of the *Environmental Protection Act*. If approved, the Project will have a total maximum name plate capacity of 10 megawatts and will be a Class 3 Solar Facility according to the provisions of the Regulation.

On behalf of Barlow Energy Centre Limited Partnership, please find enclosed a copy of the combined Notice of Proposal to Engage in a Renewable Energy Project and Notice of Public Meeting and the Draft Project Description Report (Draft PDR) for the Project. A newsletter to provide a brief project update is also enclosed. In accordance with the Regulation, the first Public Meeting is scheduled for October 5<sup>th</sup> and 6<sup>th</sup>, 2016 to provide an overview of the Project components, activities and potential environmental impacts, and to allow for the exchange of information with the public. The Draft PDR will be made available at the Public Meeting, and can also be viewed on the project website at [www.edf-en.ca/projects/project\\_display/barlow-solar-energy-centre1](http://www.edf-en.ca/projects/project_display/barlow-solar-energy-centre1).

We look forward to working with you, and obtaining your valuable input as this project progresses through the regulatory approvals process. We hope that you will attend the Public Meeting described in the attached notice. To submit written comments on the Draft PDR or to seek further information on the Project, please contact the undersigned and / or refer to the contact information below.

Kevin Campbell, Senior Developer  
Barlow Energy Centre Limited Partnership  
53 Jarvis Street, Ste. 300, Toronto, ON M5C 2H2  
Phone: (416) 216-5053

Design with community in mind



August 25, 2016  
Betty De Haan, CAO

Reference: Barlow Solar Energy Centre

Email: Kevin.Campbell@edf-en.ca

Regards,

**STANTEC CONSULTING LTD.**

Tanya Turk, M.Sc., P.Ag.  
Project Manager  
Phone: (905) 415-6416  
Tanya.Turk@stantec.com

Attachments: Notice of Proposal to Engage in a Renewable Energy Project and Notice of Public Meeting  
Draft Project Description Report  
Newsletter

cc. Kevin Campbell, Barlow Energy Centre Limited Partnership  
Fabiola Oribe, Barlow Energy Centre Limited Partnership

emv:\01609\active\160950879\planning\correspondence\cover\_letters\notice\_mtg\_pdr\_august 2016\municipal\ltr\_barlow\_clerk\_20160825.docx



Stantec Consulting Ltd.  
300W-675 Cochrane Drive Markham ON L3R 0B8

August 25, 2016  
File: 160950878

**Attention: Benjamin De Haan, Director of Transportation and Planning Services**  
City of Cornwall  
26 Pitt Street  
Cornwall, Ontario K6J 3P2

Dear Benjamin De Haan,

**Reference: Barlow Solar Energy Centre**

On March 9, 2016, the Barlow Energy Centre Limited Partnership was awarded a contract by the Independent Electricity System Operator for the proposed Barlow Solar Energy Centre (the Project). The Project is located in the Township of South Stormont (within the United Counties of Stormont, Dundas and Glengarry) and the City of Cornwall. Barlow Energy Centre Limited Partnership is now seeking Renewable Energy Approval (REA) for the Project by the Ministry of the Environment and Climate Change as per Ontario Regulation 359/09 (the Regulation) - under Part V.0.1 of the *Environmental Protection Act*. If approved, the Project will have a total maximum name plate capacity of 10 megawatts and will be a Class 3 Solar Facility according to the provisions of the Regulation.

On behalf of Barlow Energy Centre Limited Partnership, please find enclosed a copy of the combined Notice of Proposal to Engage in a Renewable Energy Project and Notice of Public Meeting and the Draft Project Description Report (Draft PDR) for the Project. A newsletter to provide a brief project update is also enclosed. In accordance with the Regulation, the first Public Meeting is scheduled for October 5<sup>th</sup> and 6<sup>th</sup>, 2016 to provide an overview of the Project components, activities and potential environmental impacts, and to allow for the exchange of information with the public. The Draft PDR will be made available at the Public Meeting, and can also be viewed on the project website at [www.edf-en.ca/projects/project\\_display/barlow-solar-energy-centre1](http://www.edf-en.ca/projects/project_display/barlow-solar-energy-centre1). Barlow Energy Centre Limited Partnership is also requesting that the municipality kindly make a copy of the Draft PDR and Notice of Public Meeting available at the Clerk's office for public consumption.

We look forward to working with you, and obtaining your valuable input as this project progresses through the regulatory approvals process. We hope that you will attend the Public Meeting described in the attached notice. To submit written comments on the Draft PDR or to seek further information on the Project, please contact the undersigned and / or refer to the contact information below.





August 25, 2016

**Benjamin De Haan, Director of Transportation and Planning Services**

**Reference: Barlow Solar Energy Centre**

Kevin Campbell, Senior Developer  
Barlow Energy Centre Limited Partnership  
53 Jarvis Street, Ste. 300, Toronto, ON M5C 2H2  
Phone: (416) 216-5053  
Email: Kevin.Campbell@edf-en.ca

Regards,

**STANTEC CONSULTING LTD.**

Tanya Turk, M.Sc., P.Ag.  
Project Manager  
Phone: (905) 415-6416  
Tanya.Turk@stantec.com

Attachments: Notice of Proposal to Engage in a Renewable Energy Project and Notice of Public Meeting  
Draft Project Description Report  
Newsletter

cc. Kevin Campbell, Barlow Energy Centre Limited Partnership  
Fabiola Oribe, Barlow Energy Centre Limited Partnership

emv:\01609\active\160950879\planning\correspondence\cover\_letters\notice\_mtg\_pdr\_august 2016\municipal\Ntr\_barlow\_clerk\_20160825.docx



Stantec Consulting Ltd.  
300W-675 Cochrane Drive Markham ON L3R 0B8

August 25, 2016  
File: 160950878

**Attention: Loriann Harbers, Director of Corporate Services / Clerk**  
Township of South Stormont  
P.O. Box 84  
2 Mille Roches Road  
Long Sault, Ontario K0C 1P0

Dear Loriann Harbers,

**Reference: Barlow Solar Energy Centre**

On March 9, 2016, the Barlow Energy Centre Limited Partnership was awarded a contract by the Independent Electricity System Operator for the proposed Barlow Solar Energy Centre (the Project). The Project is located in the Township of South Stormont (within the United Counties of Stormont, Dundas and Glengarry) and the City of Cornwall. Barlow Energy Centre Limited Partnership is now seeking Renewable Energy Approval (REA) for the Project by the Ministry of the Environment and Climate Change as per Ontario Regulation 359/09 (the Regulation) - under Part V.0.1 of the *Environmental Protection Act*. If approved, the Project will have a total maximum name plate capacity of 10 megawatts and will be a Class 3 Solar Facility according to the provisions of the Regulation.

On behalf of Barlow Energy Centre Limited Partnership, please find enclosed a copy of the combined Notice of Proposal to Engage in a Renewable Energy Project and Notice of Public Meeting and the Draft Project Description Report (Draft PDR) for the Project. A newsletter to provide a brief project update is also enclosed. In accordance with the Regulation, the first Public Meeting is scheduled for October 5<sup>th</sup> and 6<sup>th</sup>, 2016 to provide an overview of the Project components, activities and potential environmental impacts, and to allow for the exchange of information with the public. The Draft PDR will be made available at the Public Meeting, and can also be viewed on the project website at [www.edf-en.ca/projects/project\\_display/barlow-solar-energy-centre1](http://www.edf-en.ca/projects/project_display/barlow-solar-energy-centre1). Barlow Energy Centre Limited Partnership is also requesting that the municipality kindly make a copy of the Draft PDR and Notice of Public Meeting available at the Clerk's office for public consumption.

As required by the Regulation, a Municipal Consultation Form for the Project is attached. The consultation form is provided for the purpose of consulting on matters relating to municipal or local infrastructure and servicing, and will form the basis of our discussions surrounding the Project. As we progress through the REA process, additional project details (e.g., layout, technical reports, permit requirements) will be developed, provided, and confirmed in consultation with local lower- and upper-tier municipalities.



August 25, 2016

Loriann Harbers, Director of Corporate Services / Clerk

**Reference: Barlow Solar Energy Centre**

We look forward to working with you, and obtaining your valuable input as this project progresses through the regulatory approvals process. We hope that you will attend the Public Meeting described in the attached notice. To submit written comments on the Draft PDR or to seek further information on the Project, please contact the undersigned and / or refer to the contact information below.

Kevin Campbell, Senior Developer  
Barlow Energy Centre Limited Partnership  
53 Jarvis Street, Ste. 300, Toronto, ON M5C 2H2  
Phone: (416) 216-5053  
Email: Kevin.Campbell@edf-en.ca

Regards,

**STANTEC CONSULTING LTD.**

Tanya Turk, M.Sc., P.Ag.  
Project Manager  
Phone: (905) 415-6416  
Tanya.Turk@stantec.com

Attachments: Notice of Proposal to Engage in a Renewable Energy Project and Notice of Public Meeting  
Draft Project Description Report  
Newsletter  
Municipal Consultation Form

cc. Kevin Campbell, Barlow Energy Centre Limited Partnership  
Fabiola Oribe, Barlow Energy Centre Limited Partnership

emv:\01609\active\160950879\planning\correspondence\cover\_letters\notice\_mtg\_pdr\_august 2016\municipal\Ntr\_barlow\_clerk\_20160825.docx



Stantec Consulting Ltd.  
300W-675 Cochrane Drive Markham ON L3R 0B8

August 25, 2016  
File: 160950878

**Attention: Stephanie Morin, Planning Technical**

Township of South Stormont  
2 Mille Roches Road, PO Box 84  
Long Sault, Ontario K0C 1P0

Dear Stephanie Morin,

**Reference: Barlow Solar Energy Centre**

On March 9, 2016, the Barlow Energy Centre Limited Partnership was awarded a contract by the Independent Electricity System Operator for the proposed Barlow Solar Energy Centre (the Project). The Project is located in the Township of South Stormont (within the United Counties of Stormont, Dundas and Glengarry) and the City of Cornwall. Barlow Energy Centre Limited Partnership is now seeking Renewable Energy Approval (REA) for the Project by the Ministry of the Environment and Climate Change as per Ontario Regulation 359/09 (the Regulation) - under Part V.0.1 of the *Environmental Protection Act*. If approved, the Project will have a total maximum name plate capacity of 10 megawatts and will be a Class 3 Solar Facility according to the provisions of the Regulation.

On behalf of Barlow Energy Centre Limited Partnership, please find enclosed a copy of the combined Notice of Proposal to Engage in a Renewable Energy Project and Notice of Public Meeting and the Draft Project Description Report (Draft PDR) for the Project. A newsletter to provide a brief project update is also enclosed. In accordance with the Regulation, the first Public Meeting is scheduled for October 5<sup>th</sup> and 6<sup>th</sup>, 2016 to provide an overview of the Project components, activities and potential environmental impacts, and to allow for the exchange of information with the public. The Draft PDR will be made available at the Public Meeting, and can also be viewed on the project website at [www.edf-en.ca/projects/project\\_display/barlow-solar-energy-centre1](http://www.edf-en.ca/projects/project_display/barlow-solar-energy-centre1). Barlow Energy Centre Limited Partnership is also requesting that the municipality kindly make a copy of the Draft PDR and Notice of Public Meeting available at the Clerk's office for public consumption.

We look forward to working with you, and obtaining your valuable input as this project progresses through the regulatory approvals process. We hope that you will attend the Public Meeting described in the attached notice. To submit written comments on the Draft PDR or to seek further information on the Project, please contact the undersigned and / or refer to the contact information below.



August 25, 2016  
Stephanie Morin, Planning Technical

Reference: **Barlow Solar Energy Centre**

Kevin Campbell, Senior Developer  
Barlow Energy Centre Limited Partnership  
53 Jarvis Street, Ste. 300, Toronto, ON M5C 2H2  
Phone: (416) 216-5053  
Email: Kevin.Campbell@edf-en.ca

Regards,

**STANTEC CONSULTING LTD.**

Tanya Turk, M.Sc., P.Ag.  
Project Manager  
Phone: (905) 415-6416  
Tanya.Turk@stantec.com

Attachments: Notice of Proposal to Engage in a Renewable Energy Project and Notice of Public Meeting  
Draft Project Description Report  
Newsletter

cc. Kevin Campbell, Barlow Energy Centre Limited Partnership  
Fabiola Oribe, Barlow Energy Centre Limited Partnership

emv:\01609\active\160950879\planning\correspondence\cover\_letters\notice\_mtg\_pdr\_august 2016\municipal\Ntr\_barlow\_clerk\_20160825.docx



Stantec Consulting Ltd.  
300W-675 Cochrane Drive Markham ON L3R 0B8

August 25, 2016  
File: 160950878

**Attention: John St. Marseille, General Manager, Infrastructure & Municipal Works**  
City of Cornwall  
360 Pitt Street, Box 877  
Cornwall, Ontario K6J 3P9

Dear John St. Marseille,

**Reference: Barlow Solar Energy Centre**

On March 9, 2016, the Barlow Energy Centre Limited Partnership was awarded a contract by the Independent Electricity System Operator for the proposed Barlow Solar Energy Centre (the Project). The Project is located in the Township of South Stormont (within the United Counties of Stormont, Dundas and Glengarry) and the City of Cornwall. Barlow Energy Centre Limited Partnership is now seeking Renewable Energy Approval (REA) for the Project by the Ministry of the Environment and Climate Change as per Ontario Regulation 359/09 (the Regulation) - under Part V.0.1 of the *Environmental Protection Act*. If approved, the Project will have a total maximum name plate capacity of 10 megawatts and will be a Class 3 Solar Facility according to the provisions of the Regulation.

On behalf of Barlow Energy Centre Limited Partnership, please find enclosed a copy of the combined Notice of Proposal to Engage in a Renewable Energy Project and Notice of Public Meeting and the Draft Project Description Report (Draft PDR) for the Project. A newsletter to provide a brief project update is also enclosed. In accordance with the Regulation, the first Public Meeting is scheduled for October 5<sup>th</sup> and 6<sup>th</sup>, 2016 to provide an overview of the Project components, activities and potential environmental impacts, and to allow for the exchange of information with the public. The Draft PDR will be made available at the Public Meeting, and can also be viewed on the project website at [www.edf-en.ca/projects/project\\_display/barlow-solar-energy-centre1](http://www.edf-en.ca/projects/project_display/barlow-solar-energy-centre1).

We look forward to working with you, and obtaining your valuable input as this project progresses through the regulatory approvals process. We hope that you will attend the Public Meeting described in the attached notice. To submit written comments on the Draft PDR or to seek further information on the Project, please contact the undersigned and / or refer to the contact information below.

Kevin Campbell, Senior Developer  
Barlow Energy Centre Limited Partnership  
53 Jarvis Street, Ste. 300, Toronto, ON M5C 2H2  
Phone: (416) 216-5053  
Email: [Kevin.Campbell@edf-en.ca](mailto:Kevin.Campbell@edf-en.ca)

Design with community in mind



August 25, 2016

John St. Marseille, General Manager, Infrastructure & Municipal Works

Reference: Barlow Solar Energy Centre

Regards,

**STANTEC CONSULTING LTD.**

Tanya Turk, M.Sc., P.Ag.  
Project Manager  
Phone: (905) 415-6416  
Tanya.Turk@stantec.com

Attachments: Notice of Proposal to Engage in a Renewable Energy Project and Notice of Public Meeting  
Draft Project Description Report  
Newsletter

cc. Kevin Campbell, Barlow Energy Centre Limited Partnership  
Fabiola Oribe, Barlow Energy Centre Limited Partnership

emv:\01609\active\160950879\planning\correspondence\cover\_letters\notice\_mtg\_pdr\_august 2016\municipal\Ntr\_barlow\_clerk\_20160825.docx



Stantec Consulting Ltd.  
300W-675 Cochrane Drive Markham ON L3R 0B8

August 25, 2016  
File: 160950878

**Attention: Stephen Wintle, Division Manager, Infrastructure Planning**  
City of Cornwall  
360 Pitt Street Box 877  
Cornwall, Ontario K6J 3P9

Dear Stephen Wintle,

**Reference: Barlow Solar Energy Centre**

On March 9, 2016, the Barlow Energy Centre Limited Partnership was awarded a contract by the Independent Electricity System Operator for the proposed Barlow Solar Energy Centre (the Project). The Project is located in the Township of South Stormont (within the United Counties of Stormont, Dundas and Glengarry) and the City of Cornwall. Barlow Energy Centre Limited Partnership is now seeking Renewable Energy Approval (REA) for the Project by the Ministry of the Environment and Climate Change as per Ontario Regulation 359/09 (the Regulation) - under Part V.0.1 of the *Environmental Protection Act*. If approved, the Project will have a total maximum name plate capacity of 10 megawatts and will be a Class 3 Solar Facility according to the provisions of the Regulation.

On behalf of Barlow Energy Centre Limited Partnership, please find enclosed a copy of the combined Notice of Proposal to Engage in a Renewable Energy Project and Notice of Public Meeting and the Draft Project Description Report (Draft PDR) for the Project. A newsletter to provide a brief project update is also enclosed. In accordance with the Regulation, the first Public Meeting is scheduled for October 5<sup>th</sup> and 6<sup>th</sup>, 2016 to provide an overview of the Project components, activities and potential environmental impacts, and to allow for the exchange of information with the public. The Draft PDR will be made available at the Public Meeting, and can also be viewed on the project website at [www.edf-en.ca/projects/project\\_display/barlow-solar-energy-centre1](http://www.edf-en.ca/projects/project_display/barlow-solar-energy-centre1). Barlow Energy Centre Limited Partnership is also requesting that the municipality kindly make a copy of the Draft PDR and Notice of Public Meeting available at the Clerk's office for public consumption.

We look forward to working with you, and obtaining your valuable input as this project progresses through the regulatory approvals process. We hope that you will attend the Public Meeting described in the attached notice. To submit written comments on the Draft PDR or to seek further information on the Project, please contact the undersigned and / or refer to the contact information below.





August 25, 2016  
Stephen Wintle, Division Manager, Infrastructure Planning

Reference: Barlow Solar Energy Centre

Kevin Campbell, Senior Developer  
Barlow Energy Centre Limited Partnership  
53 Jarvis Street, Ste. 300, Toronto, ON M5C 2H2  
Phone: (416) 216-5053  
Email: Kevin.Campbell@edf-en.ca

Regards,

**STANTEC CONSULTING LTD.**

Tanya Turk, M.Sc., P.Ag.  
Project Manager  
Phone: (905) 415-6416  
Tanya.Turk@stantec.com

Attachments: Notice of Proposal to Engage in a Renewable Energy Project and Notice of Public Meeting  
Draft Project Description Report  
Newsletter

cc. Kevin Campbell, Barlow Energy Centre Limited Partnership  
Fabiola Oribe, Barlow Energy Centre Limited Partnership

emv:\01609\active\160950879\planning\correspondence\cover\_letters\notice\_mtg\_pdr\_august 2016\municipal\Ntr\_barlow\_clerk\_20160825.docx



Stantec Consulting Ltd.  
300W-675 Cochrane Drive Markham ON L3R 0B8

August 25, 2016  
File: 160950878

**Attention: Peter Young, Director of Planning/Economic Development Officer**  
Township of South Stormont  
2 Mille Roches Road, PO Box 84  
Long Sault, Ontario K0C 1P0

Dear Peter Young,

**Reference: Barlow Solar Energy Centre**

On March 9, 2016, the Barlow Energy Centre Limited Partnership was awarded a contract by the Independent Electricity System Operator for the proposed Barlow Solar Energy Centre (the Project). The Project is located in the Township of South Stormont (within the United Counties of Stormont, Dundas and Glengarry) and the City of Cornwall. Barlow Energy Centre Limited Partnership is now seeking Renewable Energy Approval (REA) for the Project by the Ministry of the Environment and Climate Change as per Ontario Regulation 359/09 (the Regulation) - under Part V.0.1 of the *Environmental Protection Act*. If approved, the Project will have a total maximum name plate capacity of 10 megawatts and will be a Class 3 Solar Facility according to the provisions of the Regulation.

On behalf of Barlow Energy Centre Limited Partnership, please find enclosed a copy of the combined Notice of Proposal to Engage in a Renewable Energy Project and Notice of Public Meeting and the Draft Project Description Report (Draft PDR) for the Project. A newsletter to provide a brief project update is also enclosed. In accordance with the Regulation, the first Public Meeting is scheduled for October 5<sup>th</sup> and 6<sup>th</sup>, 2016 to provide an overview of the Project components, activities and potential environmental impacts, and to allow for the exchange of information with the public. The Draft PDR will be made available at the Public Meeting, and can also be viewed on the project website at [www.edf-en.ca/projects/project\\_display/barlow-solar-energy-centre1](http://www.edf-en.ca/projects/project_display/barlow-solar-energy-centre1).

We look forward to working with you, and obtaining your valuable input as this project progresses through the regulatory approvals process. We hope that you will attend the Public Meeting described in the attached notice. To submit written comments on the Draft PDR or to seek further information on the Project, please contact the undersigned and / or refer to the contact information below.

Kevin Campbell, Senior Developer  
Barlow Energy Centre Limited Partnership  
53 Jarvis Street, Ste. 300, Toronto, ON M5C 2H2  
Phone: (416) 216-5053  
Email: [Kevin.Campbell@edf-en.ca](mailto:Kevin.Campbell@edf-en.ca)

Design with community in mind



August 25, 2016  
Peter Young, Director of Planning/Economic Development Officer

Reference: Barlow Solar Energy Centre

Regards,

**STANTEC CONSULTING LTD.**

Tanya Turk, M.Sc., P.Ag.  
Project Manager  
Phone: (905) 415-6416  
Tanya.Turk@stantec.com

Attachments: Notice of Proposal to Engage in a Renewable Energy Project and Notice of Public Meeting  
Draft Project Description Report  
Newsletter

cc. Kevin Campbell, Barlow Energy Centre Limited Partnership  
Fabiola Oribe, Barlow Energy Centre Limited Partnership

emv:\01609\active\160950879\planning\correspondence\cover\_letters\notice\_mtg\_pdr\_august 2016\municipal\Ntr\_barlow\_clerk\_20160825.docx



Stantec Consulting Ltd.  
300W-675 Cochrane Drive Markham ON L3R 0B8

August 25, 2016  
File: 160950878

**Attention: Manon Levesque, Deputy City Clerk**

City of Cornwall  
360 Pitt Street, Box 877  
Cornwall, Ontario K6H 5T9

Dear Manon Levesque,

**Reference: Barlow Solar Energy Centre**

On March 9, 2016, the Barlow Energy Centre Limited Partnership was awarded a contract by the Independent Electricity System Operator for the proposed Barlow Solar Energy Centre (the Project). The Project is located in the Township of South Stormont (within the United Counties of Stormont, Dundas and Glengarry) and the City of Cornwall. Barlow Energy Centre Limited Partnership is now seeking Renewable Energy Approval (REA) for the Project by the Ministry of the Environment and Climate Change as per Ontario Regulation 359/09 (the Regulation) - under Part V.0.1 of the *Environmental Protection Act*. If approved, the Project will have a total maximum name plate capacity of 10 megawatts and will be a Class 3 Solar Facility according to the provisions of the Regulation.

On behalf of Barlow Energy Centre Limited Partnership, please find enclosed a copy of the combined Notice of Proposal to Engage in a Renewable Energy Project and Notice of Public Meeting and the Draft Project Description Report (Draft PDR) for the Project. A newsletter to provide a brief project update is also enclosed. In accordance with the Regulation, the first Public Meeting is scheduled for October 5<sup>th</sup> and 6<sup>th</sup>, 2016 to provide an overview of the Project components, activities and potential environmental impacts, and to allow for the exchange of information with the public. The Draft PDR will be made available at the Public Meeting, and can also be viewed on the project website at [www.edf-en.ca/projects/project\\_display/barlow-solar-energy-centre1](http://www.edf-en.ca/projects/project_display/barlow-solar-energy-centre1). Barlow Energy Centre Limited Partnership is also requesting that the municipality kindly make a copy of the Draft PDR and Notice of Public Meeting available at the Clerk's office for public consumption.

As required by the Regulation, a Municipal Consultation Form for the Project is attached. The consultation form is provided for the purpose of consulting on matters relating to municipal or local infrastructure and servicing, and will form the basis of our discussions surrounding the Project. As we progress through the REA process, additional project details (e.g., layout, technical reports, permit requirements) will be developed, provided, and confirmed in consultation with local lower- and upper-tier municipalities.

We look forward to working with you, and obtaining your valuable input as this project progresses through the regulatory approvals process. We hope that you will attend the Public Meeting

Design with community in mind



August 25, 2016  
Manon Levesque, Deputy City Clerk

**Reference: Barlow Solar Energy Centre**

described in the attached notice. To submit written comments on the Draft PDR or to seek further information on the Project, please contact the undersigned and / or refer to the contact information below.

Kevin Campbell, Senior Developer  
Barlow Energy Centre Limited Partnership  
53 Jarvis Street, Ste. 300, Toronto, ON M5C 2H2  
Phone: (416) 216-5053  
Email: Kevin.Campbell@edf-en.ca

Regards,

**STANTEC CONSULTING LTD.**

Tanya Turk, M.Sc., P.Ag.  
Project Manager  
Phone: (905) 415-6416  
Tanya.Turk@stantec.com

Attachments: Notice of Proposal to Engage in a Renewable Energy Project and Notice of Public Meeting  
Draft Project Description Report  
Newsletter  
Municipal Consultation Form

cc. Kevin Campbell, Barlow Energy Centre Limited Partnership  
Fabiola Oribe, Barlow Energy Centre Limited Partnership

emv:\01609\active\160950879\planning\correspondence\cover\_letters\notice\_mtg\_pdr\_august 2016\municipal\Ntr\_barlow\_clerk\_20160825.docx

The Barlow Newsletter is designed to provide you with the latest information about the Barlow Solar Energy Centre. This publication will help you learn about the project, its timelines, anticipated benefits and provide project contact information.

## ABOUT THE PROJECT

Selected by the Independent Electricity System Operator (IESO) under the Large Renewable Procurement I Request for Proposals ("LRP I RFP"), Barlow Solar Energy Centre is being realized by a partnership between EDF EN Canada and the Algonquins of Pikwàkanagàn First Nation.

The project will be situated on privately-owned land located within the Township of South Stormont and

utilize a right of way within the City of Cornwall to connect to the existing electricity distribution grid. Barlow Solar Energy Centre will have a capacity of 10 megawatts alternating current (MWac) and will generate enough power to meet the demand of about 2,000 homes.

Construction is planned for 2018, following the receipt of required provincial and municipal approvals and permits. Commercial operation is expected by the end of 2018.

## COMMUNITY BENEFITS

**The Township of South Stormont, county, as well as associated school boards and local residents will realize many benefits, including:**

- A Community Benefit Agreement to contribute funds on an annual basis to the Township of South Stormont for improving local infrastructure and services (nearly \$480,000 over the life of the project).
- Additional property tax revenues generated by the project that will help to supplement revenues for the Township of South Stormont, county and local school boards (nearly \$400,000 over the life of the project).
- Nearly one hundred (100) construction jobs at the peak of construction, providing opportunities for local employment and the hospitality sector.
- Important opportunities for the local and surrounding economy during construction through: the procurement of local services, contractors and materials for project construction (i.e. aggregate, landscaping, etc.).

## PROJECT TIMELINE

\*MOECC - Ministry of Environment and Climate Change  
Note: Public consultation continues throughout each phase of the project



# PROJECT STUDIES



SAMPLE OF ARCHAEOLOGICAL FIELD WORK

A number of studies are necessary as part of the approvals and permitting process. The following studies are either complete or underway:

- A natural heritage site investigation to identify if sensitive natural features such as wetlands or significant woodlands exist on or within 50m of the Project Location.
- An aquatic site investigation to identify if aquatic features, such as water bodies or streams, exist within 120 m of the Project Location.
- An archaeology assessment to determine the archaeological potential of the Project Location.
- A review of cultural heritage resources to identify heritage sites within or adjacent to the Project Location.

These studies identify sensitive features and identify mitigation measures to protect these features. No archaeological resources have been recovered during the Stage 2 Archaeology Assessment to date.

The noise assessment is an important study to be conducted later this year to confirm that sound propagating from project equipment during operation is less than 40 dB (equivalent to a quiet room) at the exterior of neighboring homes.

More details will be shared with the public and municipal and provincial agencies in the coming months as we complete our studies and associated reports.



TEST PIT SURVEY

## HOW SOLAR WORKS

- 1 - Energy from the sun falls onto the earth's surface each day in the form of sunlight.
- 2 - The sunlight is absorbed by the solar panel, converting sunlight into electricity.
- 3 and 4 - Electricity generated travels through distribution lines to homes and businesses.

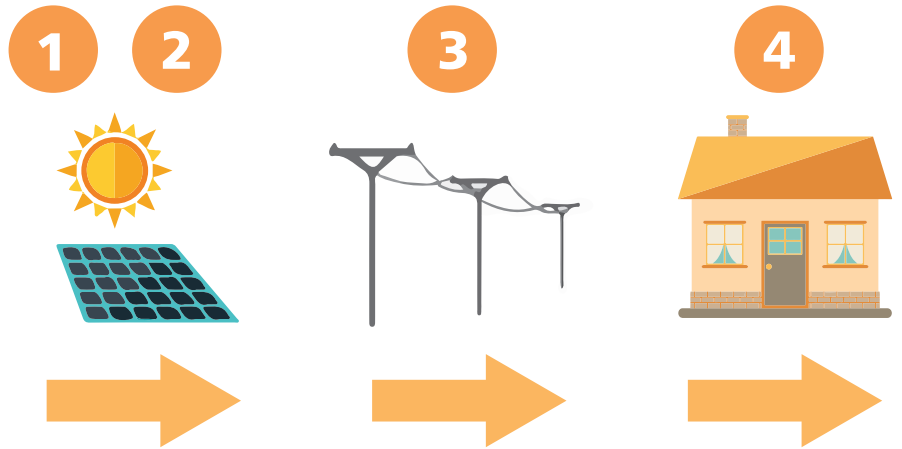

Crédits illustrations: 123rf -Yulia Drozdova; neonicflower

## STAY TUNED!

The second open house for the Barlow Solar Energy Centre is scheduled for Wednesday, October 5th (South Stormont Community Hall) and Thursday, October 6th (Best Western Plus Parkway Cornwall), from 5 PM to 8 PM. This is an opportunity for you to learn more about the solar energy centre and share with us your interests that should be considered during project planning. We encourage you to call or email us to be added to our mailing list, to share your thoughts about the project, or if you have any questions.

The project newsletter and open house details will also be on our website:  
[http://edf-en.ca/projects/project\\_display/barlow-solar-energy-centre1](http://edf-en.ca/projects/project_display/barlow-solar-energy-centre1)

### CONTACT US

Fabiola Oribe, Associate Developer and Stakeholder Relations.

Email: [BarlowSolar@edf-en.ca](mailto:BarlowSolar@edf-en.ca) / Phone: 1-844-55-EDF-EN





February 21, 2017

File: 160950879

**Attention:** «First\_Name» «Last\_Name»

«Representing»

«Address»

«Town» «Province» «Postal\_Code»

Dear «First\_Name»,

**Reference: Barlow Solar Energy Centre  
Notice of Second Public Meeting and 60 Day Public Review of Draft REA Documents**

Barlow Energy Centre Limited Partnership, is proposing the development of a 10 megawatt alternating current solar energy generating facility, known as the Barlow Solar Energy Centre (the Project) approximately 10 kilometres west of the city centre of Cornwall in the Township of South Stormont, United Counties of Stormont, Dundas and Glengarry, and in the City of Cornwall, Ontario. The Point of Common Coupling will be located adjacent to the Project Location, within the road allowance of Cornwall Centre Road, in the City of Cornwall, Ontario. The Project will require a Renewable Energy Approval (REA) in accordance with Ontario Regulation (O. Reg.) 359/09.

Please find attached a Newsletter, as well as the Notice of Second Public Meeting for the Project. This Notice will be published in the Cornwall Standard Freehold.

Under O. Reg. 359/09, draft REA documents required as part of the REA application for the Project are to be made available for public review and comment for a period of at least 60 days prior to the second public meeting. These draft REA documents will be made available to the community prior to the public meeting at the review locations indicated on the Notice, and on the Project website ([www.edf-en.ca/project/barlow-solar-energy-centre](http://www.edf-en.ca/project/barlow-solar-energy-centre)). The draft REA documents will also be available for review at the public meetings. Please notify us should you require a copy of the documents, and we would be pleased to provide them to you.

You have been included on the consultation distribution list as you own property in the vicinity of the Project location or have expressed an interest in the Project. We hope that you will attend the upcoming public meetings, which will be a drop-in style format (see attached Notice for details). In the meantime, if you would like to submit comments regarding the draft REA documents or the Project, or would like further information, please visit the Project website or contact the undersigned.





We look forward to obtaining your input for consideration as this Project progresses through the REA process.

Regards,

**Barlow Energy Centre Limited Partnership**

A handwritten signature in black ink that reads "Fabiola J. Oribe".

**Fabiola Oribe**

Associate Project Developer and Stakeholder Relations

Project Email Address: [BarlowSolar@edf-en.ca](mailto:BarlowSolar@edf-en.ca)

Toll-Free Phone Number: 1-844-55-EDF-EN

Project Website: [www.edf-en.ca/project/barlow-solar-energy-centre](http://www.edf-en.ca/project/barlow-solar-energy-centre)

Attachment: Notice of Second Public Meeting

- c. Kevin Campbell, Barlow Energy Centre Limited Partnership  
Tanya Turk, Stantec Consulting Ltd.



February 16, 2017

File: 160950879

**Attention:** «Title» «First\_Name» «Last\_Name», «Position»

«Agency»

«Address»

«City» «Prov» «Postal»

Dear «Title» «First\_Name» «Last\_Name»,

**Reference: Barlow Solar Energy Centre  
Notice of Second Public Meeting and 60 Day Public Review of Draft Documents**

Barlow Energy Centre Limited Partnership is proposing the development of a 10 megawatt alternating current (MWac) solar energy generating facility, known as the Barlow Solar Energy Centre (the Project) approximately 10 kilometres (km) west of the city centre of Cornwall in the Township of South Stormont, United Counties of Stormont, Dundas and Glengarry, Ontario and in the City of Cornwall. The Point of Common Coupling will be located adjacent to the Project Location, on the road allowance of Cornwall Centre Road, in the City of Cornwall, Ontario. The Project will require a Renewable Energy Approval (REA) in accordance with Ontario Regulation (O. Reg.) 359/09.

Please find attached a Newsletter and a Notice of Second Public Meeting for the Project. This Notice will be published in the Cornwall Standard Freehold in February 2017. If you have a publication or newspaper that is distributed within your community, we would be interested in publishing our Notice. Please let us know by contacting the undersigned.

Barlow Energy Centre Limited Partnership and the Project Team have prepared the following draft REA documents required as part of the REA application for the Project, and under O. Reg. 359/09, they have been enclosed in hard copy and CD, for review and comment for a period of at least 60 days prior to the public meetings:

- Project Description Report
- Construction Plan Report
- Design and Operations Report
- Decommissioning Plan Report
- Acoustic Assessment Report
- Natural Heritage Assessment and Environmental Impact Study
- Water Assessment and Water Body Report
- Stages 1 and 2 Archaeological Assessment Report
- REA Checklist: Consideration of Potential for Heritage Resources

In addition, we have prepared and enclosed a draft Project Summary Report that provides a summary of each draft document noted above.

**Information Request**

We are seeking input from your community to be considered in the completion of these Project documents.



As outlined in subsection 17.1.4 of Ontario Regulation 359/09 as amended (the REA Regulation), we would like to request that you provide, in writing:

- any information that, in your community's opinion, should be considered in preparing the REA reports;
- any information your community may have about any potential adverse impacts the Project may have on Aboriginal or treaty rights; and,
- any suggested measures for avoiding, minimizing, or mitigating potential adverse impacts.

We hope representatives from Algonquins of Pikwakanagan First Nation will attend the upcoming public meetings, which will be a drop-in style format (see Notice for details). We are also flexible to meet or receive feedback outside of these public meetings. In the meantime, if you would like to submit comments regarding the draft reports or the Project, or would like further information, please visit the Project website provided above or contact the Project team directly:

Project Email Address: [BarlowSolar@edf-en.ca](mailto:BarlowSolar@edf-en.ca)  
Toll-Free Phone Number: 1-844-55-EDF-EN  
Project Website: [www.edf-en.ca/project/barlow-solar-energy-centre](http://www.edf-en.ca/project/barlow-solar-energy-centre)

We look forward to your feedback and obtaining your valuable input, as this Project progresses through the REA process.

Respectfully,

**Barlow Energy Centre Limited Partnership**

A handwritten signature in black ink, appearing to read "K. Campbell", is positioned above the printed name of the signatory.

**Kevin Campbell**  
Senior Developer  
Tel: 416-216-5053  
Email: [Kevin.Campbell@edf-en.ca](mailto:Kevin.Campbell@edf-en.ca)

Attachments: Barlow Newsletter  
Notice of Second Public Meeting  
1 Binder and CD including:  
Project Summary Report  
Project Description Report  
Construction Plan Report  
Design and Operations Report  
Decommissioning Plan Report  
Noise Study Report  
Natural Heritage Assessment and Environmental Impact Study  
Water Assessment and Water Body Report  
Stage 1 and 2 Archaeological Assessment Report  
REA Checklist: Consideration of Potential for Heritage Resources

The Barlow Newsletter is designed to provide you with the latest information about the Barlow Solar Energy Centre. This publication will help you learn about the project, its timelines, anticipated benefits and provide project contact information.

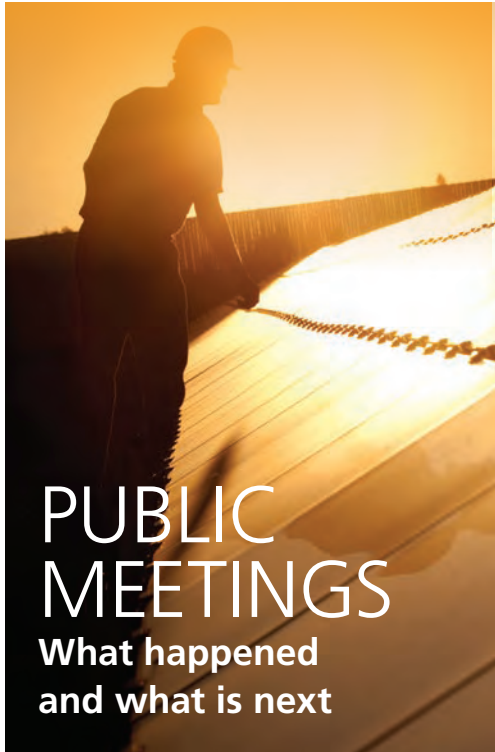

## PUBLIC MEETINGS

What happened and what is next

### First Public Meeting

The First Public Meeting for the Barlow Solar Energy Centre was held on October 5th and 6th in Cornwall and South Stormont, and was a great opportunity for the community to learn about the project, meet the team members, ask questions and leave their comments.

According to the feedback forms submitted by a dozen local citizens, the environment was the issue of most interest communicated by the attendees. Most participants indicated that they were satisfied with the information provided by members of the project team in attendance, which included our environmental consultant, construction manager, development manager and stakeholder relations personnel.

Please consult the following link to view a copy of the First Public Meeting boards: [http://www.edf-en.ca/wp-content/uploads/2016/09/30\\_BAR\\_36x24-REA-Solar\\_Story\\_Boards.pdf](http://www.edf-en.ca/wp-content/uploads/2016/09/30_BAR_36x24-REA-Solar_Story_Boards.pdf).

### Second Public Meeting Scheduled

If you didn't have a chance to attend the previous meeting or if you would like to keep following the project progress, don't miss the opportunity to participate in the Second Public Meeting. This is a chance for you to learn more about the project and share your interests. The team will be glad to provide project updates and answer any questions you may have.

**MONDAY APRIL 24TH, 2017**  
4:00 p.m. – 7:00 p.m.

Best Western Parkway Inn & Conference Centre  
1515 Vincent Massey Drive  
Cornwall - Ontario

**TUESDAY APRIL 25TH, 2017**  
4:00 p.m. – 7:00 p.m.

South Stormont Community Hall  
2 Mille Roches Road  
Long Sault - Ontario

## SUNNY & HONEY

# 100%

## ARNPRIOR SOLAR HONEY



When it comes to environmental benefits, solar can offer more than clean electricity. EDF EN Canada, working closely with local stakeholders, took advantage of the wild flowers and clover that typically grow within a solar park, including beneath the solar panels. During the summer of 2016, beehives were installed in the vicinity of Arnprior Solar park to enhance the biodiversity of the project by producing honey. Though initiated in late summer of 2016, just shy of 70 honey jars were produced in 2016. To further increase solar honey production, more hives are planned for 2017. Collection of more than 350 jars are anticipated. The honey produced is given as a gift to the company employees, partners and projects stakeholders.

Located near Ottawa, Arnprior Solar is a clean, safe and renewable energy source, meeting the peak energy demands of about 3 700 homes. To learn more, visit the Arnprior Solar website at: [www.edf-en.ca/project/arnprior-solar](http://www.edf-en.ca/project/arnprior-solar)



## PROJECT TIMELINE



There will be little to no construction activity in 2017. The bulk of the activity will be during the spring, summer and fall of 2018, when the site will be prepared, equipment will be installed and the project will be commissioned. We will provide further details as opportunities for jobs or provision of services and dates related to construction become known.



# PROJECT UPDATE

In the past few months, the project team along with the environmental consultant, Stantec Consulting Ltd., completed several studies and draft Renewable Energy Approval (REA) documents to support the REA Application, anticipated to be submitted in the spring of 2017. Draft REA documents completed include those shown in this chart.

All studies and reports are now available for public viewing via the project website (<http://www.edf-en.ca/project/barlow-solar-energy-centre/>). Copies of the documents are also available at the Township of South Stormont municipal office and City of Cornwall municipal office.

REA DOCUMENTS	SUMMARY
PROJECT SUMMARY REPORT	A summary of each of the project reports identified below
PROJECT DESCRIPTION REPORT	Outlines the project including project components, anticipated schedule, authorizations potentially required and potential environmental effects.
CONSTRUCTION PLAN REPORT	Includes a summary of project construction and installation activities, potential construction environmental effects and mitigation measures.
DESIGN AND OPERATIONS REPORT	Provides an overview of the project site plan, as well as potential operational environmental effects and mitigation. Includes discussion on emergency response and communications plan.
DECOMMISSIONING PLAN REPORT	A summary of project decommissioning activities, potential decommissioning environmental effects and mitigation measures.
STAGE 1 AND 2 ARCHAEOLOGICAL ASSESSMENT	Provides an overview of the methodology and results of the Stage 1 (desktop) and Stage 2 (field study), and outlines the potential for the existence of archaeological resources within the Project Location boundary.
NATURAL HERITAGE ASSESSMENT / ENVIRONMENTAL IMPACT STUDY	Summarizes the findings of the terrestrial background research and field studies undertaken for the project. Identifies and proposes mitigation measures for significant natural heritage features identified within and surrounding the Project Location.
WATER ASSESSMENT AND WATER BODY REPORT	Summarizes the findings of the aquatic background research and field studies undertaken for the project. Identifies and proposes mitigation measures for water bodies identified within and adjacent to the Project Location.
ACOUSTIC ASSESSMENT REPORT	Identifies receptors and the propagation of sound from the facility to predict if sound from project will be limited to 40 dB (equivalent to a quiet room), at applicable neighboring receptors.

## GREEN QUESTION

Did you know solar PV is the fastest growing form of new electricity in the world? Consider these statistics:

**260,000+**  
employed

in the solar industry in the United States

(Source: <http://www.seia.org/news/american-solar-job-force-hits-new-record-growth-now-stands-260000-strong>)

**65%**  
decrease in cost

of solar electricity in Canada since 2009

(Source: <http://news.mediaedge.ca/newsletter.aspx?nid=17800765-e8c5-4689-b266-53dd424a1efd>)

**\$1 billion+**  
investments  
**10,000**  
jobs

created by the solar industry in Canada annually

(Source: <http://issues.solarindustrymag.com/article/canadas-solar-market-to-enter-a-new-phase-in-2017>)

**7,000+**  
solar panels  
per day

on average were connected to the grid in Canada in 2015

(Source: <http://news.mediaedge.ca/newsletter.aspx?nid=6df1ee29-c268-4525-a6ef-a59784f07a3f>)

**First time**

globally, new installations of renewable energy overtook conventional power in 2015

(Source: <https://www.bloomberg.com/news/articles/2016-10-25/record-green-power-installations-beat-fossil-fuel-for-first-time>)



### CONTACT US

Fabiola Oribe, Associate Developer and Stakeholder Relations.

**Email: [BarlowSolar@edf-en.ca](mailto:BarlowSolar@edf-en.ca) / Phone: 1-844-55-EDF-EN**



# APPENDIX B PUBLIC MEETING DISPLAY BOARDS



**WELCOME!**

Thank you for attending the First Public Meeting Under the Renewable Energy Approval (REA) Process for the **Barlow Solar Energy Centre!**

We are here to share new information about this clean, **renewable energy** project with you. Keep in mind that we are still completing various studies and reports, as well as project design. Today's intent is to collect additional input from the community to incorporate into our design.

Please review the display boards and feel free to ask us any questions you may have.

**We want to hear from you!**

Please complete a comment form to share your feedback!  
If you would like to be added to the Project mailing list, please sign up at the front desk.

EDF EN

A LEADER IN  
RENEWABLE  
ENERGY

## Among the Top 10 Global Players

### GENERATION ACTIVITY

- **8 989 MW**  
gross installed
- **1 620 MW**  
gross under construction\*
- **10.4 billion kWh**  
of green electricity generated in 2015

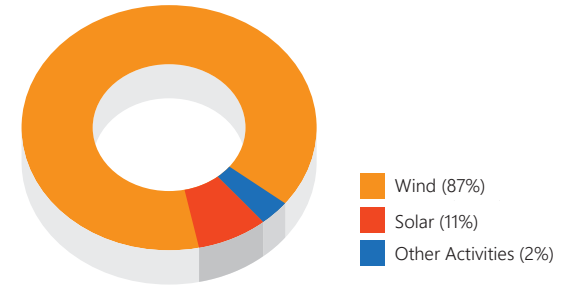

### COMPLEMENTARY ACTIVITIES

- **3 201 MW**  
developed, built and commissioned
- **14 323 MW**  
in operations and maintenance\*

*\* For own account and for third-parties*

21 countries throughout North America, South America, Europe, Africa, the Middle East, and India

> 3 000 employees



# EDF EN CANADA

1 600+ MW  
OF WIND  
AND SOLAR  
ACROSS  
CANADA

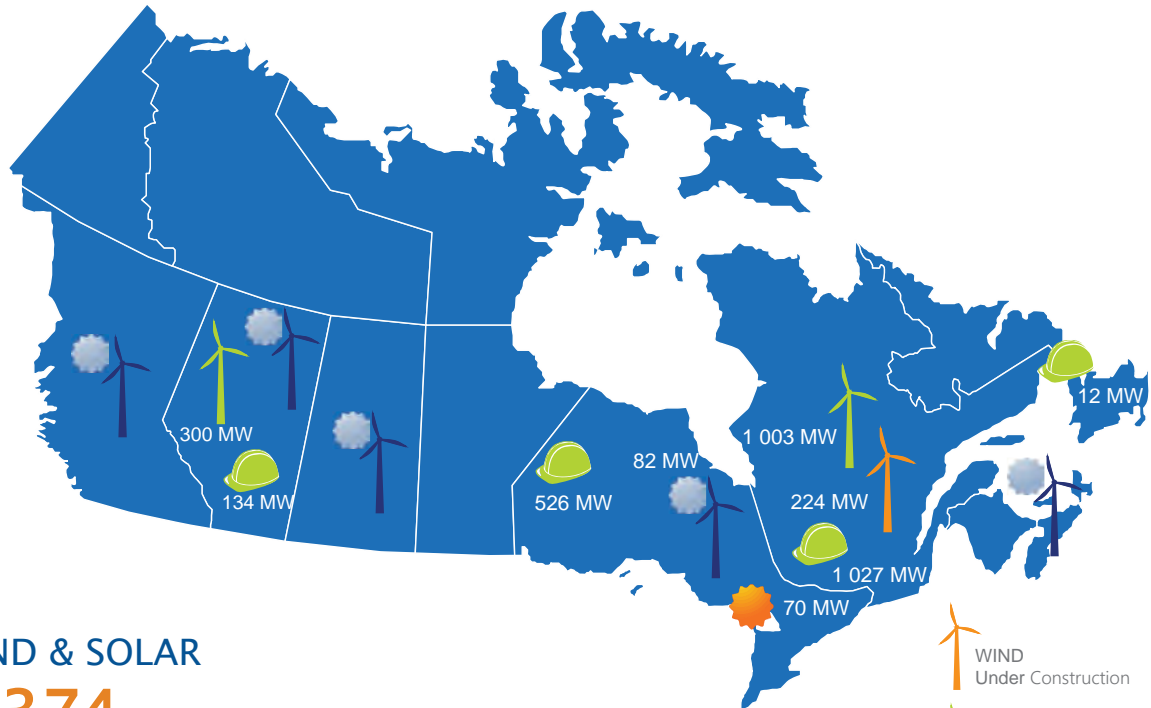

## WIND & SOLAR

**1 374 MW** (350 000 homes) Commissioned Capacity

**224 MW** (54 900 homes) Under Construction

**82 MW** (20 100 homes) In Development

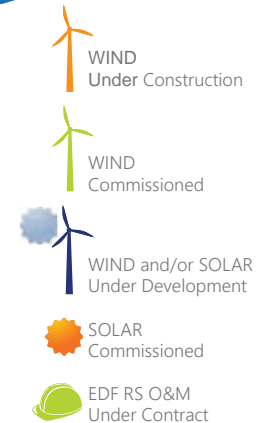

## OPERATIONS & MAINTENANCE

**1 173 MW** Wind

**526 MW** Solar

**>\$3.5 billion** invested  
in Canada since 2008



## PROJECT OVERVIEW

**PROJECT NAME:** Barlow Solar Energy Centre

**PROJECT OWNERS:** EDF EN Canada and the Algonquins of Pikwàkanagàn First Nation

**HOST MUNICIPALITIES:** Township of South Stormont and City of Cornwall

**RENEWABLE FUEL:** Non-Rooftop Solar

**CONTRACT CAPACITY:** 10 MWac

### PROPOSED CONNECTION POINT

Located within the City of Cornwall, on an existing distribution line along Power Dam Drive, about 600 metres east of the Site near the intersection of Cornwall Centre Rd. and Power Dam Dr.

### CONNECTION LINE

The Connection Line will run approximately 900 m eastward along Cornwall Centre Rd., using the road allowance belonging to the City of Cornwall, from the Site to the Connection Point.

# PROJECT LOCATION

Located on 94 acres of privately owned land, in the Township of South Stormont and the City of Cornwall.



# PRELIMINARY SITE PLAN

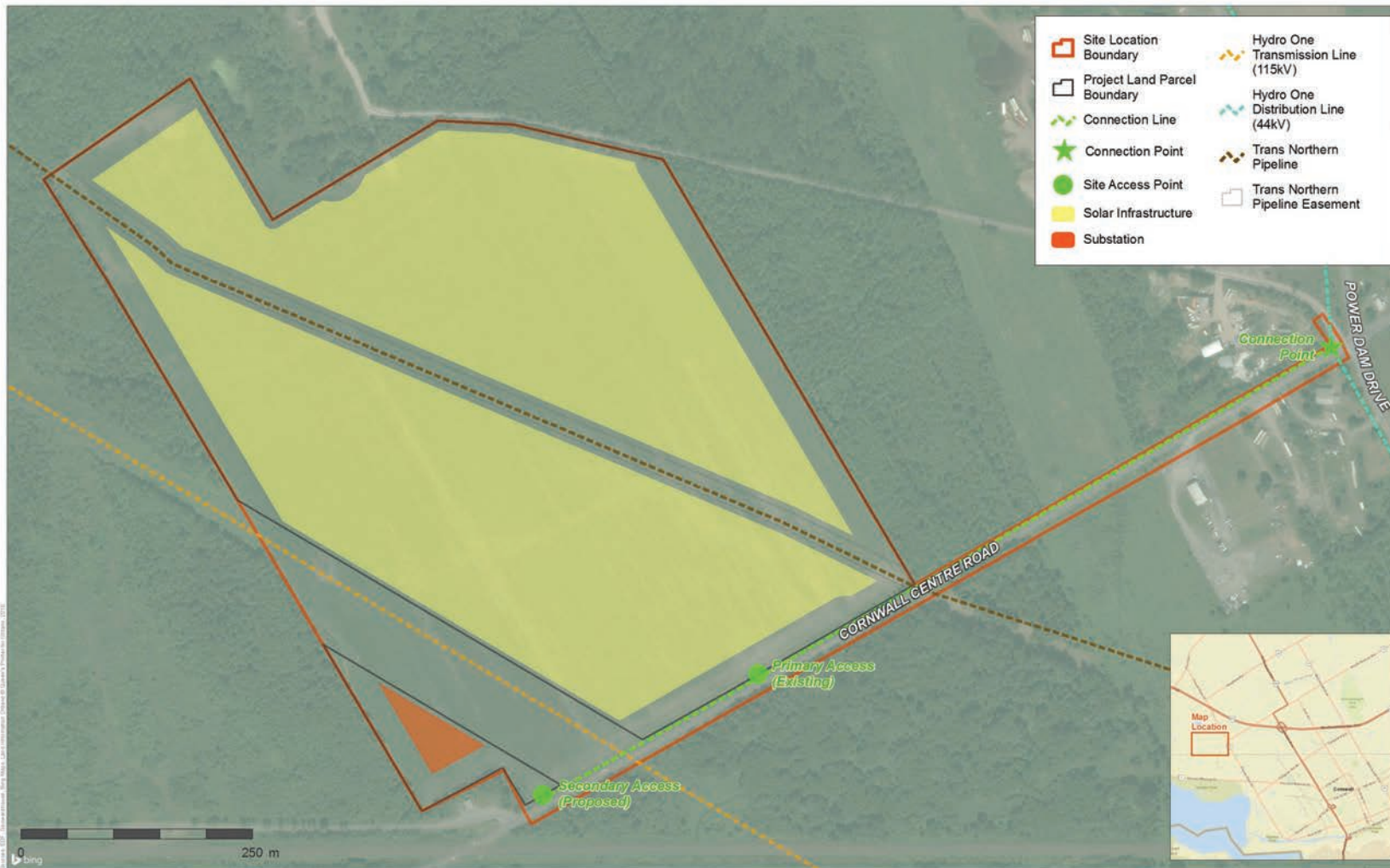

- Final locations for Project infrastructure will be considered through public consultation and engineering / environmental studies.

# SOLAR ENERGY: HOW DOES IT WORK?



- 1** Energy from the sun falls onto the earth's surface each day in the form of sunlight.
- 2** The sunlight is absorbed by the solar panels, converting sunlight into electricity.
  - Solar cells are small, square-shaped silicon semiconductors. Each solar cell is connected into a network of many other solar cells to create a PV (photovoltaic) module or panel. A solar facility is comprised of thousands of panels.
- 3** The absorbed sunlight is transformed into usable energy by way of an inverter that turns direct current (DC) energy into alternating current (AC) electricity. AC is the form of power used in homes and businesses.
- 4** Electricity generated travels through distribution lines to homes and businesses.

# SOLAR PARK EQUIPMENT



# SOLAR PARK EQUIPMENT



- Final technology not yet determined. Either solar panels mounted on a single axis tracker system (left), or solar panels mounted on a fixed tilt system (right).
- Four to six inverters / transformers will be scattered within the site to convert electricity from direct current to alternating current and raise the voltage from ~1 000 volts to 27 600 volts.
- Cabling connecting 1) solar panels to inverters/transformers and 2) inverters/transformers to substation usually buried underground.

## TRACKING SOLAR PANELS:

## HOW DO THEY WORK?

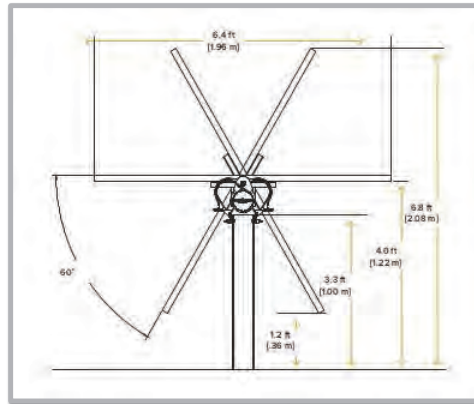

- A tracker is a type of racking system that follows the sun as it arcs through the sky – ensuring the panels always face the sun.
- The motors are solar powered, thereby eliminating the need for external power.
- The panels are mounted in rows on a north/south axis. A tracking motor is located in the middle of each row.
- Wireless communication between each row controls the movement of the panels and alerts operators to any errors.



# THE RENEWABLE ENERGY APPROVAL PROCESS

## Overview of Renewable Energy Approval Process

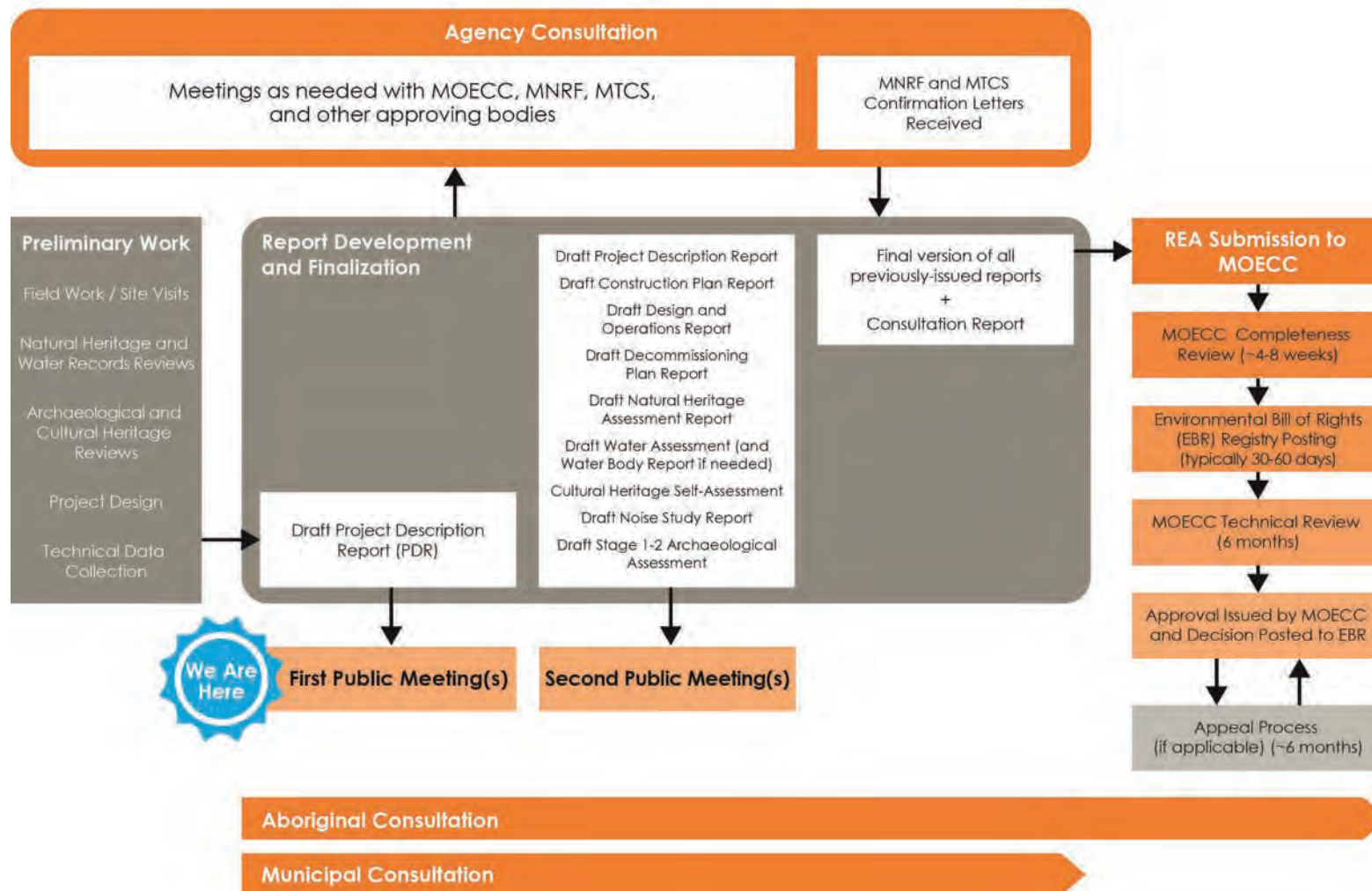

- Issued under Ontario Regulation 359/09 under the Environmental Protection Act.
- Stringent environmental approval process that needs to be satisfied before construction.
- Specifies how the Project will be designed, built, operated and decommissioned so that the environment is protected.

# ENVIRONMENTAL AND TECHNICAL ACTIVITIES UNDERWAY

- **Solar Collection**

Meteorological (MET) station erected at site to monitor amount of energy from the sun at site to help with estimating potential electricity production over the life of the Project.

- **Geotechnical Assessment**

Determine the type of soils and depth to bedrock to better understand how the foundations will be designed and built.

- **Environmental & Cultural Field Work**

The following technical studies help us to understand the local environment and to avoid or mitigate potential impacts of the Project: wildlife & wildlife habitat, waterbodies and aquatic resources, woodlands, wetlands, and other vegetation communities, archaeological resources, cultural heritage features, socio-economic features.

- **Interconnection Assessment**

Interconnection studies are performed by Hydro One Networks Inc. (HONI) and the Independent Electricity System Operator (IESO) to ensure the safe and reliable integration of solar energy. The assessments confirm the ability to connect to the grid.



# DESCRIPTION OF POTENTIAL ENVIRONMENTAL EFFECTS

## Natural Heritage Resources

- The Project Location is situated within an active agricultural area and not within a natural feature.
- Natural heritage features located within 50 m of the Project Location are assessed for significance. Appropriate mitigation measures are planned for any anticipated environmental effects.
- The Project Location is not located within 50 m of a Provincial Park, Conservation Reserve, or an Area of Natural and Scientific Interest.

## Heritage & Archaeological Resources

- Heritage and archaeological studies were completed according to the requirements of the Ministry of Tourism, Culture and Sport.
- No heritage resources or protected properties were identified.
- No evidence of archaeological sites/resources were found within the Project Location.
- No effects to archaeological or heritage resources are anticipated as a result of the Project.

## Water Resources

- Waterbodies were identified at and within 120 m of the Project Location.
- Further assessment to document existing conditions and assess potential impacts to waterbodies will be completed this fall.
- Groundwater investigations and/or monitoring requirements will be verified during the REA process.
- The project will be located, designed, constructed and operated in a way that protects water resources.

Further details on potential environmental effects are available in the draft Project Description Report, accessible on the project website (<http://www.edf-en.ca/projects/barlow-solar-energy-centre1/>)



# COST EFFECTIVE & COMPETITIVE PRICING

## Cost Effective

Solar-generated electricity is becoming more and more competitive with traditional sources of electricity.

Solar contracts offered in 2016 (avg. price \$0.157/kWh)

Cheaper than current Ontario residential peak price (~\$0.18/kWh) and cheaper than hydro power contracts offered in 2016 (avg price of \$0.176/kWh)

## Predictable Pricing

Price paid for solar electricity is determined at the time of contract award and will not increase over its 20 year term.

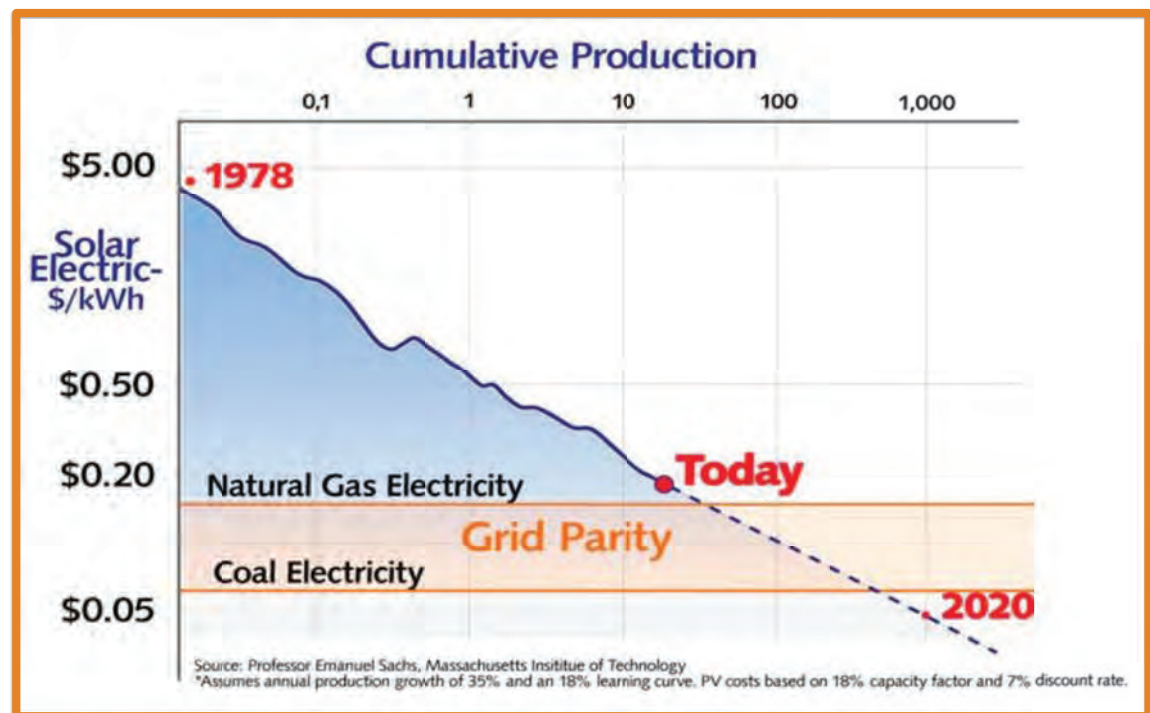

# LOCAL ECONOMIC BENEFITS

EDF EN Canada values the long-term benefits of working with the local community. We have entered into a **Community Benefit Agreement** that will contribute **\$400 000** to the **Township of South Stormont** over the life of the project.



Funds will allow community to support local initiatives such as:  
**INFRASTRUCTURE IMPROVEMENTS • RECREATIONAL FACILITIES • ENVIRONMENTAL  
PROJECTS • EDUCATIONAL PROGRAMS**



## MUNICIPAL AND LOCAL COMMUNITY BENEFITS

- **\$20,000 per year Community Benefit Agreement**  
Contributing funds to the Township of South Stormont;
- **Additional Estimated \$20,000 per year in property tax revenues**

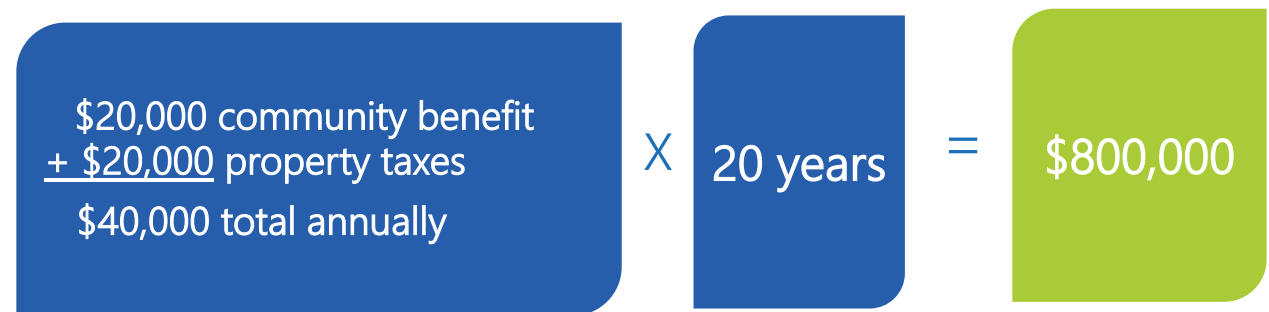
$$\begin{array}{l} \$20,000 \text{ community benefit} \\ + \$20,000 \text{ property taxes} \\ \hline \$40,000 \text{ total annually} \end{array} \times 20 \text{ years} = \$800,000$$

- **Construction jobs**  
About 100 construction jobs anticipated at the peak of construction;
- **Long-term operator positions**  
Possible full-time position within the local community to support and service the facility;
- **Local investment**  
Significant investments into the local economy during the development, construction and operation phases of the Project.

# PROJECT TIMELINE

## Project Timeline

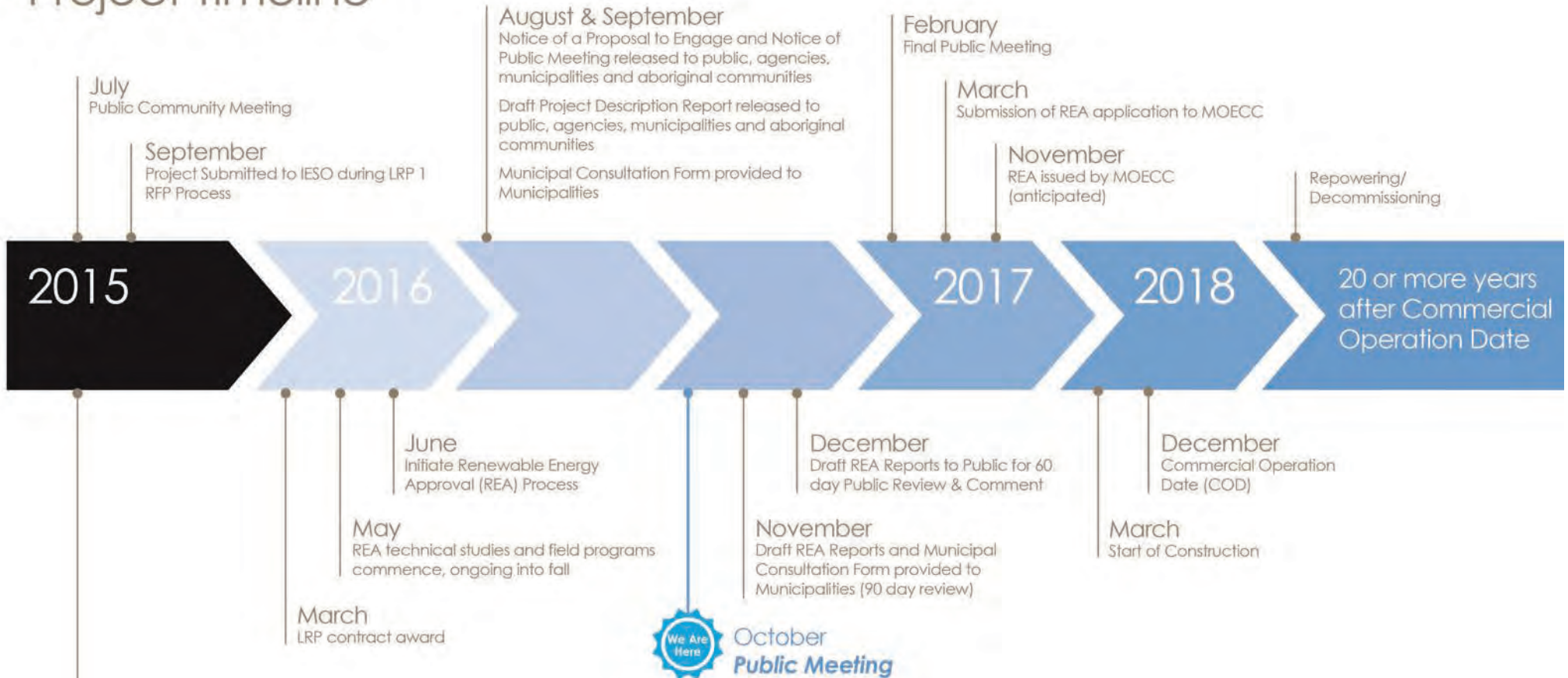

*Ongoing consultation with municipal staff, landowners, aboriginal communities, government agencies, special interest groups and members of the community.*

# WHY SOLAR MAKES SENSE

By 2020 solar will:



Produce approximately **1% of electricity** generation in Canada;



Employ a labour force of approx. **10,000 people/yr;**



Displace approx. **1.5 million tonnes** of greenhouse gas (GHG) emissions per year, the equivalent of removing **250,000 cars and trucks** off the road each year.

Source: CanSIA  
[http://cansia.ca/sites/default/files/cansia\\_roadmap\\_2020\\_final.pdf](http://cansia.ca/sites/default/files/cansia_roadmap_2020_final.pdf)

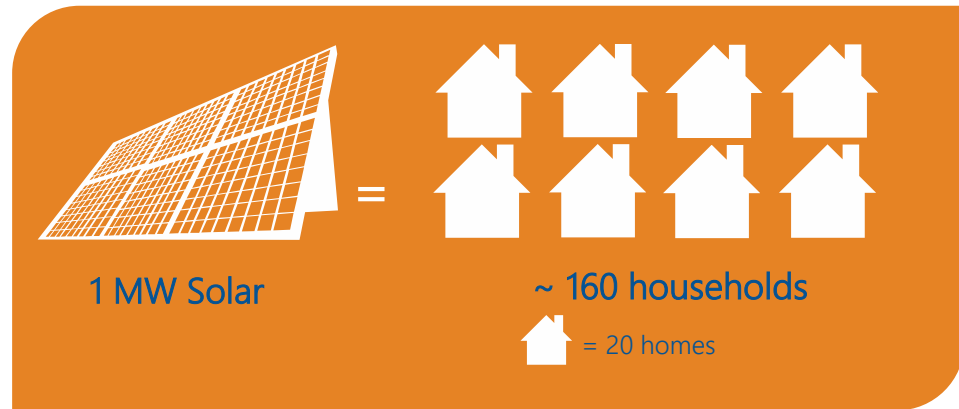

## Reduce dependence of fossil fuel

Solar energy reduces the dependence on other forms of electricity generation like natural gas and diesel that draw upon finite resources that contribute to greenhouse gas emissions.

## Supply aligns with Demand

Solar panels produce electricity to Ontario customers at times during the day when power is most needed.

## Clean energy

Solar energy emits no greenhouse gas or CO<sub>2</sub> to the air or ground during operation; water is not used for operation.



# LOCAL ECONOMIC BENEFITS

## ■ Direct benefits

Surveying

Civil engineering

Mechanical work

Electrical work

Road construction

Transportation equipment

Earthwork activities

Maintenance of vehicle fleet

Maintenance paths

Snow removal

Other related services



## ■ Indirect benefits

Meals and accommodation for construction personnel

Products, services and supplies

# POWERING PROGRESS WITH COMMUNITY PARTNERS



"Our community is very proud to be a part of such an important renewable energy project. There are tremendous economic benefits to our community including the more than 350 jobs that were created during construction and another 20 permanent operations and maintenance jobs."

*Kym Nichols,  
Mayor of Carmangay, AB*

Blackspring Ridge Wind Project (300 MW)

"EDF EN Canada has established an open and honest communication process. They shared with us their plans and have delivered exactly on their promise. This is the key to success."

*Jeannot Lachance and Michel Polin,  
Mayors of Saint-Robert-Bellarmin, QC*

Saint-Robert-Bellarmin Wind Project (80 MW)  
Le Granit Wind Project (24,6 MW)



"I consider the work done for this wind project to always have respected the important values of the MRC du Granit. Moreover, respecting the vision of the MRC, EDF EN Canada was able to put the citizens and the environment at the heart of their priorities in the development and construction of this valuable wind project."

*Maurice Bernier,  
Prefect of Granit MRC, QC (2005-2014)*

Le Granit Wind Project (24,6 MW)

# VISUAL IMPACTS AND SOUND

## Visual Impacts

The solar panels are designed to absorb light to convert it into energy, rather than reflect it. This means there will be minimal visual impact caused by glare.



## Sound

The solar panels do not emit any sound. However, the inverters (which convert electricity from direct current to alternating current electricity) and the transformers (which increase the voltage of the electricity to accommodate the local distribution grid) do emit some sound.

As part of our project design, we must meet the Provincial noise regulations that limit the noise at neighboring homes to 40 decibels (equivalent to a quiet room) measured at the outside of a home.

**A COMPARISON OF SOUND PRESSURE AND SOUND PRESSURE LEVEL**

Sound Pressure, Pa	Sound Pressure Level, dB
20	120
10	110
5	100
2	90
1	80
0,5	70
0,2	60
0,1	50
0,05	40
0,02	30
0,01	20
0,005	10
0,002	0
0,001	
0,0005	
0,0002	
0,0001	
0,00005	
0,00002	

Rock-n-Roll Band	Pneumatic Chipper (at 5 ft.)
Power Lawn Mower (at operator's ear)	Textile Loom
Milling Machine (at 4 ft.)	Newspaper Press
Garbage Disposal (at 3 ft.)	Diesel Truck 40 mph (at 50 ft.)
Vacuum Cleaner	Passenger Car 50 mph (at 50 ft.)
Air Conditioning Window Unit (at 25 ft.)	Conversation (at 3 ft.)
	Quiet Room

Source: Canadian Centre for Occupational Health and Safety, OSH Answers Fact Sheet  
[http://www.ccohs.ca/oshanswers/phys\\_agents/noise\\_basic.html](http://www.ccohs.ca/oshanswers/phys_agents/noise_basic.html)



**WE WANT  
TO HEAR  
FROM YOU!**

Please share your questions and comments with us by filling out a questionnaire. Feel free to take extra questionnaires with you and share them with your friends and family.

Copies of the display boards from this Public Meeting and the Draft Project Description Report are available on the website.

To learn more about the project proposal, public meeting, or to communicate your interests please contact us!

[BarlowSolar@edf-en.ca](mailto:BarlowSolar@edf-en.ca)

1-844-55-EDF-EN

Website: [www.edf-en.ca/projects/project\\_display/barlow-solar-energy-centre1](http://www.edf-en.ca/projects/project_display/barlow-solar-energy-centre1)

**Fabiola Oribe**, Associate Project Developer and Stakeholder Relations

Barlow Energy Centre Limited Partnership

53 Jarvis Street, Ste. 300, Toronto, ON M5C 2H2

Phone Number: 877.697.9997 (ext. 4146)



**WELCOME!**

Thank you for attending the Second Public Meeting Under the Renewable Energy Approval (REA) Process for the **Barlow Solar Energy Centre!**

We are happy to meet with you again to share new information about this clean, **renewable energy** project. Today's intent is to present the draft reports of studies conducted during the past few months and keep collecting additional input from the community to be considered for integration into our design.

Please review the display boards and feel free to ask us any questions you may have.

**We want to hear from you!**

Please complete a comment form to share your feedback! If you would like to be added to the Project mailing list, please sign up at the front desk.

# EDF EN CANADA

## 1 680 MW

Put into Service,  
Under Construction,  
or In Development

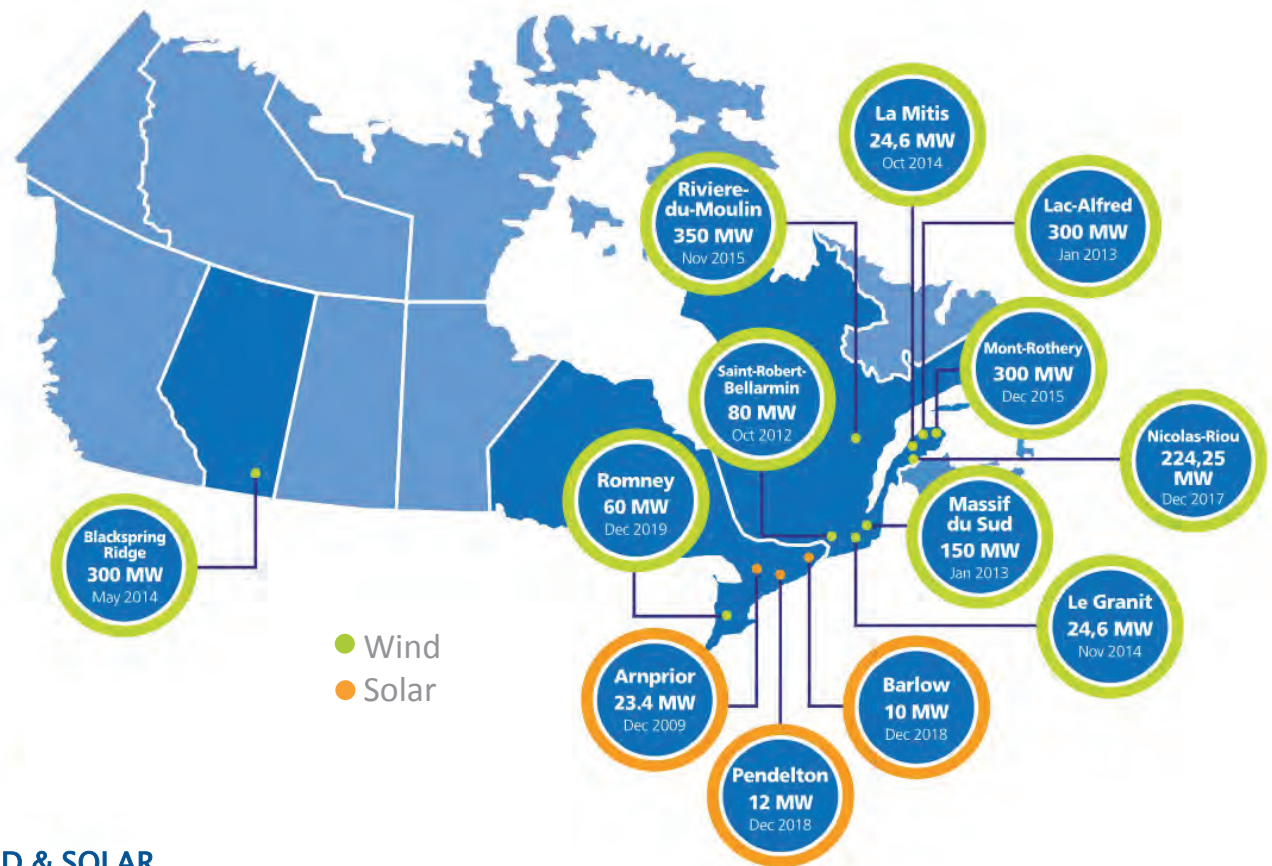

### WIND & SOLAR

**1 374 MW** (350 000 homes) Commissioned Capacity

**224 MW** (54 900 homes) Under Construction

**82 MW** (20 100 homes) In Development

### OPERATIONS & MAINTENANCE

**1 061 MW** Wind

**516 MW** Solar

> \$3.5 billion invested  
in Canada since 2008



## PROJECT OVERVIEW

**PROJECT NAME:** Barlow Solar Energy Centre

**PROJECT OWNERS:** EDF EN Canada and the Algonquins of Pikwàkanagàn First Nation

**HOST MUNICIPALITIES:** Township of South Stormont and City of Cornwall

**RENEWABLE FUEL:** Non-Rooftop Solar

**CONTRACT CAPACITY:** 10 MWac

### PROPOSED CONNECTION POINT

Located within the City of Cornwall, on an existing distribution line along Power Dam Drive, about 600 metres east of the Project Location near the intersection of Cornwall Centre Road and Power Dam Drive.

### CONNECTION LINE

The Connection Line will run approximately 900 m eastward along Cornwall Centre Road, using the road allowance belonging to the City of Cornwall, from the Project Location to the Connection Point.

# PROJECT LOCATION

Located in the Township of South Stormont and the City of Cornwall.

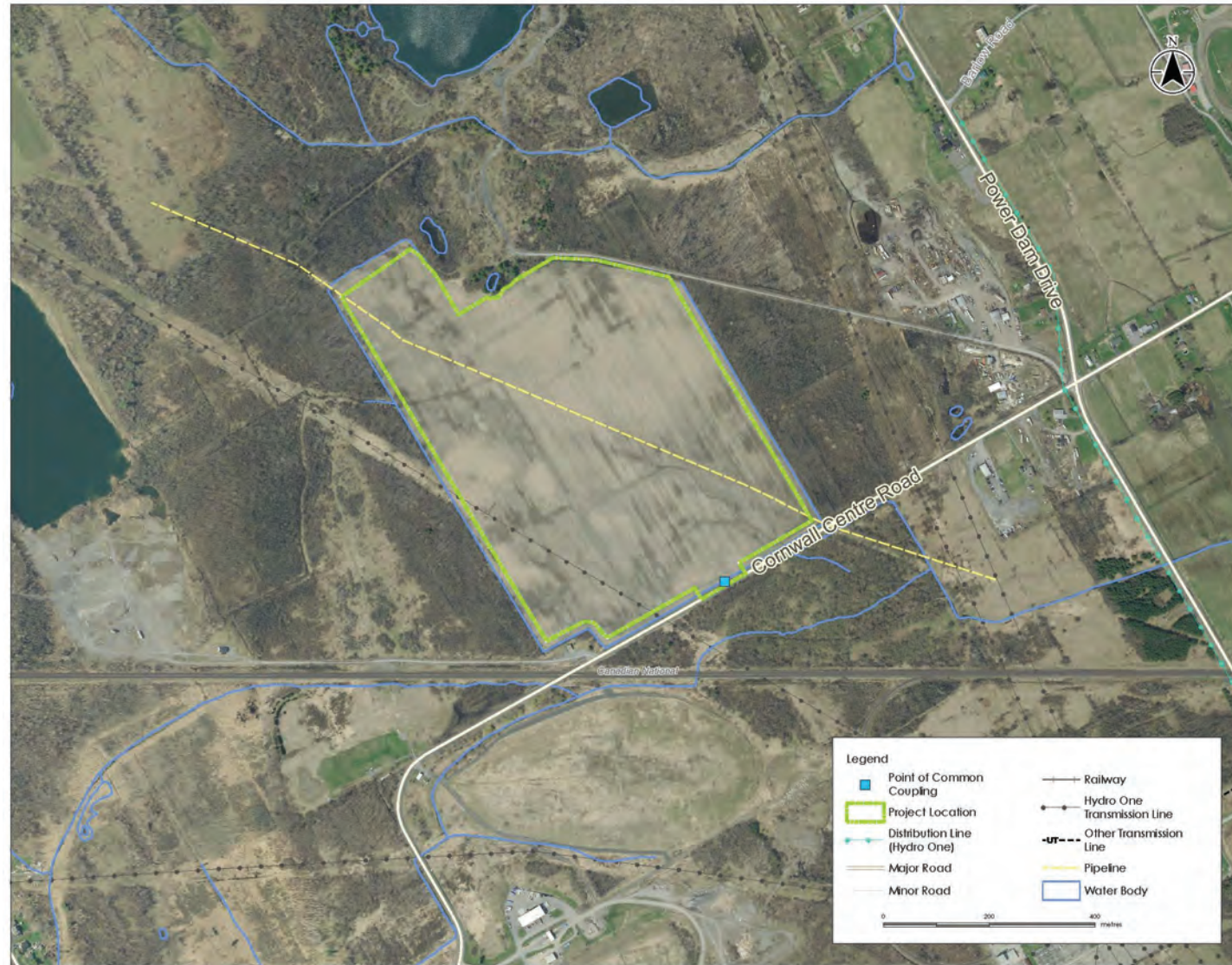



# BEING A GOOD NEIGHBOUR

When it comes to environmental benefits, solar can offer more than clean electricity



EDF EN Canada, working closely with local stakeholders, took advantage of the wild flowers and clover that typically grow within a solar park and installed beehives in the vicinity of Arnprior Solar park to enhance the biodiversity of the project by producing honey.

To further increase solar honey production, more hives are planned for 2017. Collection of more than 350 jars are anticipated. The honey produced is given as a gift to company employees, partners and project stakeholders.

**SUNNY & HONEY**  
**100%**  
**ARNPRIOR SOLAR**  
**HONEY**

Beehive installed by EDF EN Canada at Arnprior Solar in Ottawa area made possible by planting vegetation such as clover beneath solar panels.



# PROJECT TIMELINE

## Project Timeline

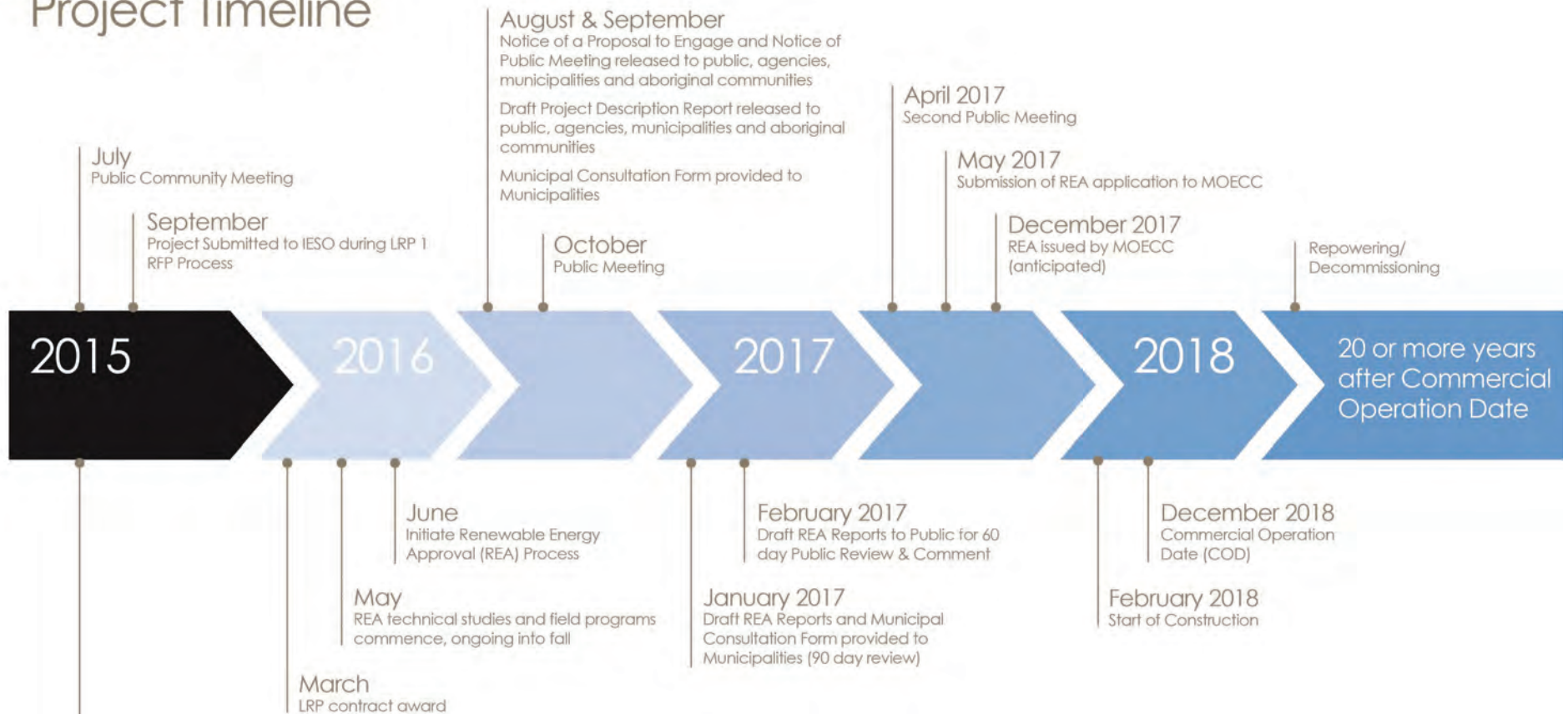

*Ongoing consultation with municipal staff, landowners, aboriginal communities, government agencies, special interest groups and members of the community.*

# THE RENEWABLE ENERGY APPROVAL PROCESS

## Overview of Renewable Energy Approval Process

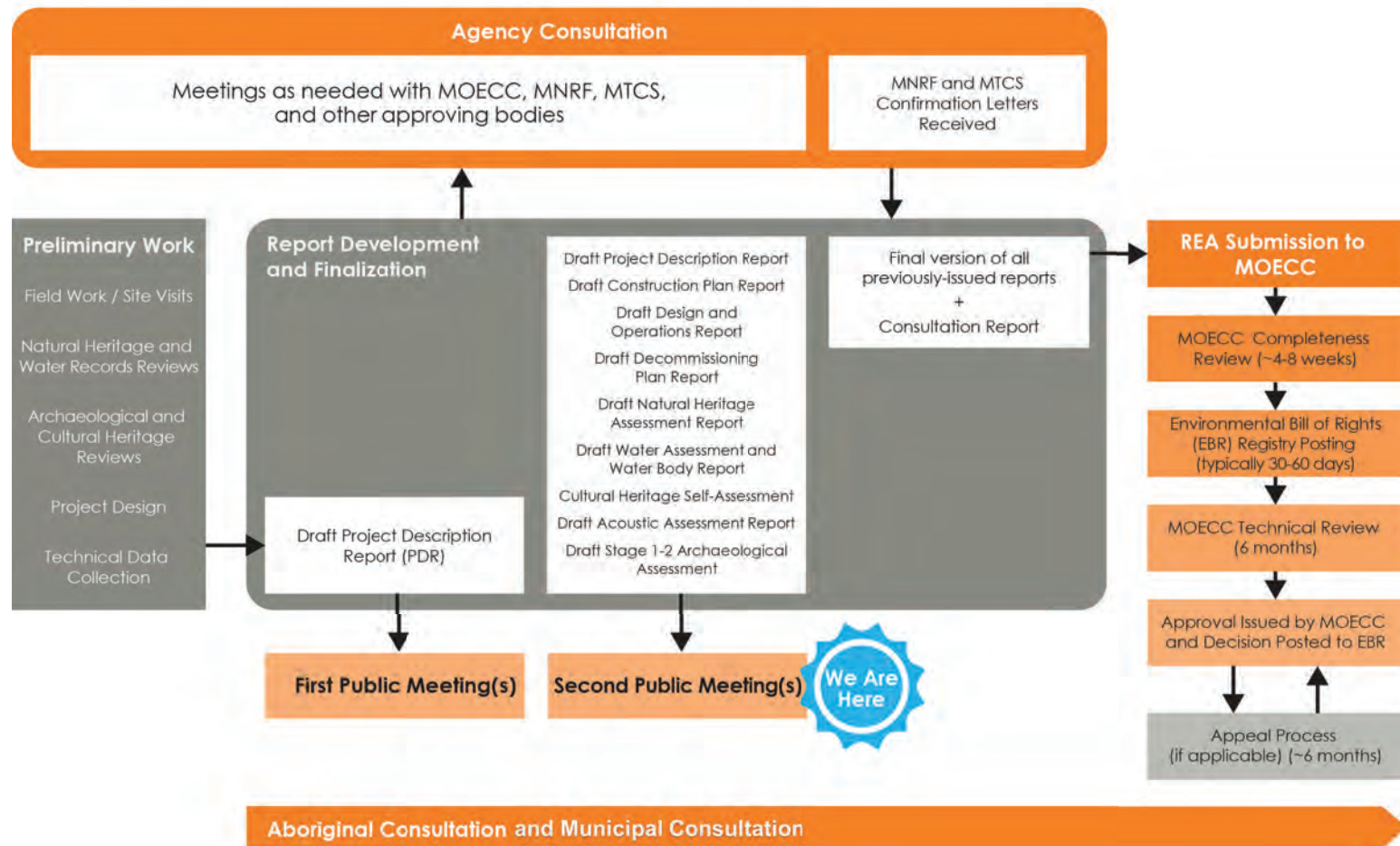

- Issued under Ontario Regulation 359/09 under the *Environmental Protection Act*.
- Stringent environmental approval process that needs to be satisfied before construction.
- Specifies how the Project will be designed, built, operated and decommissioned so that the environment is protected.

# RENEWABLE ENERGY APPROVAL REPORTS CONSTRUCTION PLAN

- The **Construction Plan Report** includes a summary of project construction and installation activities, potential construction environmental effects, and any necessary mitigation and monitoring measures.
- The Report addresses the construction period of the Project, scheduled to be Q1 2018 through to the end of Q4 2018.
- Environmental components addressed in the **Construction Plan Report** include:
  - ✓ Cultural Heritage and Archaeological Resources
  - ✓ Natural Heritage Features
  - ✓ Water Bodies & Aquatic Resources
  - ✓ Air Quality & Environmental Noise
  - ✓ Land Use and Socio-Economic Resources
  - ✓ Existing Utilities and Infrastructure
  - ✓ Waste Material Disposal & Accidental Spills

## Report Summary

The Project has been sited in a manner that will minimize environmental effects. Construction of the Project can be completed using standard, well-known techniques to prevent, manage or mitigate potential effects to the environment.

- Before construction, a **Construction Environmental Management Plan (CEMP)** will be developed. The Project owner and its contractors will implement the **CEMP** to protect the environment and ensure compliance with the Renewable Energy Approval. As appropriate, the **CEMP** will also include procedures and plans for the following:

- Traffic Management Plan
- Waste Management Plan
- Emergency Response and Communications Plan
- Complaint Response Protocol

- During construction, a **Construction Environmental Effects Monitoring Plan (CEEMP)** will be implemented to assess the impacts of construction activities on environmental features and check that mitigation measures and contingency planning are effectively implemented. This will include trained, on site personnel responsible for monitoring implementation of the **CEEMP**.

# RENEWABLE ENERGY APPROVAL REPORTS DESIGN AND OPERATIONS

- The Design and Operations Report describes the operational details of the project, its site plan, potential operational environmental effects, and any necessary mitigation and monitoring measures.
- The Report addresses the operations period of the Project, scheduled for a 20-year period, beginning in Q4 2018.
- Environmental components addressed in the Design and Operations Report are similar to the Construction Plan Report.
- In addition, the Design and Operations Report includes a site plan, facility design plan, and a facility operations plan.

## Report Summary

The Project has been designed and will be operated in a manner that will minimize environmental effects. Operation of the Project will include continuous remote monitoring, and regular maintenance and inspection. These activities can be completed in a manner that will prevent, manage or mitigate potential effects to the environment.

- Prior to operation, an **Emergency Response and Communications Plan** will be developed for use by Project employees. The Plan will establish and maintain emergency procedures required to effectively deal with an emergency situation and minimize potential effects. The Plan will be used throughout the operational life stage of the Project.
- During operation, an **Environmental Effects Monitoring Plan (EEMP)** will be implemented to ensure mitigation measures and contingency planning are effectively implemented. The plan will describe activities during operation and how monitoring and contingency measures described in the **Design and Operations Report** will be implemented. This may include things such as:

- Monitoring ditches and culverts to ensure proper site drainage
- Vegetation management and monitoring
- Noise monitoring, if required



# RENEWABLE ENERGY APPROVAL REPORTS DECOMMISSIONING

- The **Decommissioning Plan Report (DPR)** provides a summary of project decommissioning activities, potential decommissioning environmental effects and any necessary mitigation and monitoring measures.
- The Project is expected to have an operational lifespan of 20 or more years, beginning in Q4 2018.
- At the end of the Project lifespan, it may be decommissioned or “repowered” with updated technology and continue to generate renewable energy.
- The **DPR** has assumed that the land will be returned to its current agricultural use. However, the **DPR** will be updated in advance of decommissioning to reflect the actual conditions, plans for the site and regulatory requirements in effect at that future time.

## Report Summary

The Project can be decommissioned in a manner that will minimize environmental effects and restore the land to its current, pre-Project use. Decommissioning of the Project essentially reverses the construction sequence and can be completed using standard, well-known techniques to prevent, manage or mitigate potential effects to the environment.

Decommissioning of the project would generally consist of removal of all above-ground Project equipment, including:

- Solar panels, racking and inverter stations
- Substation, collection system, storage infrastructure and perimeter fencing
- Piles, foundations and buried cables at least one meter below surface

- A Rehabilitation plan would be developed to guide restoration of the site to agricultural use, or to a state suitable for the use planned at that time.
- Environmental mitigation and monitoring requirements would be defined to ensure protection of nearby environmental features.
- **Emergency Response and Communications Plans** that are relevant to decommissioning will be brought forward from the operations phase of the Project, such as procedures to address accidental spills and releases, waste management, and erosion and sediment control. This Plan will also remain in effect during decommissioning.

# RENEWABLE ENERGY APPROVAL REPORTS ACCOUSTIC ASSESSMENT

- Solar photovoltaic panels do not produce any acoustic emissions.
- However, some acoustic emissions are generated when the facility is operating (during daylight hours) by the four (4) inverters and inverter step-up transformers, and one (1) main power transformer.
- An **Acoustic Assessment** was completed for the Project to ensure it is designed in a manner that keeps acoustic emissions below 40 dB at applicable neighboring receptors, in compliance with Ministry of Environment and Climate Change (MOECC) requirements.
- This **Acoustic Assessment Report** was prepared based on MOECC requirements described in the following documents:
  - ✓ NPC-300, Environmental Noise Guideline.
  - ✓ Basic Comprehensive Certificates of Approval, User Guide v2.0, Appendix A, "Supporting Information to be Submitted for an Acoustic Assessment Report or Vibration Assessment Report Required by a Basic Comprehensive C of A", April 2004.

- The **Acoustic Assessment** used a very conservative scenario where all equipment is operating at maximum capacity and no additional mitigation is incorporated. Also, any acoustic shielding by solar panels was not considered in the assessment.
- All receptors (including vacant lots where a receptor could be built) within one kilometer of the Project Location were considered.

## Report Summary

The Project design meets MOECC requirements for a Class 3 solar facility.

- The analysis demonstrated that the Project acoustic emissions comply with MOECC limits at all receptors within 1 km of the Project, without the need for any additional mitigation measures.
- Once operational, a noise audit will be completed to ensure the Project is operating in compliance with the Renewable Energy Approval. If the audit identifies higher acoustic emissions then mitigation measures will be implemented.

The Project Location is situated within an active agricultural area and not within a natural feature.

Natural heritage features located within 50 m of the Project Location (i.e., Zone of Influence) were assessed for significance.

Field surveys included:

- Vegetation Community & Vascular Plants Assessment
- Wetland & Woodland Confirmation and Delineation (through Ecological Land Classification and Ontario Wetland Evaluation Survey Methods)
- Wildlife & Wildlife Habitat Assessment Surveys

No significant features were found within the Project Location Boundary. Five wetland and four woodland features are located within 50 m of the Project Location and are considered significant.

The report is currently under review with the Ministry of Natural Resources & Forestry.

## Mitigation Measures

All Project components are sited outside wetland and woodland feature boundaries. Some standard best management practices to be applied to all construction activities include:

- No development permitted within the boundaries of significant wetlands or woodlands
- Edge of the work zone will be flagged/staked prior to construction
- Silt barriers will be erected along the edge of wetland/woodland boundaries where within 30 m of Project Location
- Environmental inspector(s) will monitor construction
- Maintenance activities, vehicle refueling or washing, and storage of chemicals and equipment will occur in properly protected and sealed areas located more than 30 m from significant wetlands/woodlands

Additional mitigation measures are listed in the [Natural Heritage Assessment & Environmental Impact Study, Construction Plan Report, and Design & Operations Report](#). The application of these mitigation measures are expected to address negative environmental effects of construction, operation and decommissioning of the Project on the natural heritage features located within the Project Location/Zone of Influence and their associated ecological functions.



- Field surveys included:
  - ✓ Investigation of water features mapped within the Project Location and within 120 m of the Project Location
  - ✓ Classification of water features as “REA-defined Water Bodies” if they met the specific definition in O. Reg. 359/09
  - ✓ General fish habitat assessment
- Five water bodies were confirmed during site investigations. One water body crosses the Project Location on the north side of Cornwall Centre Road.
- The records review suggested the presence of 2 water bodies in the southern and northern portion of the Project Location. Based on the findings of the water assessment, these 2 features are not considered “REA-defined Water Bodies”.
- Groundwater investigations and/or monitoring requirements will be verified during the REA process.

## Mitigation Measures

Some standard best management practices to be applied to all construction activities include:

- Complete in-water work within MNR timing windows to protect local fish populations during their spawning and egg incubation periods (i.e., no in-water work between March 15 and July 15)
- Operate and store materials and equipment used for the purpose of site preparation and Project construction in a manner that reduces the risk of the entry of deleterious substances into surface waters
- Implement erosion and sediment control measures prior to construction and maintain measures during the construction phase to reduce the risk of the entry of sediment into the water

Mitigation measures will be further determined through consultation with the municipality and the DFO, and are dependent on project details (i.e., culvert size and construction methods).

Additional mitigation measures are listed in the [Water Assessment & Water Body Report](#), [Construction Plan Report](#), and [Design & Operations Report](#). Based on the current Project layout and proposed environmental mitigation measures, no net effects to water bodies are expected to occur as a result of the Project.

## Stage 1 & 2 Archaeological Assessment Report

- Heritage and archaeological studies were completed according to the requirements of the Ministry of Tourism, Culture and Sport (MTCS).
- No built resources were identified within the Project Location and no cultural heritage landscapes or protected properties were identified in, or adjacent to, the Project Location.

## Consideration of Potential for Heritage Resources

- Based on the [Stage 1 Archaeological Assessment](#), archaeological potential for Aboriginal and historic Euro-Canadian sites was deemed moderate to high. As such, a [Stage 2 Archaeological Assessment](#) was completed.
- No archaeological resources were found during the Stage 2 assessment of the Project Location.
- The [Stage 1 & 2 Archaeological Assessment](#) has been reviewed and accepted by the MTCS.
- No effects to archaeological or [heritage resources](#) are anticipated as a result of the Project.

## Mitigation Measures

If any artifacts, soil features, or other cultural features of note are discovered during groundwork for the Project, the following procedures shall be adhered to:

- Work in the area of the site or artifacts shall halt immediately and the general contractor notified of the discovery
- The area of the site, along with a buffer zone of 5 m (as available) shall be cordoned off using a barrier/stakes and flagging tape
- The regional archaeologist from the MTCS shall be contacted to determine the appropriate course of action
- If human remains are discovered during Project activities the following procedures shall be adhered to:

- All work shall cease in the immediate area of the discovery and the environmental inspector notified immediately
- Remains shall be covered as soon as possible
- Local police and/or coroner shall be contacted immediately

Mitigation measures are not required for built resources, cultural heritage landscapes or protected properties as none exist within or adjacent to the Project Location.



# REA STUDIES & REPORTS

All reports, with the exception of the Consultation Report, were made available in draft form for public review and comment more than 60 days prior to this Public Meeting. Reports can also be found on the website, and hard copies are available here today.

REA DOCUMENTS	SUMMARY
PROJECT SUMMARY REPORT	A summary of each of the project reports identified below
PROJECT DESCRIPTION REPORT	Outlines the project including project components, anticipated schedule, authorizations potentially required and potential environmental effects.
CONSTRUCTION PLAN REPORT	Includes a summary of project construction and installation activities, potential construction environmental effects and mitigation measures.
DESIGN AND OPERATIONS REPORT	Provides an overview of the project site plan, as well as potential operational environmental effects and mitigation. Includes discussion on emergency response and communications plan.
DECOMMISSIONING PLAN REPORT	A summary of project decommissioning activities, potential decommissioning environmental effects and mitigation measures.
STAGE 1 AND 2 ARCHAEOLOGICAL ASSESSMENT	Provides an overview of the methodology and results of the Stage 1 (desktop) and Stage 2 (field study), and outlines the potential for the existence of archaeological resources within the Project Location boundary.
NATURAL HERITAGE ASSESSMENT / ENVIRONMENTAL IMPACT STUDY	Summarizes the findings of the terrestrial background research and field studies undertaken for the project. Identifies and proposes mitigation measures for significant natural heritage features identified within and surrounding the Project Location.
WATER ASSESSMENT AND WATER BODY REPORT	Summarizes the findings of the aquatic background research and field studies undertaken for the project. Identifies and proposes mitigation measures for water bodies identified within and adjacent to the Project Location.
ACOUSTIC ASSESSMENT REPORT	Identifies receptors and the propagation of sound from the facility to predict if sound from project will be limited to 40 dB (equivalent to a quiet room), at applicable neighboring receptors.

# DRAFT SITE LAYOUT

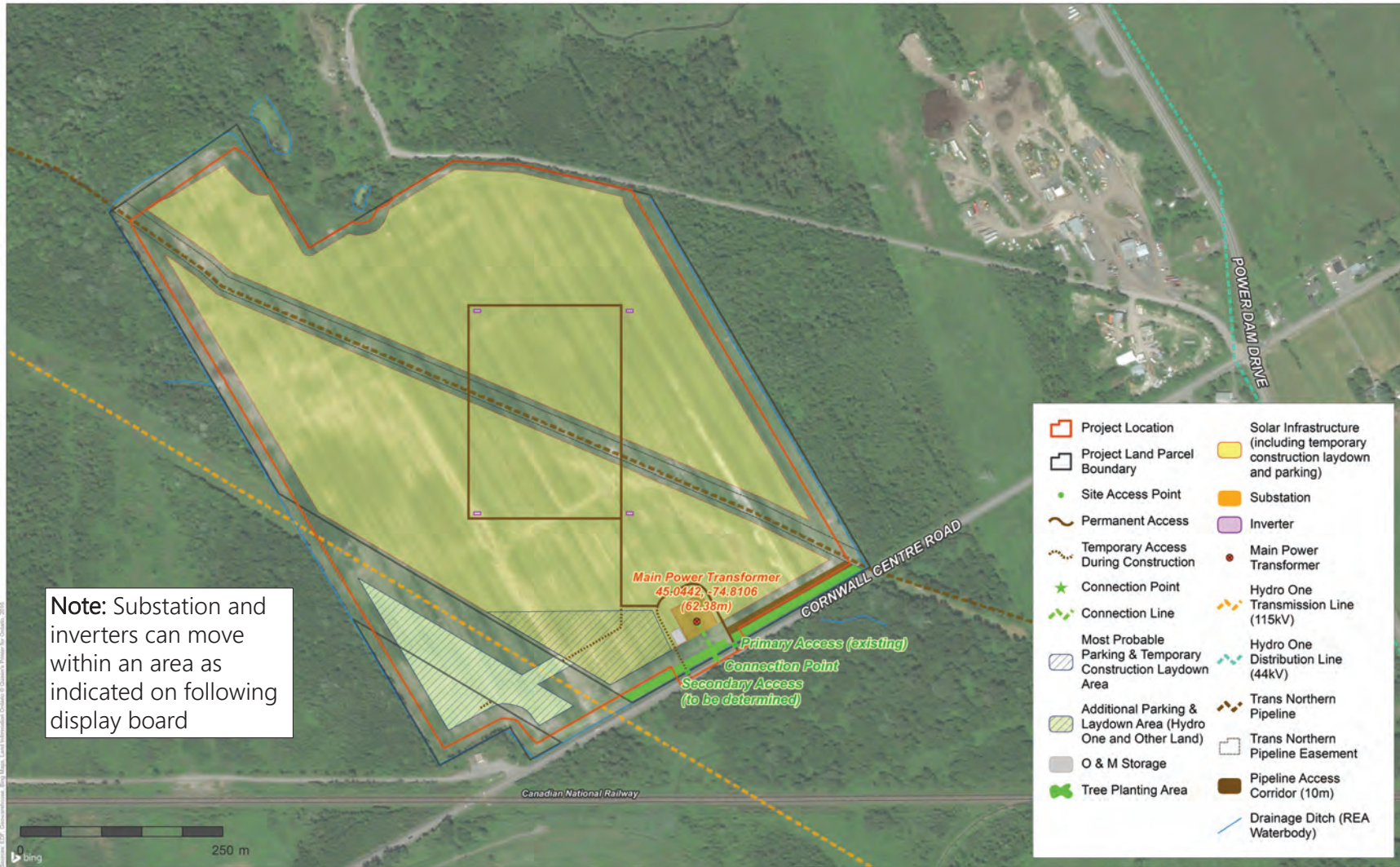

# BARLOW ENERGY CENTRE DESIGN PARAMETERS NOISE / OPERATIONAL FLEXIBILITY

- Using polygon multiple method
- Determine shapes within which noise-generating equipment can be moved around, but remain within noise guidelines at applicable receptors
- Renewable Energy Approval permit may allow flexibility to move equipment within polygons where demonstrated that noise will remain in compliance

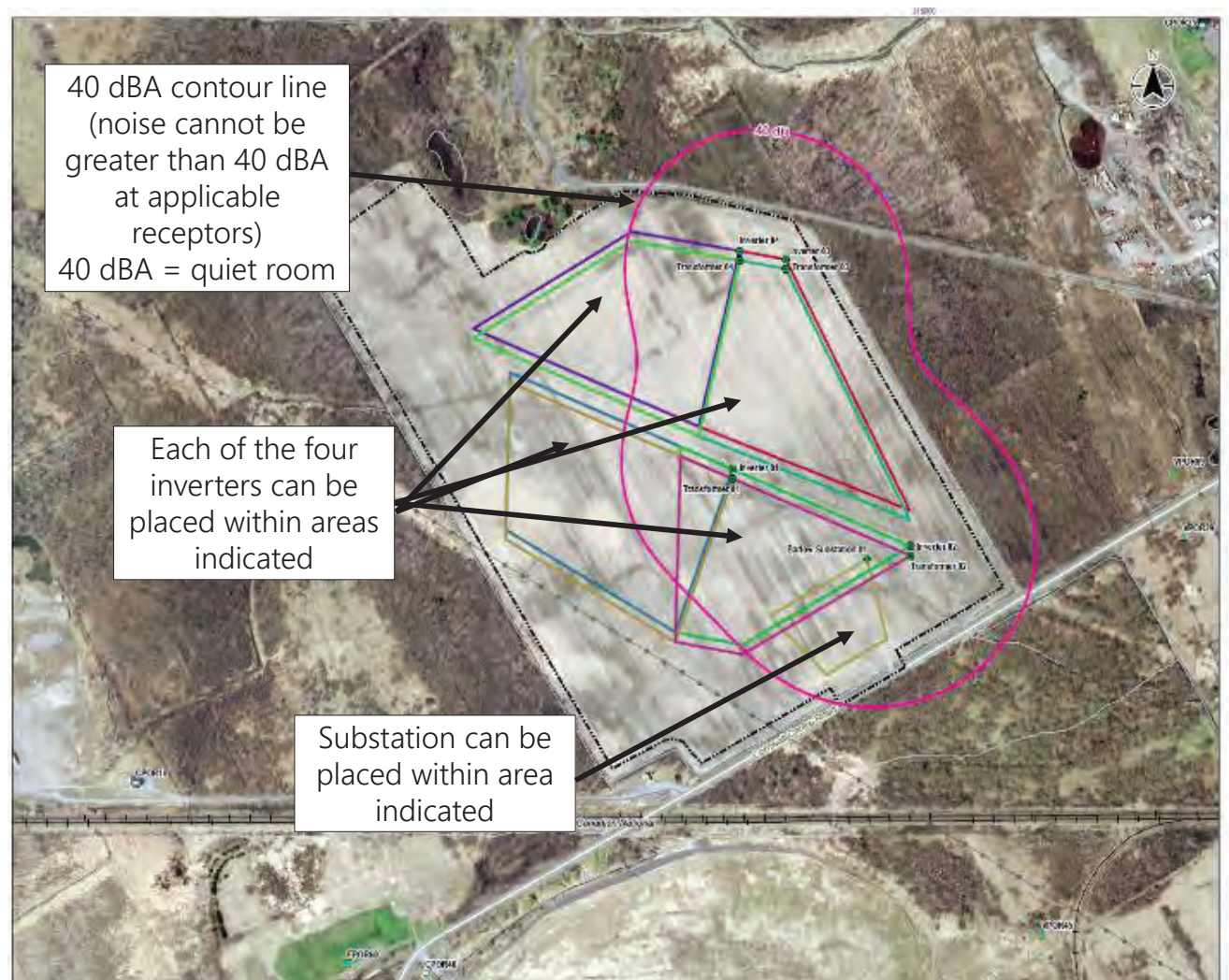



- 1.8 m high steel chain link fence topped with barbed wire around site perimeter
- Manual locking gates installed at primary entrances and possibly secondary entrance



Sample fence

## DESIGN CONSIDERATIONS – ROADS

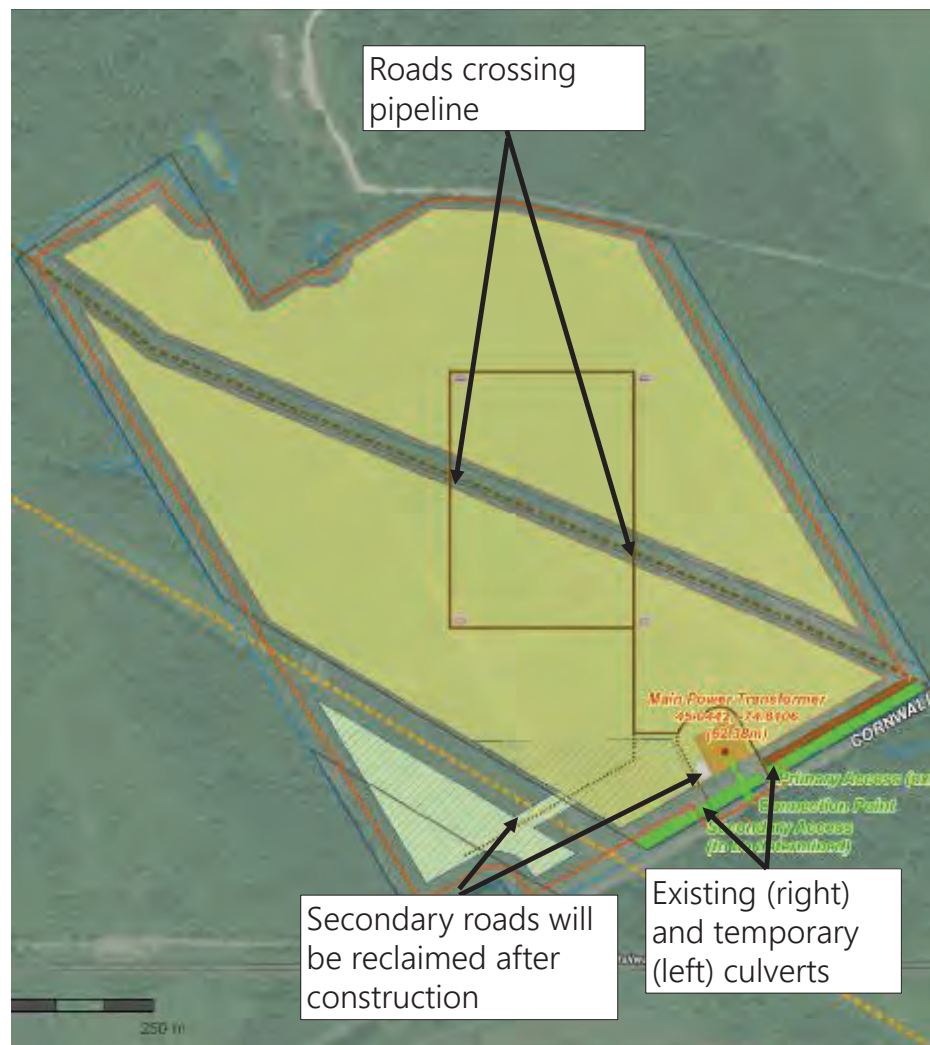

- Amount of roads to be minimized, only to access inverter/transformer skids and substation areas
- 4 m wide gravel roads with 1 m compacted shoulder on each side proposed within the site
- Temporary roads from secondary access point and temporary laydown area will be reclaimed at the end of construction
- Propose to elevate the road from Cornwall centre drive to substation to maintain access in case of flood. Roads to access inverters will be left at current grade
- New culvert and existing culvert will require in-water works (works planned between July 16 and March 14)
- Roads crossing pipeline may need to be elevated to maintain minimum height above pipeline - 1.2 metres clearance required between bottom of road and pipeline

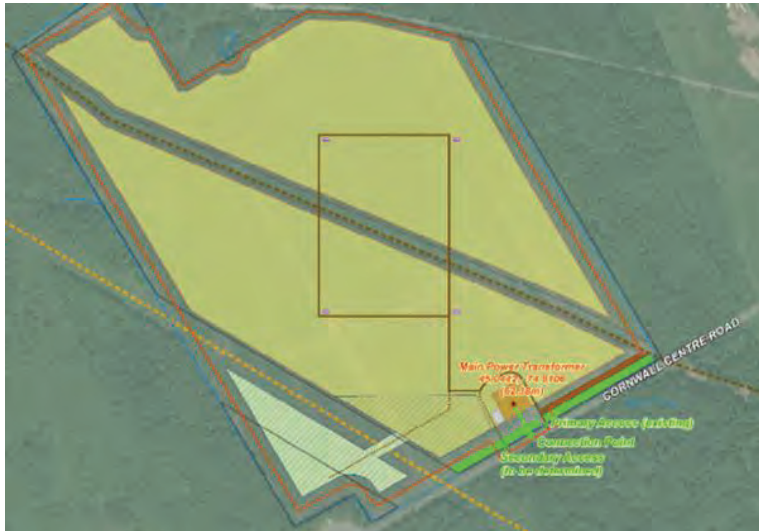

Proposed tree planting – green bar along Cornwall Centre Road  
(north of Road Right of Way and west of Pipeline Easement)



Vegetation around/beneath panels

- Plan to seed the area prior to construction to provide stable ground and prevent erosion during construction
  - ✓ Intend to consult with Raisin Region Conservation Authority for suitable seed mix
- Site not disturbed by infrastructure will be vegetated (including under solar panels)
- Following construction, trees will be planted along Cornwall Centre road (except along the pipeline easement)



- Two designs being considered
  - ✓ Fixed tilt
  - ✓ Horizontal single axis tracking (HSAT)



Example of Horizontal Single Axis Tracker in Table Position



Fixed tilt – bottom of panel > 30 cm above floodplain level

- Both mounted on piles
  - ✓ Fixed tilt lowest part of panel > 30 cm above floodplain
  - ✓ HSAT lowest part of module while in table position (i.e. flat with no east/west inclination) or electrical equipment for tracking > 30 cm above floodplain

## TRACKING SOLAR PANELS HOW DO THEY WORK?

- A **tracker** is a type of racking system that follows the sun as it arcs through the sky – ensuring the panels always face the sun.
- The **motors** may be solar powered, potentially eliminating the need for external power.
- The **panels** are mounted in rows on a north/south axis. A tracking motor is located in the middle of each row.
- **Wireless communication** between each row controls the movement of the panels and alerts operators to any errors.

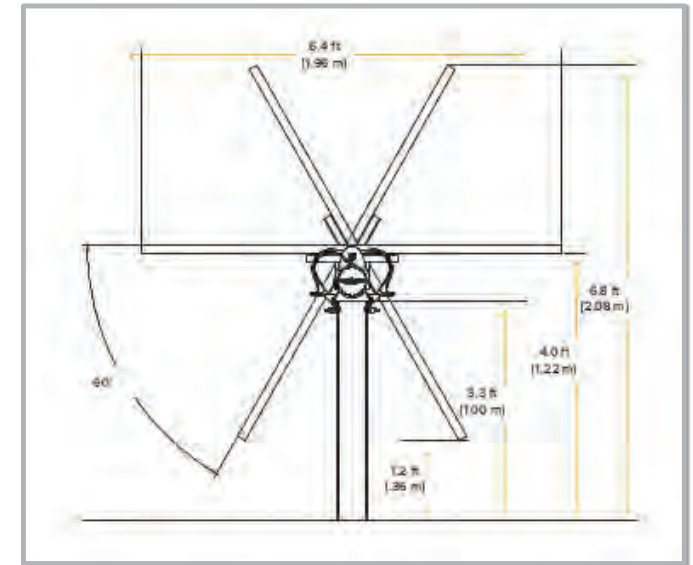

HSAT Sample Dimensions

Examples of horizontal  
single axis trackers



## BARLOW ENERGY CENTRE DESIGN PARAMETERS INVERTER / TRANSFORMER SKIDS

- Skid-mounted, floor of skid > 30 cm above floodplain
- Supported by helical pile or concrete piers
- Topsoil will be stripped, stockpiled and reused to extent possible during site landscaping



Sample Inverter/Transformer Skids



Sample substation

- Includes control building, storage containers, main power transformer
- Substation area proposed to be built up area of soil/fill/pit run gravel, roughly 25 m x 20 m. Top of mound will be > 30 cm above floodplain level
- Propose that access road to substation be elevated to maintain access vehicular access in case of flood

# SOLAR PARK EQUIPMENT



# LOCAL ECONOMIC BENEFITS

EDF EN Canada values the long-term benefits of working with the local community. We have entered into a **Community Benefit Agreement** that will contribute **\$400 000** to the **Township of South Stormont** over the life of the project.



Funds will allow community to support local initiatives such as:  
**INFRASTRUCTURE IMPROVEMENTS • RECREATIONAL FACILITIES • ENVIRONMENTAL  
PROJECTS • EDUCATIONAL PROGRAMS**



## MUNICIPAL AND LOCAL COMMUNITY BENEFITS

- **\$20,000 per year Community Benefit Agreement**  
Contributing funds to the Township of South Stormont;
- **Additional Estimated \$20,000 per year in property tax revenues**

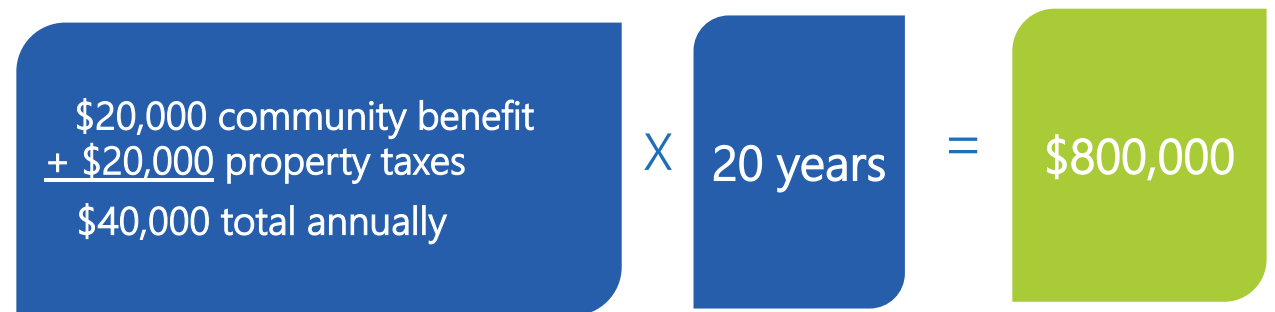
$$\begin{array}{l} \$20,000 \text{ community benefit} \\ + \$20,000 \text{ property taxes} \\ \hline \$40,000 \text{ total annually} \end{array} \times 20 \text{ years} = \$800,000$$

- **Construction jobs**  
About 100 construction jobs anticipated at the peak of construction;
- **Long-term operator positions**  
Possible full-time position within the local community to support and service the facility;
- **Local investment**  
Significant investments into the local economy during the development, construction and operation phases of the Project.

# LOCAL ECONOMIC BENEFITS

## ■ Direct benefits

Surveying

Civil engineering

Mechanical work

Electrical work

Road construction

Transportation equipment

Earthwork activities

Maintenance of vehicle fleet

Maintenance paths

Snow removal

Other related services



## ■ Indirect benefits

Meals and accommodation for construction personnel

Products, services and supplies



# VISUAL IMPACTS AND SOUND

## Visual Impacts

The solar panels are designed to absorb light to convert it into energy, rather than reflect it. This means there will be minimal visual impact caused by glare.



## Sound

The solar panels do not emit any sound. However, the inverters (which convert electricity from direct current to alternating current electricity) and the transformers (which increase the voltage of the electricity to accommodate the local distribution grid) do emit some sound.

As part of our project design, we must meet the Provincial noise regulations that limit the noise at neighboring homes to 40 decibels (equivalent to a quiet room) measured at the outside of a home.

**A COMPARISON OF SOUND PRESSURE AND SOUND PRESSURE LEVEL**

Sound Pressure, Pa	Sound Pressure Level, dB
20	120
10	110
5	100
2	90
1	80
0,5	70
0,2	60
0,1	50
0,05	40
0,02	30
0,01	20
0,005	10
0,002	0
0,001	
0,0005	
0,0002	
0,0001	
0,00005	
0,00002	

Rock-n-Roll Band	Pneumatic Chipper (at 5 ft.)
Power Lawn Mower (at operator's ear)	Textile Loom
Milling Machine (at 4 ft.)	Newspaper Press
Garbage Disposal (at 3 ft.)	Diesel Truck 40 mph (at 50 ft.)
Vacuum Cleaner	Passenger Car 50 mph (at 50 ft.)
Air Conditioning Window Unit (at 25 ft.)	Conversation (at 3 ft.)
	Quiet Room

Source: Canadian Centre for Occupational Health and Safety, OSH Answers Fact Sheet  
[http://www.ccohs.ca/oshanswers/phys\\_agents/noise\\_basic.html](http://www.ccohs.ca/oshanswers/phys_agents/noise_basic.html)



**WE WANT  
TO HEAR  
FROM YOU!**

Please share your questions and comments with us by filling out a questionnaire. Feel free to take extra questionnaires with you and share them with your friends and family.

Copies of the display boards from this Public Meeting, Project Newsletters and the Draft Renewable Energy Approval Reports are available on the website.

To learn more about the project proposal, public meeting, or to communicate your interests please contact us!

[BarlowSolar@edf-en.ca](mailto:BarlowSolar@edf-en.ca)

1-844-55-EDF-EN

Website: [www.edf-en.ca/projects/project\\_display/barlow-solar-energy-centre1](http://www.edf-en.ca/projects/project_display/barlow-solar-energy-centre1)

**Fabiola Oribe**, Associate Project Developer and Stakeholder Relations

Barlow Energy Centre Limited Partnership

53 Jarvis Street, Ste. 300, Toronto, ON M5C 2H2

Phone Number: 877.697.9997 (ext. 4146)

# APPENDIX C COMMENT AND RESPONSE TABLE

Record	Type	Date	Subject Matter	Project Response	Date of Response	Follow-up
<b>PUBLIC</b>						
1	Public Meeting Questionnaire	Oct 5, 2016	Main reason for attending is because is interested to understanding project. The public meeting meet information needs, and it was very well presented. Believes that the key issues that need to be addressed in the public consultation is the communication. Agrees with the Barlow Solar Energy Centre as currently proposed by Barlow Energy Center LP.	N/A	N/A	N/A
2	Public Meeting Questionnaire	Oct 5, 2016	Main reason for attending is because he's municipal councillor. The public meeting meet his information needs and he was already aware of must of the info. He believes that the key issues that need to be addressed in the public consultations are the construction operation and decommissioning. He agrees with the Barlow Solar Energy Centre as currently proposed by Barlow Energy Center LP.  Concerning his question or information request:  - Who is responsible for addressing repairs to damage infrastructure from the construction of the project.	Response provided verbally at the Public Meeting.  Proponent is engaging with City of Cornwall to implement a roadway damage permit (i.e. agreement to repair roads should they be deteriorated as part of the project).	Oct 5, 2016	N/A

Record	Type	Date	Subject Matter	Project Response	Date of Response	Follow-up
3	Public Meeting Questionnaire	Oct 5, 2016	<p>His main reason for attending is his concern over development and potential problem with his airfield (Cornwall Aeromodellers.com).</p> <p>The public meeting met his information needs. He believed that the keys issues that need to be addressed during public consultation is fixed resale cost of electricity that is not applied to local people.</p> <p>He wants us to consider radio interference with model planes flying from his local field (next to solar farm) height and location of radio tower.</p> <p>He agrees with the Barlow Solar Energy Centre as currently proposed by Barlow Energy Center LP.</p>	Response provided verbally at the Public Meeting.	Oct 5, 2016	See # 6
4	Public Meeting Questionnaire	Oct 6, 2016	The public meeting met all the information he needed. He believes that the key issues that need to be addressed in the public consultation are the environment concerns and the costs. His or his employer might be useful during the construction or during the operation of the solar farm. He completely agrees with the Barlow Solar Energy Centre as currently proposed by Barlow Energy Center LP.	N/A	N/A	N/A
5	Public Meeting Questionnaire	Oct 6, 2016	Attended to keep updated about environmental projects being installed in this part of Ontario. See if there is opposition. Noted few public participants, but that all questions were truthfully answered. A key issue is to show us that battery storage is progressing and that prices for electric power are going to stop expanding exponentially. Key information -	N/A	N/A	N/A

Record	Type	Date	Subject Matter	Project Response	Date of Response	Follow-up
			City dump is across the road. They wastefully burn off methane gas. Could potentially be put to better use. He agrees with the Barlow Solar Energy Centre as currently proposed by Barlow Energy Center LP.			
6	Meeting	November 11, 2016	Follow up meeting with Cornwall Aero Modellers. They agreed that presence of Barlow Energy Centre adjacent to club's flying area will not impose adverse impacts to the group, as they do not typically fly over the project area. The transmission line separating the club's flight area and the project is visible from the ground where the pilots fly their aircraft.	N/A	N/A	N/A
7	Public Meeting Questionnaire	April 24, 2017	Cornwall Aero Modellers is a neighbour to the solar plant. The meeting met their information needs. A key issue is explaining the technology. Completely agrees with the Barlow Solar Energy Centre as currently proposed by Barlow Energy Center LP.	N/A	N/A	N/A
8	Public Meeting Questionnaire	April 24, 2017	Attended for an update on project progress. The meeting met their information needs. A key issue is the need to advertise more. Completely agrees with the Barlow Solar Energy Centre as currently proposed by Barlow Energy Center LP.	N/A	N/A	N/A
9	Public Meeting Questionnaire	April 24, 2017	Attended for work. The meeting met their information needs. A key issue is to keep the locals happy. Has no information about the local environment. Provides services that might be useful during construction or operation. Agrees with the Barlow Solar Energy Centre as currently proposed by Barlow Energy Center LP.	N/A	N/A	N/A

Record	Type	Date	Subject Matter	Project Response	Date of Response	Follow-up
10	Public Meeting Questionnaire	April 24, 2017	Attending to get updated. The meeting met his information needs. Key issues are that people grumble but don't go to meetings themselves to get information. Information about the environment is the dump across the road. Agrees with the Barlow Solar Energy Centre as currently proposed by Barlow Energy Center LP. Provided a general comment regarding power in Ontario.	N/A	N/A	N/A
11	Public Meeting Questionnaire	April 25, 2017	The meeting met his information needs. Key issues are to guarantee longevity and repurpose panels. Has no information about the local environment. Provides services that might be useful during construction or operation. Agrees with the Barlow Solar Energy Centre as currently proposed by Barlow Energy Center LP.  Question: Where do panels go once broken, or replaced?	Response provided verbally at the public meeting.  Lease agreement clearly states that project owner needs to remove all equipment from site and restore the land it was in prior to condition prior to construction.  Renewable Energy Approval includes a commitment that project components will be removed from site at the end of the project and land restored to condition it was in prior to construction.  Solar panels are either recycled or disposed of in a manner that conforms to all government, environmental and legal requirements.  The standard practice of EDF EN Canada is to	April 25, 2017	N/A

Record	Type	Date	Subject Matter	Project Response	Date of Response	Follow-up
				negotiate a recycling/disposal provision within their solar panel supply agreements that typically includes recycling and/or disposal and logistics (i.e., who picks up the panels, ships them where, at what cost).		
12	Public Meeting Questionnaire	April 25, 2017	Attending to obtain knowledge. The meeting met his information needs. Key issues are noise and vibration. Has no information about the local environment. Provides no services that might be useful during construction or operation. Completely agrees with the Barlow Solar Energy Centre as currently proposed by Barlow Energy Center LP.	N/A	N/A	N/A
13	Public Meeting Questionnaire	April 25, 2017	Attending to learn about the process, the benefits, the effects on the environment and the decommissioning process. The meeting met their information needs.	N/A	N/A	N/A
14	Public Meeting Questionnaire	April 25, 2017	Attending because provides construction services. The meeting met their information needs. Has no information about the local environment. Provides services that might be useful during construction or operation. Agrees with the Barlow Solar Energy Centre as currently proposed by Barlow Energy Center LP.	N/A	N/A	N/A
15	Email	May 18, 2017	Interested in site revegetation following construction.	Communicating with Raisin Region Conservation Authority to determine appropriate vegetation to integrate beneath solar	May 18, 2017	N/A



Record	Type	Date	Subject Matter	Project Response	Date of Response	Follow-up
				panels and within site.		
<b>AGENCY</b>						
<b>MNRF</b>						
1	Email	Nov 17, 2016	Ministry of Natural Resources and Forestry confirms that engineer's report to develop within 75 m of a pipeline such as Trans-Northern Pipeline bisecting the site is not required. It is required for pipelines that are part of a well gathering or production system.	N/A	N/A	N/A
<b>MOECC</b>						
1	Email	August 10, 2016	Provided list of Aboriginal communities with a potential interest in the Project.	Reviewed and updated contact list	N/A	N/A
2	Email	October 27, 2016	Confirmed methodology for the Acoustics Assessment.	Implemented for the Acoustics Assessment	N/A	N/A
3		January 3, 2017	Provided further clarification on methodology for the Acoustics Assessment.	Implemented for the Acoustics Assessment	N/A	N/A
<b>MTCS</b>						
1	Email	June 30, 2016	Confirmed no provincial heritage properties in/adjacent to the study area.	N/A	N/A	N/A
<b>Raisin Region Conservation Authority</b>						
1	Meeting	September 20, 2016	Confirmed Project location is in a floodplain. Discussed pre and post construction survey requirements, and decommissioning requirements. Noted that electrical components would need to be at least .3 m above the floodplain level. Discussed the diverted creek to the perimeter of the site, and watercourse	Committed to on-going consultation.	N/A	See #2

Record	Type	Date	Subject Matter	Project Response	Date of Response	Follow-up
			setbacks. Discussed the implications of the floodplain.			
2	Meeting	March 9, 2017	Discussed permitting requirements, chemicals stored on-site, and landscaping.	Committed to providing a formal response.	N/A	Any permits will be applied for outside of the REA process.  EDF-EN committed to providing a list of chemicals.  CA to be involved in site landscaping efforts.
3	Meeting	April 20, 2017	Expressed interests regarding groundwater contamination, solar panels contaminating the site, road deterioration, project financing, decommissioning, and the agricultural nature of the site.	Committed to providing a formal response.	N/A	Undertook design measures to address design within the floodplain, such as elevating equipment.  Any permits will be applied for outside of the REA process.  Added reference to

Record	Type	Date	Subject Matter	Project Response	Date of Response	Follow-up
						presence of floodplain in REA reports.
4	Email	May 01, 2017	Message from the Project Team, seeking advice on how to respond to Board questions, how to acquire permits, and confirming that ground water contamination will be addressed as part of the renewable energy approval.	N/A	N/A	N/A
<b>MUNICIPAL</b>						
1	Letter	April 24, 2015	Resolution that the Council supports the development, construction, and operation of the project	N/A	N/A	N/A
2	Meeting	April 12, 2016	General discussion regarding the project and potential permits	Informed future consultation with the Township	N/A	N/A
3	Email	May 16, 2016	Confirmed no municipal heritage interest	Informed the Heritage Checklist	N/A	N/A
4	Email	May 25, 2016	No significant historical items related to the property	Informed the Heritage Checklist	N/A	N/A
5	Meeting	August 24, 2016	Reviewed the project status	Informed future consultation with the Township	N/A	N/A
6	Meeting	September 1, 2016	General discussion regarding the project	Informed future consultation with the City	N/A	N/A
7	Email	September 1, 2016	City of Cornwall confirms that no actual or proposed Draft Plans of Subdivision or Condominium in proximity to the Barlow Solar Energy Centre.	Noted	N/A	N/A

Record	Type	Date	Subject Matter	Project Response	Date of Response	Follow-up
8	Meeting	September 20, 2016	Discussed the municipal access agreement	Informed future consultation regarding the agreement	N/A	N/A
9	Email	November 18, 2016	Provided feedback on municipal drains, site entrance and the floodplain	Informed future consultation with the Township	N/A	N/A
10	Email	January 4, 2017	Provided information on a closed landfill south of the Study Area	Comment noted	N/A	N/A
11	Meeting	March 9, 2017	Discussed permits, emergency response, communication, internal roads, and landscaping	<p>Committed to obtaining all necessary municipal permits.</p> <p>A commitment of the Design and Operations Report is the development of an Emergency Response Plan, which will be prepared in consultation with emergency service providers. The Plan will be implemented by any owner of the project, and will include information on training requirements. A request for a tour of the facility is noted.</p> <p>Project will include a plan for communicating any ownership changes within project asset management documentation.</p> <p>A commitment was made to consider minimizing the amount of internal roads. Comments were noted regarding landscaping.</p>	N/A	N/A

Record	Type	Date	Subject Matter	Project Response	Date of Response	Follow-up
12	Letter	April 26, 2017	<p>Township of South Stormont Council passed a resolution indicating:</p> <p>a) continued support for the project</p> <p>b) that the project voluntarily submit to the Raisin Region Conservation Authority permitting process during implementation stage of the proposal to permit the roads and structures within the floodplain</p> <p>c) provide screening along Cornwall Centre Road (i.e. trees)</p> <p>d) shipping containers be screened in accordance with Zoning By-Law 2011-100</p> <p>e) work closely with the South Stormont Fire Protection Services on the design of access roads, training requirements, the development of a response plan,</p> <p>f) a transition plan for any future ownership changes.</p>	<p>Project design taking into consideration feedback from Raisin Region Conservation Authority, such as elevating equipment above floodplain.</p> <p>Entering a voluntary process to acquire permit to develop within floodplain with Raisin Region Conservation Authority.</p> <p>Shipping containers will be screened by fencing or other means.</p> <p>Trees along project boundary will eventually provide additional screening.</p> <p>A commitment of the Design and Operations Report is the development of an Emergency Response Plan, which will be prepared in consultation with emergency service providers. The Plan will be implemented by any owner of the project, and will include information on training requirements. Request for input into access road design is noted.</p> <p>Sharing emergency numbers and procedures</p>	N/A	Committed to on-going consultation

Record	Type	Date	Subject Matter	Project Response	Date of Response	Follow-up
				with local emergency response. Project will include a plan for communicating any ownership changes within project asset management documentation.		
13	Email	May 28, 2017	Outreach by the Project Team to confirm they are in communication with the Raisin River Conservation Authority regarding vegetation.	N/A	N/A	N/A
<b>ABORIGINAL</b>						
<b>MOHAWKS OF AWKESASNE</b>						
1	Email	March 28, 2016	Outreach by the Project Team to introduce the project, note upcoming archaeology fieldwork, and offer a meeting.	N/A	N/A	See #2
2	Telephone	April 28, 2016	Discussion regarding appropriate project contacts moving forward.	N/A	N/A	See #3
3	Telephone	April 29, 2016	Project Team asked if there was interest in participating in the Stage 2 archaeology fieldwork.	N/A	N/A	See #4
4	Email	May 5, 2016	Project Team provided a slide deck presentation about the Project, a copy of the Site Considerations Report, and an invitation to meet.	N/A	N/A	See #5
5	Email	May 9, 2016	Project Team once again offered a meeting.	N/A	N/A	See #6
6	Telephone	May 16, 2016	Project Team left voice messages indicating that natural heritage studies would take place in June, and asking if anyone from the community would have	N/A	N/A	See #7

Record	Type	Date	Subject Matter	Project Response	Date of Response	Follow-up
			an interest to participate. An offer to meet in person was again extended. A voice message also followed up on previous materials shared about the Project and offered an in-person follow-up meeting.			
7	Meeting	May 27, 2016	Suggestions occurred regarding vegetation planting at the site, and requests were made for MET data, to be included in natural heritage field studies, to be informed if medicinal plants are found during the natural heritage field studies, and to be included in procurement opportunities during construction.	Committed to working with the Mohawks of Akwesasne to identify procurement opportunities during construction. Noted that MET data cannot be shared. Representatives participated in the natural heritage site visit, and no medicinal plants were identified. The Project Team is communicating with the Raisin Region Conservation authority regarding the appropriate species to vegetate the ground beneath the solar panels.	May 27, 2016	See #8
8	Email	July 6, 2016	Confirmed that an in-person meeting was not necessary, but that his office would like to receive any archaeology reports and asked to acquire details about the Project.	N/A	N/A	See #9
9	Telephone	October 3, 2016	Project Team left a message to obtain feedback on the natural heritage site visit and determine opportunities for future engagement.	N/A	N/A	See #10
10	Telephone	February 14, 2017	Project Team left a message to obtain feedback on the natural heritage site visit and determine opportunities for future engagement.	N/A	N/A	Meeting Scheduled for May 27, 2017

Record	Type	Date	Subject Matter	Project Response	Date of Response	Follow-up
<b>NATION HURONNE WENDAT</b>						
1	Telephone	February 3, 2017	Voice message from the Project Team requesting appropriate contact moving forward.	Updated contact list.	N/A	See #2
2	Email	February 6, 2017	Outreach by the Project Team including information on the project status and offering to meet.	N/A	N/A	See #3
3	Emails	April 19, 2017	Voice message from the Project Team providing information on the Project.	N/A	N/A	See #4
4	Meeting	May 16, 2017	Discussed the project and FN interest in archaeology and construction support.	While archaeology is complete, a commitment was made to identify procurement opportunities during construction.	May 16, 2017	See #5
5	Telephone	May 18, 2017	Discussed that received the draft REA reports, and that their main interest is archaeology.	N/A	N/A	On--Going
<b>ALGONQUINS OF ONTARIO</b>						
1	Telephone	November 24, 2016	Noted that the Consultation Office is aware of the project and is considering their position.	N/A	N/A	See #2
2	Email	Feb 2, 2017	Project Team followed-up to inform that they will receive draft project reports in the coming weeks and ask if any follow up meetings, in person or on the phone are preferred.	N/A	N/A	On-Going
<b>ALGONQUINS OF PIKWAKANAGAN FIRST NATION</b>						
1	Email	March 21, 2016	Outreach by the Project Team to provide an update regarding the Project, note upcoming archaeology fieldwork, and	N/A	N/A	See #2



Record	Type	Date	Subject Matter	Project Response	Date of Response	Follow-up
			offer a meeting.			
2	Email	May 9, 2016	Requested a copy of archaeological reports	See #5	See #5	See #3
3	Telephone	September 20, 2016	Discussed the status of archaeology fieldwork, and opportunities for future engagement.	N/A	N/A	See #4
4	Telephone	February 9, 2017	Discussed opportunities for future engagement.	N/A	N/A	See #5
5	Meeting	May 10, 2017	Provided a Project update. A request was made for a copy of archaeology reports, to reach out to a certain individual regarding the consultation process, and to be involved in construction support.	Archaeology reports have been shared, and Barlow Solar Energy Centre Limited Partnership has committed to working with the First Nation regarding on-going consultation and to identify procurement opportunities during construction.	May 10, 2017	On-Going
<b>MÉTIS NATION OF ONTARIO</b>						
1	Telephone	April 28, 2016	Request made by Stantec for Regional Council contact information.	Updated contact list.	N/A	See #2
2	Email	May 2, 2016	The President of the Ottawa Region Métis Council got in touch to express interest in the Project and having a meeting.	Response by the Project Team suggesting meeting availability, and offering monitoring opportunities for archaeology.	May 2, 2016	See #4
3	Email	May 2, 2016	Outreach by the Project Team to the MNO Region 6 Captain of the Hunt Liaison Coordinator.	N/A	N/A	On-Going
4	Email	May 9, 2016	Follow-up by the Project Team to the President of the of the Ottawa Region Métis Council suggesting meeting availability,	N/A	N/A	On-Going

Record	Type	Date	Subject Matter	Project Response	Date of Response	Follow-up
			and offering monitoring opportunities for archaeology.			

# APPENDIX D PROJECT DISTRIBUTION LIST

**BARLOW SOLAR ENERGY CENTRE  
PROJECT DISTRIBUTION LIST**

First Name	Last Name	Title	Representing	Address	Town	Province	Postal Code	Phone	Email
<b>AGENCIES</b>									
Steve	Burns	District Manager	Ministry of Environment and Climate Change - Ottawa District Office	103-2430 Don Reid Dr.	Ottawa	Ontario	K1H 1E1	(613) 521 3450 ext. 224	steve.burns@ontario.ca
Kathleen	Hedley	Director - Environmental Approvals Branch	Ministry of Environment and Climate Change - Environmental Approvals Branch	1st Flr 135 St. Clair Ave W	Toronto	Ontario	M4V 1P5	(416) 314 7288	kathleen.hedley@ontario.ca
Mohsen	Keyvani	Supervisor, REA Unit	Ministry of Environment and Climate Change - Environmental Approvals Branch	1st Flr 135 St. Clair Ave W	Toronto	Ontario	M4V 1P5	(416) 326 6095	mohsen.keyvani@ontario.ca
Mansoor	Mahmood	Manager, Approvals Services	Ministry of Environment and Climate Change - Environmental Approvals Branch	1st Flr 135 St. Clair Ave W	Toronto	Ontario	M4V 1P5	(416) 314 3636	mansoor.mahmood@ontario.ca
Sarah	Paul	Director - Environmental Approvals Access and Service Integration Branch	Ministry of Environment and Climate Change	1st Flr 135 St. Clair Ave W	Toronto	Ontario	M4V 1P5	(416) 314-8171	sarah.paul@ontario.ca
Michael	Seguin	Supervisor	Ministry of Environment and Climate Change - Cornwall Area Office	1st Flr 113 Amelia St	Cornwall	Ontario	K6H 3P1	613-933-2375	michael.seguin@ontario.ca
Stephanie	Valade	Senior Environmental Officer	Ministry of Environment and Climate Change	1st Flr, 113 Amelia St	Cornwall	Ontario	K6H 3P1	613-933-7404	Stephanie.Valade@ontario.ca
Zeljko	Romic	Senior Program Support Coordinator	Ministry of Environment and Climate Change - Service Integration Branch	1st Flr 135 St. Clair Ave W	Toronto	Ontario	M4V 1P5	416-314-8204	zeljko.romic@ontario.ca
Roger	Houde	General Manager	Raisin Region Conservation Authority	18045 County Road 2 P.O. Box 429	Cornwall	Ontario	K6H 5T2	(613) 938-3611 Ext. 222	roger.houde@rrca.on.ca
Kimberly	MacDonald	Manager of Planning and Regulations	Raisin Region Conservation Authority	18045 County Road 2 P.O. Box 429	Cornwall	Ontario	K6H 5T2	(613) 938-3611 Ext. 242	kim.macdonald@rrca.on.ca
<b>MUNICIPALITIES</b>									
Benjamin	De Haan	Director of Transportation and Planning Services	United Counties of Stormont, Dundas & Glengarry	26 Pitt Street	Cornwall	Ontario	K6J 3P2	(613) 932-1515 ext 3	b_dehaan@sdgcounties.ca
Helen	Thomson	Director of Council Services/Clerk	United Counties of Stormont, Dundas & Glengarry	26 Pitt Street	Cornwall	Ontario	K6J 3P2	(613) 932-1515 ext 203	hthomson@sdgcounties.ca
John	St. Marseille	General Manager, Infrastructure & Municipal Works	City of Cornwall	1225 Ontario Street	Cornwall	Ontario	K6H 5T9		jstmarseille@cornwall.ca
Stephen	Wintle	Division Manager, Infrastructure Planning	City of Cornwall	360 Pitt Street Box 877	Cornwall	Ontario	K6J 3P9		swintle@cornwall.ca
Manon	Levesque	Deputy City Clerk	City of Cornwall	360 Pitt Street, Box 877	Cornwall	Ontario	K6H 5T9	(613) 932-6252 Ext 2337	mlevesque@cornwall.ca
Michael	Fawthrop		City of Cornwall		Cornwall	Ontario			mfawthrop@cornwall.ca
Betty	De Haan	CAO	Township of South Stormont	2 Mille Roches Road, PO Box 84	Long Sault	Ontario	K0C 1P0	(613) 534 8889 Ext 200	betty@southstormont.ca
Loriann	Harbers	Director of Corporate Services / Clerk	Township of South Stormont	P.O. Box 84 2 Mille Roches Road	Long Sault	Ontario	K0C 1P0	(613) 534 8889 Ext 201	loriann@southstormont.ca

**BARLOW SOLAR ENERGY CENTRE  
PROJECT DISTRIBUTION LIST**

First Name	Last Name	Title	Representing	Address	Town	Province	Postal Code	Phone	Email
Stephanie	Morin	Planning Technical	Township of South Stormont	2 Mille Roches Road, PO Box 84	Long Sault	Ontario	K0C 1P0		stephanie@southstormont.ca
Peter	Young	Director of Planning/Economic Development Officer	Township of South Stormont	2 Mille Roches Road, PO Box 84	Long Sault	Ontario	K0C 1P0		peter@southstormont.ca
Saadia	Jamil	Planning Technical	Township of South Stormont	2 Mille Roches Road, PO Box 84	Long Sault	Ontario	K0C 1P0	613-534-8889 X211	saadia@southstormont.ca
Tammy	Hart	Deputy Mayor	Township of South Stormont	2 Mille Roches Road, PO Box 84	Long Sault	Ontario	K0C 1P0		thart@southstormont.ca
<b>ABORIGINAL COMMUNITIES</b>									
Janet	Stavinga	Executive Director	Algonquins of Ontario Consultation Office	31 Riverside Drive, Suite 101	Pembroke	Ontario	K8A 8R6		
Lisa	Meness	Funding Research Coordinator	Algonquins of Pikwakanagan First Nation	1657A Mishomis Inamo	Pikwakanagan	Ontario	K0J 1X0	613-625-2800 x 237	research.coordinator@pikwakanagan.ca
James	Wagar	Manager, Natural Resources and Consultations	Metis Nation of Ontario	311-75 Sherborne Street	Toronto	Ontario	M5A 2P9		JamesW@metisnation.org
Benny	Michaud	President	MNO Ottawa Region Métis Council	500 Old St. Patrick St, Unit 3	Ottawa	Ontario	K1N 9G4		president.ormc@gmail.com
Heather	Phillips	Acting Executive Director	Moahawk Council of Akwesasne	Office of the Council Chiefs, 101 Tewesapteni Road	Akwesasne	Ontario	K6H 0G5	613-575-2250 x 2120	
Peggy	Thompson-Pyke	Environmental Assessment Officer/Supervisor	Mohawk Council of Akwesasne	Office of the Council Chiefs, 101 Tewesapteni Road	Akwesasne	Ontario	K6H 0G5		peggy.pyke@akwesasne.ca
Philip	White-Cree	Researcher, Aboriginal Rights and Research Office	Mohawk Council of Akwesasne	Office of the Council Chiefs, 101 Tewesapteni Road	Akwesasne	Ontario	K6H 0G5	613.575.2348 ext 2204	phillip.whitecree@akwesasne.ca
Abraham	Benedict	Chief	Mohawks of Akwesasne	Office of the Council Chiefs, 101 Tewesapteni Road	Akwesasne	Ontario	K6H 0G5		
Konrad	Sioui	Grand Chief	Nation Huronne-Wendat	255, place Chef-Michel-Laveau	Wendake	Quebec	G0A 4V0		
Maxime	Picard	Project Coordinator - Ontario	Nation Huronne-Wendat	255, place Chef-Michel-Laveau	Wendake	Quebec	G0A 4V0		
<b>OTHER INTERESTED STAKEHOLDERS</b>									
Canadian National Railway Company				1 Administration Road	Concord	Ontario	L4K 1B9		
Canadian National Railway Company				935 de La Gauchetière Street West	Montreal	Quebec	H3B 2M9		

**BARLOW SOLAR ENERGY CENTRE  
PROJECT DISTRIBUTION LIST**

First Name	Last Name	Title	Representing	Address	Town	Province	Postal Code	Phone	Email
Lana	Kegel	Senior Real Estate Coordinator	Hydro One Networks Inc.	185 Clegg Road	Markham	Ontario	L6G 1B7	(905) 946-6277	Lana.Kegel@HydroOne.com
Derek	Thomas	Plant Manager - Cornwall & Kemptville - Ready-Mix Concrete & Aggregate	Lafarge Canada Inc.	255 Tenth Street East	Cornwall	K6H 2X4		613.933.4584	derek.thomas@lafargeholcim.com
AIS Data Collection Unit and Land Use Office			NAV CANADA	1601 Tom Roberts Road P.O. Box 9824, Station T	Ottawa	Ontario	K1G 6R2	(866) 577-0247	landuse@navcanada.ca
Ontario Power Generation Inc.				700 University Avenue	Toronto	Ontario	M5G 1X6		
M.	Speagle	Secretary Treasurer	Trans-Northern Pipeline Inc.	45 Vogell Road, Suite 310	Richmond Hill	Ontario	L4B 3P6	289-475-5366	mspeagle@tnpi.ca
Walter	Watt	Property Administrator	Trans-Northern Pipeline Inc.	45 Vogell Road, Suite 310	Richmond Hill	Ontario	L4B 3P6	289-475-5366	wwatt@tnpi.ca
Glenn	McKay	Interim Manager Field Services East	Trans-Northern Pipeline Inc.					(613) 360-1848	gmckay@tnpi.ca
M.	Speagle	Secretary Treasurer	Trans-Northern Pipeline Inc.	45 Vogell Road, Suite 310	Richmond Hill	Ontario	L4B 3P6	289-475-5366	mspeagle@tnpi.ca
Walter	Watt	Property Administrator	Trans-Northern Pipeline Inc.	45 Vogell Road, Suite 310	Richmond Hill	Ontario	L4B 3P6	289-475-5366	wwatt@tnpi.ca
Glenn	McKay	Interim Manager Field Services East	Trans-Northern Pipeline Inc.					(613) 360-1848	gmckay@tnpi.ca

# APPENDIX E ADDITIONAL MUNICIPAL CORRESPONDENCE



Stantec Consulting Ltd.  
300W-675 Cochrane Drive Markham ON L3R 0B8

August 25, 2016  
File: 160950878

**Attention:** «First\_Name» «Last\_Name», «Position»  
«Agency»  
«Address»  
«City», «Province» «Postal»

Dear «First\_Name» «Last\_Name»,

**Reference: Barlow Solar Energy Centre**

On March 9, 2016, the Barlow Energy Centre Limited Partnership was awarded a contract by the Independent Electricity System Operator for the proposed Barlow Solar Energy Centre (the Project). The Project is located in the Township of South Stormont (within the United Counties of Stormont, Dundas and Glengarry) and the City of Cornwall. Barlow Energy Centre Limited Partnership is now seeking Renewable Energy Approval (REA) for the Project by the Ministry of the Environment and Climate Change as per Ontario Regulation 359/09 (the Regulation) - under Part V.0.1 of the *Environmental Protection Act*. If approved, the Project will have a total maximum name plate capacity of 10 megawatts and will be a Class 3 Solar Facility according to the provisions of the Regulation.

On behalf of Barlow Energy Centre Limited Partnership, please find enclosed a copy of the combined Notice of Proposal to Engage in a Renewable Energy Project and Notice of Public Meeting and the Draft Project Description Report (Draft PDR) for the Project. A newsletter to provide a brief project update is also enclosed. In accordance with the Regulation, the first Public Meeting is scheduled for October 5<sup>th</sup> and 6<sup>th</sup>, 2016 to provide an overview of the Project components, activities and potential environmental impacts, and to allow for the exchange of information with the public. The Draft PDR will be made available at the Public Meeting, and can also be viewed on the project website at [www.edf-en.ca/projects/project\\_display/barlow-solar-energy-centre1](http://www.edf-en.ca/projects/project_display/barlow-solar-energy-centre1). Barlow Energy Centre Limited Partnership is also requesting that the municipality kindly make a copy of the Draft PDR and Notice of Public Meeting available at the Clerk's office for public consumption.

As required by the Regulation, a Municipal Consultation Form for the Project is attached. The consultation form is provided for the purpose of consulting on matters relating to municipal or local infrastructure and servicing, and will form the basis of our discussions surrounding the Project. As we progress through the REA process, additional project details (e.g., layout, technical reports, permit requirements) will be developed, provided, and confirmed in consultation with local lower- and upper-tier municipalities.

We look forward to working with you, and obtaining your valuable input as this project progresses through the regulatory approvals process. We hope that you will attend the Public Meeting

Design with community in mind





August 25, 2016

«First\_Name» «Last\_Name», «Position»

**Reference: Barlow Solar Energy Centre**

described in the attached notice. To submit written comments on the Draft PDR or to seek further information on the Project, please contact the undersigned and / or refer to the contact information below.

Kevin Campbell, Senior Developer  
Barlow Energy Centre Limited Partnership  
53 Jarvis Street, Ste. 300, Toronto, ON M5C 2H2  
Phone: (416) 216-5053  
Email: Kevin.Campbell@edf-en.ca

Regards,

**STANTEC CONSULTING LTD.**

Tanya Turk, M.Sc., P.Ag.  
Project Manager  
Phone: (905) 415-6416  
Tanya.Turk@stantec.com

Attachments: Notice of Proposal to Engage in a Renewable Energy Project and Notice of Public Meeting  
Draft Project Description Report  
Newsletter  
Municipal Consultation Form

cc. Kevin Campbell, Barlow Energy Centre Limited Partnership  
Fabiola Oribe, Barlow Energy Centre Limited Partnership

**From:** [Turk, Tanya](#)  
**To:** [jstmarseille@cornwall.ca](mailto:jstmarseille@cornwall.ca); [swintle@cornwall.ca](mailto:swintle@cornwall.ca); [mlevesque@cornwall.ca](mailto:mlevesque@cornwall.ca)  
**Subject:** Barlow Solar Energy Centre  
**Date:** Wednesday, August 31, 2016 11:15:16 AM  
**Attachments:** [160950879\\_NOC\\_Notice\\_201608.pdf](#)  
[MCF\\_Barlow.pdf](#)  
[20160824\\_News\\_BAR\\_1\\_Final\(2\).pdf](#)

---

Hello!

On March 9, 2016, the Barlow Energy Centre Limited Partnership was awarded a contract by the Independent Electricity System Operator for the proposed Barlow Solar Energy Centre (the Project). The Project is located in the Township of South Stormont (within the United Counties of Stormont, Dundas and Glengarry) and the City of Cornwall. Barlow Energy Centre Limited Partnership is now seeking Renewable Energy Approval (REA) for the Project by the Ministry of the Environment and Climate Change as per Ontario Regulation 359/09 (the Regulation) - under Part V.0.1 of the *Environmental Protection Act*. If approved, the Project will have a total maximum name plate capacity of 10 megawatts and will be a Class 3 Solar Facility according to the provisions of the Regulation.

On behalf of Barlow Energy Centre Limited Partnership, please find attached a copy of the combined Notice of Proposal to Engage in a Renewable Energy Project and Notice of Public Meeting. A newsletter to provide a brief project update is also enclosed. In accordance with the Regulation, the first Public Meeting is scheduled for October 5<sup>th</sup> and 6<sup>th</sup>, 2016 to provide an overview of the Project components, activities and potential environmental impacts, and to allow for the exchange of information with the public. A hard copy of the attached, including our Draft Project Description Report (Draft PDR) was couriered to the Deputy City Clerk (Manon Levesque) last week. The Draft PDR will be made available at the Public Meeting, and can also be viewed on the project website at [www.edf-en.ca/projects/project\\_display/barlow-solar-energy-centre1](http://www.edf-en.ca/projects/project_display/barlow-solar-energy-centre1).

As required by the Regulation, a Municipal Consultation Form for the Project is attached. The consultation form is provided for the purpose of consulting on matters relating to municipal or local infrastructure and servicing, and will form the basis of our discussions surrounding the Project. As we progress through the REA process, additional project details (e.g., layout, technical reports, permit requirements) will be developed, provided, and confirmed in consultation with local lower- and upper-tier municipalities.

We look forward to working with you, and obtaining your valuable input as this project progresses through the regulatory approvals process. We hope that you will attend the Public Meeting described in the attached notice. To submit written comments on the Draft PDR or to seek further information on the Project, please contact the undersigned and / or refer to the contact information below.

Kevin Campbell, Senior Developer  
Barlow Energy Centre Limited Partnership  
53 Jarvis Street, Ste. 300, Toronto, ON M5C 2H2  
Phone: (416) 216-5053  
Email: [Kevin.Campbell@edf-en.ca](mailto:Kevin.Campbell@edf-en.ca)

Regards,

**Tanya Turk, M.Sc., P.Ag.**

Project Manager  
Stantec  
300W-675 Cochrane Drive Markham ON L3R 0B8

Phone: 905-415-6416  
Cell: 416-428-9214  
[tanya.turk@stantec.com](mailto:tanya.turk@stantec.com)

The content of this email is the confidential property of Stantec and should not be copied, modified, retransmitted, or used for any purpose except with Stantec's written authorization. If you are not the intended recipient, please delete all copies and notify us immediately.

 Please consider the environment before printing this email.

Le contenu de ce courriel est la propriété confidentielle de Stantec et ne devrait pas être reproduit, modifié, distribué ou utilisé sans l'autorisation écrite de Stantec. Si vous avez reçu ce message par erreur veuillez supprimer sans délai toutes ses copies et nous en aviser immédiatement.

 Avant d'imprimer ce courriel, réfléchissez à l'impact sur l'environnement.

**PART A – To be completed by the Applicant before submitting to Municipality or Local Authority**
**Section 1 – Project Description**
**1.1 – Renewable Energy Project**

Project Name (Project identifier to be used as a reference in correspondence)

**Barlow Solar Energy Centre**

Project Location

 Same as Applicant Physical Address ?  Yes  No (if no, please provide site address information below)

**Civic Address – Street information (includes street number, name, type and direction)**

Unit Number	Street Number	Street Name
City/Town	Province	Postal Code
Telephone Number	Fax Number	Email Address (if available)

**Survey Address** (Not required if the Civic Address is provided)

Lot/Part	Concession/Reference Plan	Municipality/Unorganized Township
<b>part of 20 and 21</b>	<b>4</b>	<b>T. of South Stormont</b>
County/District	Province/State	Country
<b>UC Stormont, Dundas &amp; Gleng.</b>	<b>Ontario</b>	<b>Canada</b>
		Postal Code

Non Address Information (where the project spans many locations or a large rural area, specify how the project area relates to the address provided)

**See Appendix A of the draft Project Description Report**
**Geo Reference** (Southwest corner of property)

Map Datum	Zone	Accuracy Estimate
<b>NAD83</b>	<b>18</b>	<b>Teranet spec. est. within 10 m</b>
Geo Referencing Method	UTM Easting	UTM Northing
<b>none (data from FBS projected)</b>	<b>514596</b>	<b>4987701</b>

Project Phasing (outline construction, operation and decommissioning activities)

**A description of the key project activities are provided in the draft Project Description Report (Table 4-1). A project schedule is provided in Table 4-2.**
**1.2 – Environmental Context**

Describe negative environmental effects that may result from engaging in the project (consider construction, operation and decommissioning activities).

**Existing environmental features will be described as part of the REA application process through the completion of a Stage 1-2 Archaeological Assessment, Natural Heritage Assessment, Water Assessment, Design and Operation Report, and Construction Plan Report.**

Propose early avoidance/prevention/mitigation concepts and measures.

**Avoidance through proper siting of Project components is the most important preventative measure used for the Project including adherence to regulated setbacks. Please see the attached Draft Project Description Report for additional measures.**

### 1.3 – Renewable Energy Generation Facility

Type of Facility/Operation (select all that apply & complete all appropriate sections)

- |  |  |
|--|--|
| <input type="checkbox"/> Wind (Land Based)   | <input type="checkbox"/> Biofuel                       |
| <input type="checkbox"/> Wind (Off-Shore)    | <input checked="" type="checkbox"/> Solar Photovoltaic |
| <input type="checkbox"/> Biogas              | <input type="checkbox"/> Others(describe) _____        |
| <input type="checkbox"/> Thermal Treatment   | <input type="checkbox"/> Class (if applicable) _____   |
| <input type="checkbox"/> Anaerobic Digestion |  |

Name Plate Capacity 10 MWac	Expected Generation 10 MW	Service Area Township of South Stormont	Total Area of Site (hectares) 38
--------------------------------	------------------------------	--	-------------------------------------

Provide a description of the facilities equipment or technology that will be used to convert the renewable energy source or any other energy source to electricity

The Project Location will include the installation of solar panels (final number to be determined) pole mounted on solar arrays (final number to be determined). Further details are outlined in Section 4 of the Project Description Report.

### 1.4 – Renewable Energy Generation Activities

Describe the activities that will be engaged in as part of the renewable energy project

Key Project Activities are outlined in Section 4.5 of the draft Project Description Report.

## Section 2 – Supporting Documents

### 2.1 – Required Documents Distributed for Consultation

Requirement	Name of Draft Document	Date (yyyy/mm/dd)
DRAFT Project Description Report	Barlow Solar Energy Centre Draft Project Description Report	2016/08/25
DRAFT Design and Operations Report		
DRAFT Construction Plan Report		
DRAFT Decommissioning Plan Report		

### If applicable, as outlined in O. Reg. 359/09

DRAFT Archaeological Assessment		
DRAFT Heritage Assessment		
DRAFT Natural Heritage Assessment		
DRAFT Water Assessment		
DRAFT Effluent Management Plan Report		
DRAFT Emission Summary and Dispersion Modeling Report		
Dispersion Modeling Report		
DRAFT Hydrogeological Assessment Report		

Requirement	Name of Draft Document	Date (yyyy/mm/dd)
DRAFT Noise Study Report		
DRAFT Odour Study Report		
DRAFT Surface Water Assessment Report		
DRAFT Specifications Report		
DRAFT Off-shore Wind Report		

## 2.2 – Cross Reference to Part B Section 5 – Municipal Consultation Requirements

Requirement	Name(s) of Draft Document(s) and Page Numbers where Relevant Information can be Found
Infrastructure and Servicing	
Road Access	
Traffic Management Plans	
Municipal Service Connections (other than roads)	
Landscaping Design	
Emergency Management Procedures / Safety Protocols	
Easements or Restrictive Covenants	
Temporary Disturbance Areas / Municipal Infrastructure that could be Damaged During Construction	
Fire Hydrants and Connections to Existing Drainage, Water Works and Sanitary Sewers	
Buried Kiosks and Above-Grade Utility Vaults	
Building Code Permits and Licenses	
Natural Features and Water Bodies	
Archaeological Resource or Heritage Resource	

## 2.3 – Location where written draft reports can be obtained for public inspection

Identify the location where written draft reports can be obtained for public inspection (physical location for viewing and the applicants project website if one is available)

Hard Copy: Township of South Stormont municipal office (2 Mille Roches Road, Long Sault)

Hard Copy: City of Cornwall municipal office (360 Pitt Street, Cornwall)

Project Website: [www.edf-en.ca/projects/project\\_display/barlow-solar-energy-centre1](http://www.edf-en.ca/projects/project_display/barlow-solar-energy-centre1)

## Section 3 – Applicant Address and Contact Information

### 3.1 – Applicant Information (Owner of project/facility)

Applicant Name (legal name of individual or organization as evidenced by legal documents)

Barlow Energy Centre LP

Business Identification Number

250757697

Business Name (the name under which the entity is operating or trading - also referred to as trade name)

EDF-EN Canada

Same as Applicant Name

**Civic Address**

Unit Number 53	Street Number Jarvis	Street Name (Include type and direction) Street (Ste. 300)	Province ON – Ontario	Postal Code M5C 2H2
City/Town Toronto				

**Survey Address** (Not required if the Civic Address is provided)

Lot/Part	Concession/Reference Plan	Municipality/Unorganized Township		
County/District	Province/State	Country	Postal Code	

Non Address Information (where the project spans many locations or a large rural area, specify how the project area relates to the address provided)

**PART B – To be completed by the Municipality or local authority****Section 4 – Municipality or Local Authority Contact Information****4.1 – Municipal or local authority information (complete one of the following sections)**Local Municipality / Unorganized Township  Yes  No

Name of Municipality

**Address**

Unit Number	Street Number	Street Name (Include type and direction)	PO Box
City/Town			Postal Code
Telephone Number (incl. area code) ext.		Fax Number (incl. area code)	Mobile Number (incl. area code)

**Clerk**

Last Name	First Name	Middle Initial
Telephone Number (incl. area code)	Email Address	
Signature	Date (yyyy/mm/dd)	

Upper Tier Municipality  Yes  No

Name of Municipality

**Address**

Unit Number	Street Number	Street Name (Include type and direction)	PO Box
City/Town			Postal Code
Telephone Number (incl. area code) ext.		Fax Number (incl. area code)	Mobile Number (incl. area code)

**Clerk**

Last Name	First Name	Middle Initial
Telephone Number (incl. area code)	Email Address	
Signature	Date (yyyy/mm/dd)	

**Local Roads Area** Yes  No

Name of Local Roads Board

**Address**

Unit Number	Street Number	Street Name (Include type and direction)	PO Box
City/Town		Province	Postal Code
Telephone Number (incl. area code) ext.		Fax Number (incl. area code)	Mobile Number (incl. area code)

**Secretary-Treasurer**

Last Name	First Name	Middle Initial
Telephone Number (incl. area code)	Email Address	
Signature	Date (yyyy/mm/dd)	

**Local Service Board area** Yes  No

Name of Local Service Board

**Address**

Unit Number	Street Number	Street Name (Include type and direction)	PO Box
City/Town		Province	Postal Code
Telephone Number (incl. area code) ext.		Fax Number (incl. area code)	Mobile Number (incl. area code)

**Secretary**

Last Name	First Name	Middle Initial
Telephone Number (incl. area code)	Email Address	
Signature	Date (yyyy/mm/dd)	

**Section 5 – Consultation Requirements**

See Part A Section 2.2 to cross reference to locations in Draft Reports where information on specific Consultation Requirements can be found

**5.1 – Project Location**

Provide comment on the project location with respect to infrastructure and servicing.

**5.2 – Project Roads**

Provide comment on the proposed project's plans respecting proposed road access.

Identify any issues and provide recommendations with respect to road access.

Provide comment on any proposed Traffic Management Plans.



Identify any issues and provide recommendations with respect to the proposed Traffic Management Plans.

---

**5.3 – Municipal or Local Authority Service Connections**

Provide comment on the proposed project plans related to the location of and type of municipal service connections, other than roads.

---

Identify any issues and provide recommendations with respect to the type of municipal service connections, other than roads.

---

**5.4 – Facility Other**

Identify any issues and recommendations with respect to the proposed landscaping design for the facility.

---

Provide comment on the proposed project plans for emergency management procedures / safety protocols.

---

Identify any issues and recommendations with respect to the proposed emergency management procedures / safety protocols.

---

Identify any issues and recommendations with respect to any Easements or Restrictive Covenants associated with the Project Location.

---

## **5.5 – Project Construction**

Identify any issues and recommendations with respect to the:

- proposed rehabilitation of any temporary disturbance areas and any municipal or local authority infrastructure that could be damaged during construction
  - proposed location of fire hydrants and connections to existing drainage, water works and sanitary sewers
  - proposed location of buried kiosks and above-grade utility vaults
  - proposed location of existing and proposed gas and electricity lines and connections
  - Building Code permits and licenses
  - identification of any significant natural features and water bodies within the municipality or territory.
  - identification any archaeological resource or heritage resource
  - aerodromes and / or airports
-

The Barlow Newsletter is designed to provide you with the latest information about the Barlow Solar Energy Centre. This publication will help you learn about the project, its timelines, anticipated benefits and provide project contact information.

## ABOUT THE PROJECT

Selected by the Independent Electricity System Operator (IESO) under the Large Renewable Procurement I Request for Proposals ("LRP I RFP"), Barlow Solar Energy Centre is being realized by a partnership between EDF EN Canada and the Algonquins of Pikwàkanagàn First Nation.

The project will be situated on privately-owned land located within the Township of South Stormont and

utilize a right of way within the City of Cornwall to connect to the existing electricity distribution grid. Barlow Solar Energy Centre will have a capacity of 10 megawatts alternating current (MWac) and will generate enough power to meet the demand of about 2,000 homes.

Construction is planned for 2018, following the receipt of required provincial and municipal approvals and permits. Commercial operation is expected by the end of 2018.

## COMMUNITY BENEFITS

**The Township of South Stormont, county, as well as associated school boards and local residents will realize many benefits, including:**

- A Community Benefit Agreement to contribute funds on an annual basis to the Township of South Stormont for improving local infrastructure and services (nearly \$480,000 over the life of the project).
- Additional property tax revenues generated by the project that will help to supplement revenues for the Township of South Stormont, county and local school boards (nearly \$400,000 over the life of the project).
- Nearly one hundred (100) construction jobs at the peak of construction, providing opportunities for local employment and the hospitality sector.
- Important opportunities for the local and surrounding economy during construction through: the procurement of local services, contractors and materials for project construction (i.e. aggregate, landscaping, etc.).

## PROJECT TIMELINE

\*MOECC - Ministry of Environment and Climate Change  
Note: Public consultation continues throughout each phase of the project



# PROJECT STUDIES



SAMPLE OF ARCHAEOLOGICAL FIELD WORK

A number of studies are necessary as part of the approvals and permitting process. The following studies are either complete or underway:

- A natural heritage site investigation to identify if sensitive natural features such as wetlands or significant woodlands exist on or within 50m of the Project Location.
- An aquatic site investigation to identify if aquatic features, such as water bodies or streams, exist within 120 m of the Project Location.
- An archaeology assessment to determine the archaeological potential of the Project Location.
- A review of cultural heritage resources to identify heritage sites within or adjacent to the Project Location.

These studies identify sensitive features and identify mitigation measures to protect these features. No archaeological resources have been recovered during the Stage 2 Archaeology Assessment to date.

The noise assessment is an important study to be conducted later this year to confirm that sound propagating from project equipment during operation is less than 40 dB (equivalent to a quiet room) at the exterior of neighboring homes.

More details will be shared with the public and municipal and provincial agencies in the coming months as we complete our studies and associated reports.



TEST PIT SURVEY

## HOW SOLAR WORKS

- 1 - Energy from the sun falls onto the earth's surface each day in the form of sunlight.
- 2 - The sunlight is absorbed by the solar panel, converting sunlight into electricity.
- 3 and 4 - Electricity generated travels through distribution lines to homes and businesses.

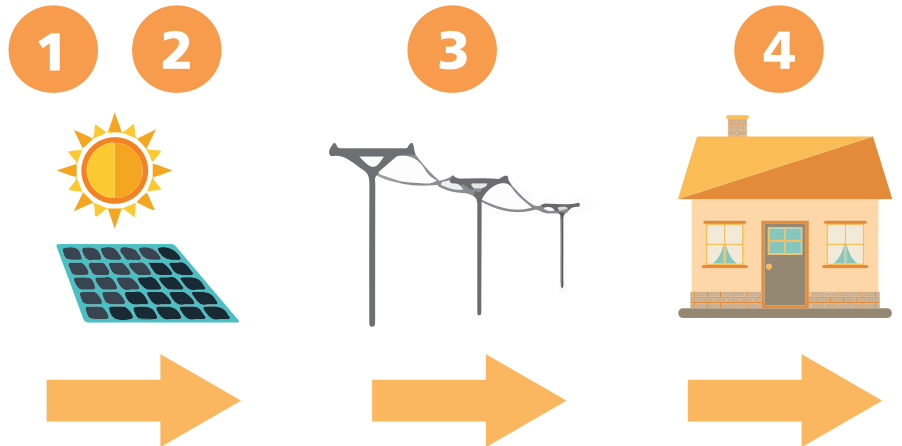

Crédits illustrations: 123rf -Yulia Drozdova; neonicflower

## STAY TUNED!

The second open house for the Barlow Solar Energy Centre is scheduled for Wednesday, October 5th (South Stormont Community Hall) and Thursday, October 6th (Best Western Plus Parkway Cornwall), from 5 PM to 8 PM. This is an opportunity for you to learn more about the solar energy centre and share with us your interests that should be considered during project planning. We encourage you to call or email us to be added to our mailing list, to share your thoughts about the project, or if you have any questions.

The project newsletter and open house details will also be on our website:  
[http://edf-en.ca/projects/project\\_display/barlow-solar-energy-centre1](http://edf-en.ca/projects/project_display/barlow-solar-energy-centre1)

### CONTACT US

Fabiola Oribe, Associate Developer and Stakeholder Relations.

Email: [BarlowSolar@edf-en.ca](mailto:BarlowSolar@edf-en.ca) / Phone: 1-844-55-EDF-EN



# NOTICE OF A PROPOSAL TO ENGAGE IN A RENEWABLE ENERGY PROJECT AND NOTICE OF PUBLIC MEETING

## To be held by Barlow Energy Centre Limited Partnership regarding a Proposal to Engage in a Renewable Energy Project

**Project Name:** Barlow Solar Energy Centre (the Project)

**Project Location:** The Project is located approximately 10 km west of the City centre of Cornwall, on two parcels of privately-owned land on the north side of Cornwall Centre Road, west of Power Dam Drive. The connection line would run approximately 1 km east along Cornwall Centre Road.

**Dated at** the Township of South Stormont within the United Counties of Stormont, Dundas and Glengarry, and the City of Cornwall, on this the first of September, 2016.

Barlow Energy Centre Limited Partnership is planning to engage in a renewable energy project in respect of which the issuance of a renewable energy approval is required. The distribution of this combined Notice of a Proposal to Engage in a Renewable Energy Project and Notice of Public Meeting, and the Project itself are subject to the provisions of the Environmental Protection Act (the Act) Part V.0.1 and Ontario Regulation 359/09 (the Regulation). This Notice must be distributed in accordance with section 15 of the Regulation prior to an application being submitted and assessed for completeness by the Ministry of the Environment and Climate Change.

**Project Description:**

Pursuant to the Act and Regulation, the facility, in respect of which the project is to be engaged in, is considered to be a Class 3 Solar Facility. If approved, this facility would have a total maximum name plate capacity of 10 MW. The project location is described in the map to the right.

**Documents for Public Inspection:**

The Project is being proposed in accordance with the requirements of the Act and Regulation. The Draft Project Description Report titled Pendleton Solar Energy Centre – Draft Project Description Report describes the facility as a solar energy generating facility that will be used to convert solar energy to electricity. A written copy of the Draft Project Description Report has been made available for public inspection during regular business hours at the Township of South Stormont municipal office (2 Mille Roches Road, Long Sault) as well as the City of Cornwall municipal office (360 Pitt Street, Cornwall) and online at [www.edf-en.ca/projects/project\\_display/barlow-solar-energy-centre1](http://www.edf-en.ca/projects/project_display/barlow-solar-energy-centre1). The Draft Project Description Report will also be made available at the public meeting, described below.

**Public Meeting Information:**

A Public Meeting is being held, and stakeholder input collected, as part of the above-noted regulatory process. The meeting will provide the community with the opportunity to meet the Project team, learn more about the proposed Project and the regulatory process, and provide comments and questions regarding the Project. We would appreciate your input and welcome your attendance at our drop-in style meeting.

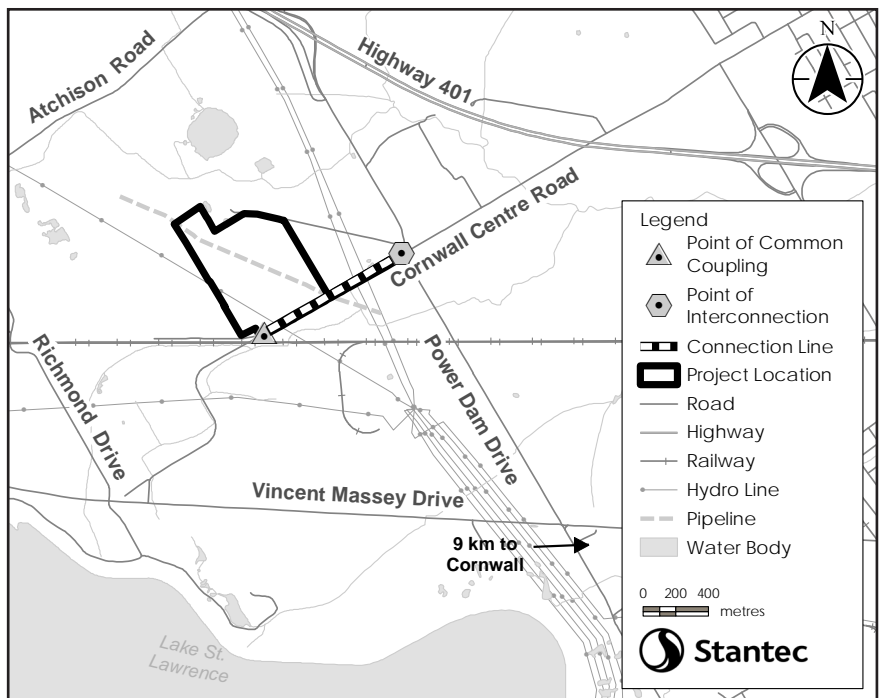

	Date	Wednesday October 5, 2016	Thursday October 6, 2016
<b>Public Meeting Locations</b>	<b>Time</b>	5:00 p.m. – 8:00 p.m.	5:00 p.m. – 8:00 p.m.
	<b>Place</b>	South Stormont Community Hall 2 Mille Roches Road, Long Sault	Best Western Parkway Inn & Conference Centre 1515 Vincent Massey Drive, Cornwall

**Project Contacts and Information:**

To learn more about the project proposal, public meeting, or to communicate concerns please refer to the contact information below.

Project Email Address: [BarlowSolar@edf-en.ca](mailto:BarlowSolar@edf-en.ca)  
 Toll-Free Phone Number: 1-844-55-EDF-EN  
 Project Website: [www.edf-en.ca/projects/project\\_display/barlow-solar-energy-centre1](http://www.edf-en.ca/projects/project_display/barlow-solar-energy-centre1)

**Fabiola Oribe**, Associate Project Developer and Stakeholder Relations  
 Pendleton Energy Centre Limited Partnership  
 53 Jarvis Street, Ste. 300, Toronto, ON M5C 2H2  
 Phone Number: 877.697.9997 (ext. 4146)

**From:** [Turk, Tanya](#)  
**To:** [betty@southstormont.ca](mailto:betty@southstormont.ca); [loriann@southstormont.ca](mailto:loriann@southstormont.ca); [stephanie@southstormont.ca](mailto:stephanie@southstormont.ca); [peter@southstormont.ca](mailto:peter@southstormont.ca)  
**Subject:** Barlow Solar Energy Centre  
**Date:** Wednesday, August 31, 2016 11:20:16 AM  
**Attachments:** [160950879\\_NOC\\_Notice\\_201608.pdf](#)  
[MCF\\_Barlow.pdf](#)  
[20160824\\_News\\_BAR\\_1\\_Final\\_\(2\).pdf](#)

---

Hello!

On March 9, 2016, the Barlow Energy Centre Limited Partnership was awarded a contract by the Independent Electricity System Operator for the proposed Barlow Solar Energy Centre (the Project). The Project is located in the Township of South Stormont (within the United Counties of Stormont, Dundas and Glengarry) and the City of Cornwall. Barlow Energy Centre Limited Partnership is now seeking Renewable Energy Approval (REA) for the Project by the Ministry of the Environment and Climate Change as per Ontario Regulation 359/09 (the Regulation) - under Part V.0.1 of the *Environmental Protection Act*. If approved, the Project will have a total maximum name plate capacity of 10 megawatts and will be a Class 3 Solar Facility according to the provisions of the Regulation.

On behalf of Barlow Energy Centre Limited Partnership, please find attached a copy of the combined Notice of Proposal to Engage in a Renewable Energy Project and Notice of Public Meeting. A newsletter to provide a brief project update is also enclosed. In accordance with the Regulation, the first Public Meeting is scheduled for October 5<sup>th</sup> and 6<sup>th</sup>, 2016 to provide an overview of the Project components, activities and potential environmental impacts, and to allow for the exchange of information with the public. A hard copy of the attached, including our Draft Project Description Report (Draft PDR) was couriered to the Director of Corporate Services / Clerk (Loriann Harbers) last week. The Draft PDR will be made available at the Public Meeting, and can also be viewed on the project website at [www.edf-en.ca/projects/project\\_display/barlow-solar-energy-centre1](http://www.edf-en.ca/projects/project_display/barlow-solar-energy-centre1).

As required by the Regulation, a Municipal Consultation Form for the Project is attached. The consultation form is provided for the purpose of consulting on matters relating to municipal or local infrastructure and servicing, and will form the basis of our discussions surrounding the Project. As we progress through the REA process, additional project details (e.g., layout, technical reports, permit requirements) will be developed, provided, and confirmed in consultation with local lower- and upper-tier municipalities.

We look forward to working with you, and obtaining your valuable input as this project progresses through the regulatory approvals process. We hope that you will attend the Public Meeting described in the attached notice. To submit written comments on the Draft PDR or to seek further information on the Project, please contact the undersigned and / or refer to the contact information below.

Kevin Campbell, Senior Developer  
Barlow Energy Centre Limited Partnership  
53 Jarvis Street, Ste. 300, Toronto, ON M5C 2H2  
Phone: (416) 216-5053  
Email: [Kevin.Campbell@edf-en.ca](mailto:Kevin.Campbell@edf-en.ca)

Regards,

**Tanya Turk, M.Sc., P.Ag.**

Project Manager  
Stantec  
300W-675 Cochrane Drive Markham ON L3R 0B8

Phone: 905-415-6416  
Cell: 416-428-9214  
[tanya.turk@stantec.com](mailto:tanya.turk@stantec.com)

The content of this email is the confidential property of Stantec and should not be copied, modified, retransmitted, or used for any purpose except with Stantec's written authorization. If you are not the intended recipient, please delete all copies and notify us immediately.

 Please consider the environment before printing this email.

Le contenu de ce courriel est la propriété confidentielle de Stantec et ne devrait pas être reproduit, modifié, distribué ou utilisé sans l'autorisation écrite de Stantec. Si vous avez reçu ce message par erreur veuillez supprimer sans délai toutes ses copies et nous en aviser immédiatement.

 Avant d'imprimer ce courriel, réfléchissez à l'impact sur l'environnement.

**PART A – To be completed by the Applicant before submitting to Municipality or Local Authority**
**Section 1 – Project Description**
**1.1 – Renewable Energy Project**

Project Name (Project identifier to be used as a reference in correspondence)

Barlow Solar Energy Centre

Project Location

 Same as Applicant Physical Address ?  Yes  No (if no, please provide site address information below)

**Civic Address – Street information (includes street number, name, type and direction)**

Unit Number	Street Number	Street Name
City/Town	Province	Postal Code
Telephone Number	Fax Number	Email Address (if available)

**Survey Address (Not required if the Civic Address is provided)**

Lot/Part part of 20 and 21	Concession/Reference Plan 4	Municipality/Unorganized Township T. of South Stormont
County/District UC Stormont, Dundas & Gleng.	Province/State Ontario	Country Canada
		Postal Code

Non Address Information (where the project spans many locations or a large rural area, specify how the project area relates to the address provided)

See Appendix A of the draft Project Description Report

**Geo Reference (Southwest corner of property)**

Map Datum NAD83	Zone 18	Accuracy Estimate Teranet spec. est. within 10 m
Geo Referencing Method none (data from FBS projected)	UTM Easting 514596	UTM Northing 4987701

Project Phasing (outline construction, operation and decommissioning activities)

A description of the key project activities are provided in the draft Project Description Report (Table 4-1). A project schedule is provided in Table 4-2.

**1.2 – Environmental Context**

Describe negative environmental effects that may result from engaging in the project (consider construction, operation and decommissioning activities).

Existing environmental features will be described as part of the REA application process through the completion of a Stage 1-2 Archaeological Assessment, Natural Heritage Assessment, Water Assessment, Design and Operation Report, and Construction Plan Report.

Propose early avoidance/prevention/mitigation concepts and measures.

Avoidance through proper siting of Project components is the most important preventative measure used for the Project including adherence to regulated setbacks. Please see the attached Draft Project Description Report for additional measures.



### 1.3 – Renewable Energy Generation Facility

Type of Facility/Operation (select all that apply & complete all appropriate sections)

- |  |  |
|--|--|
| <input type="checkbox"/> Wind (Land Based)   | <input type="checkbox"/> Biofuel                       |
| <input type="checkbox"/> Wind (Off-Shore)    | <input checked="" type="checkbox"/> Solar Photovoltaic |
| <input type="checkbox"/> Biogas              | <input type="checkbox"/> Others(describe) _____        |
| <input type="checkbox"/> Thermal Treatment   | <input type="checkbox"/> Class (if applicable) _____   |
| <input type="checkbox"/> Anaerobic Digestion |  |

Name Plate Capacity 10 MWac	Expected Generation 10 MW	Service Area Township of South Stormont	Total Area of Site (hectares) 38
--------------------------------	------------------------------	--	-------------------------------------

Provide a description of the facilities equipment or technology that will be used to convert the renewable energy source or any other energy source to electricity

The Project Location will include the installation of solar panels (final number to be determined) pole mounted on solar arrays (final number to be determined). Further details are outlined in Section 4 of the Project Description Report.

### 1.4 – Renewable Energy Generation Activities

Describe the activities that will be engaged in as part of the renewable energy project

Key Project Activities are outlined in Section 4.5 of the draft Project Description Report.

## Section 2 – Supporting Documents

### 2.1 – Required Documents Distributed for Consultation

Requirement	Name of Draft Document	Date (yyyy/mm/dd)
DRAFT Project Description Report	Barlow Solar Energy Centre Draft Project Description Report	2016/08/25
DRAFT Design and Operations Report		
DRAFT Construction Plan Report		
DRAFT Decommissioning Plan Report		

### If applicable, as outlined in O. Reg. 359/09

DRAFT Archaeological Assessment		
DRAFT Heritage Assessment		
DRAFT Natural Heritage Assessment		
DRAFT Water Assessment		
DRAFT Effluent Management Plan Report		
DRAFT Emission Summary and Dispersion Modeling Report		
Dispersion Modeling Report		
DRAFT Hydrogeological Assessment Report		

Requirement	Name of Draft Document	Date (yyyy/mm/dd)
DRAFT Noise Study Report		
DRAFT Odour Study Report		
DRAFT Surface Water Assessment Report		
DRAFT Specifications Report		
DRAFT Off-shore Wind Report		

## 2.2 – Cross Reference to Part B Section 5 – Municipal Consultation Requirements

Requirement	Name(s) of Draft Document(s) and Page Numbers where Relevant Information can be Found
Infrastructure and Servicing	
Road Access	
Traffic Management Plans	
Municipal Service Connections (other than roads)	
Landscaping Design	
Emergency Management Procedures / Safety Protocols	
Easements or Restrictive Covenants	
Temporary Disturbance Areas / Municipal Infrastructure that could be Damaged During Construction	
Fire Hydrants and Connections to Existing Drainage, Water Works and Sanitary Sewers	
Buried Kiosks and Above-Grade Utility Vaults	
Building Code Permits and Licenses	
Natural Features and Water Bodies	
Archaeological Resource or Heritage Resource	

## 2.3 – Location where written draft reports can be obtained for public inspection

Identify the location where written draft reports can be obtained for public inspection (physical location for viewing and the applicants project website if one is available)

Hard Copy: Township of South Stormont municipal office (2 Mille Roches Road, Long Sault)

Hard Copy: City of Cornwall municipal office (360 Pitt Street, Cornwall)

Project Website: [www.edf-en.ca/projects/project\\_display/barlow-solar-energy-centre1](http://www.edf-en.ca/projects/project_display/barlow-solar-energy-centre1)

## Section 3 – Applicant Address and Contact Information

### 3.1 – Applicant Information (Owner of project/facility)

Applicant Name (legal name of individual or organization as evidenced by legal documents)

Barlow Energy Centre LP

Business Identification Number

250757697

Business Name (the name under which the entity is operating or trading - also referred to as trade name)

EDF-EN Canada

Same as Applicant Name

**Civic Address**

Unit Number 53	Street Number Jarvis	Street Name (Include type and direction) Street (Ste. 300)	Province ON – Ontario	Postal Code M5C 2H2
City/Town Toronto				

**Survey Address** (Not required if the Civic Address is provided)

Lot/Part	Concession/Reference Plan	Municipality/Unorganized Township		
County/District	Province/State	Country	Postal Code	

Non Address Information (where the project spans many locations or a large rural area, specify how the project area relates to the address provided)

**PART B – To be completed by the Municipality or local authority****Section 4 – Municipality or Local Authority Contact Information****4.1 – Municipal or local authority information (complete one of the following sections)**Local Municipality / Unorganized Township  Yes  No

Name of Municipality

**Address**

Unit Number	Street Number	Street Name (Include type and direction)	PO Box
City/Town			Postal Code
Telephone Number (incl. area code) ext.		Fax Number (incl. area code)	Mobile Number (incl. area code)

**Clerk**

Last Name	First Name	Middle Initial
Telephone Number (incl. area code)	Email Address	
Signature	Date (yyyy/mm/dd)	

Upper Tier Municipality  Yes  No

Name of Municipality

**Address**

Unit Number	Street Number	Street Name (Include type and direction)	PO Box
City/Town			Postal Code
Telephone Number (incl. area code) ext.		Fax Number (incl. area code)	Mobile Number (incl. area code)

**Clerk**

Last Name	First Name	Middle Initial
Telephone Number (incl. area code)	Email Address	
Signature	Date (yyyy/mm/dd)	

**Local Roads Area** Yes  No

Name of Local Roads Board

**Address**

Unit Number	Street Number	Street Name (Include type and direction)	PO Box
City/Town		Province	Postal Code
Telephone Number (incl. area code) ext.		Fax Number (incl. area code)	Mobile Number (incl. area code)

**Secretary-Treasurer**

Last Name	First Name	Middle Initial
Telephone Number (incl. area code)	Email Address	
Signature	Date (yyyy/mm/dd)	

**Local Service Board area** Yes  No

Name of Local Service Board

**Address**

Unit Number	Street Number	Street Name (Include type and direction)	PO Box
City/Town		Province	Postal Code
Telephone Number (incl. area code) ext.		Fax Number (incl. area code)	Mobile Number (incl. area code)

**Secretary**

Last Name	First Name	Middle Initial
Telephone Number (incl. area code)	Email Address	
Signature	Date (yyyy/mm/dd)	

**Section 5 – Consultation Requirements**

See Part A Section 2.2 to cross reference to locations in Draft Reports where information on specific Consultation Requirements can be found

**5.1 – Project Location**

Provide comment on the project location with respect to infrastructure and servicing.

**5.2 – Project Roads**

Provide comment on the proposed project's plans respecting proposed road access.

Identify any issues and provide recommendations with respect to road access.

Provide comment on any proposed Traffic Management Plans.

Identify any issues and provide recommendations with respect to the proposed Traffic Management Plans.

---

**5.3 – Municipal or Local Authority Service Connections**

Provide comment on the proposed project plans related to the location of and type of municipal service connections, other than roads.

---

Identify any issues and provide recommendations with respect to the type of municipal service connections, other than roads.

---

**5.4 – Facility Other**

Identify any issues and recommendations with respect to the proposed landscaping design for the facility.

---

Provide comment on the proposed project plans for emergency management procedures / safety protocols.

---

Identify any issues and recommendations with respect to the proposed emergency management procedures / safety protocols.

---

Identify any issues and recommendations with respect to any Easements or Restrictive Covenants associated with the Project Location.

---

## **5.5 – Project Construction**

Identify any issues and recommendations with respect to the:

- proposed rehabilitation of any temporary disturbance areas and any municipal or local authority infrastructure that could be damaged during construction
  - proposed location of fire hydrants and connections to existing drainage, water works and sanitary sewers
  - proposed location of buried kiosks and above-grade utility vaults
  - proposed location of existing and proposed gas and electricity lines and connections
  - Building Code permits and licenses
  - identification of any significant natural features and water bodies within the municipality or territory.
  - identification any archaeological resource or heritage resource
  - aerodromes and / or airports
-

The Barlow Newsletter is designed to provide you with the latest information about the Barlow Solar Energy Centre. This publication will help you learn about the project, its timelines, anticipated benefits and provide project contact information.

## ABOUT THE PROJECT

Selected by the Independent Electricity System Operator (IESO) under the Large Renewable Procurement I Request for Proposals ("LRP I RFP"), Barlow Solar Energy Centre is being realized by a partnership between EDF EN Canada and the Algonquins of Pikwàkanagàn First Nation.

The project will be situated on privately-owned land located within the Township of South Stormont and

utilize a right of way within the City of Cornwall to connect to the existing electricity distribution grid. Barlow Solar Energy Centre will have a capacity of 10 megawatts alternating current (MWac) and will generate enough power to meet the demand of about 2,000 homes.

Construction is planned for 2018, following the receipt of required provincial and municipal approvals and permits. Commercial operation is expected by the end of 2018.

## COMMUNITY BENEFITS

**The Township of South Stormont, county, as well as associated school boards and local residents will realize many benefits, including:**

- A Community Benefit Agreement to contribute funds on an annual basis to the Township of South Stormont for improving local infrastructure and services (nearly \$480,000 over the life of the project).
- Additional property tax revenues generated by the project that will help to supplement revenues for the Township of South Stormont, county and local school boards (nearly \$400,000 over the life of the project).
- Nearly one hundred (100) construction jobs at the peak of construction, providing opportunities for local employment and the hospitality sector.
- Important opportunities for the local and surrounding economy during construction through: the procurement of local services, contractors and materials for project construction (i.e. aggregate, landscaping, etc.).

## PROJECT TIMELINE

\*MOECC - Ministry of Environment and Climate Change  
Note: Public consultation continues throughout each phase of the project

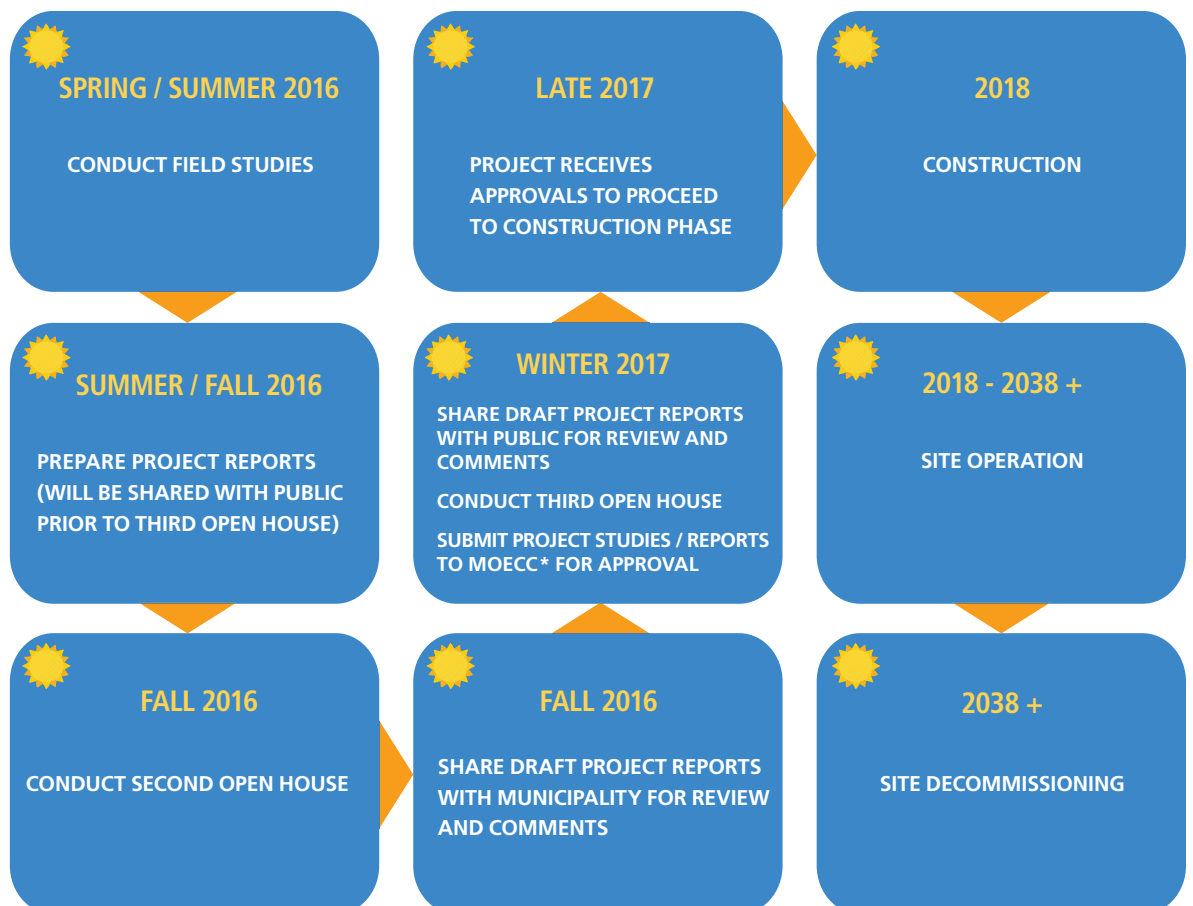

# PROJECT STUDIES



SAMPLE OF ARCHAEOLOGICAL FIELD WORK

A number of studies are necessary as part of the approvals and permitting process. The following studies are either complete or underway:

- A natural heritage site investigation to identify if sensitive natural features such as wetlands or significant woodlands exist on or within 50m of the Project Location.
- An aquatic site investigation to identify if aquatic features, such as water bodies or streams, exist within 120 m of the Project Location.
- An archaeology assessment to determine the archaeological potential of the Project Location.
- A review of cultural heritage resources to identify heritage sites within or adjacent to the Project Location.

These studies identify sensitive features and identify mitigation measures to protect these features. No archaeological resources have been recovered during the Stage 2 Archaeology Assessment to date.

The noise assessment is an important study to be conducted later this year to confirm that sound propagating from project equipment during operation is less than 40 dB (equivalent to a quiet room) at the exterior of neighboring homes.

More details will be shared with the public and municipal and provincial agencies in the coming months as we complete our studies and associated reports.



TEST PIT SURVEY

## HOW SOLAR WORKS

- 1 - Energy from the sun falls onto the earth's surface each day in the form of sunlight.
- 2 - The sunlight is absorbed by the solar panel, converting sunlight into electricity.
- 3 and 4 - Electricity generated travels through distribution lines to homes and businesses.

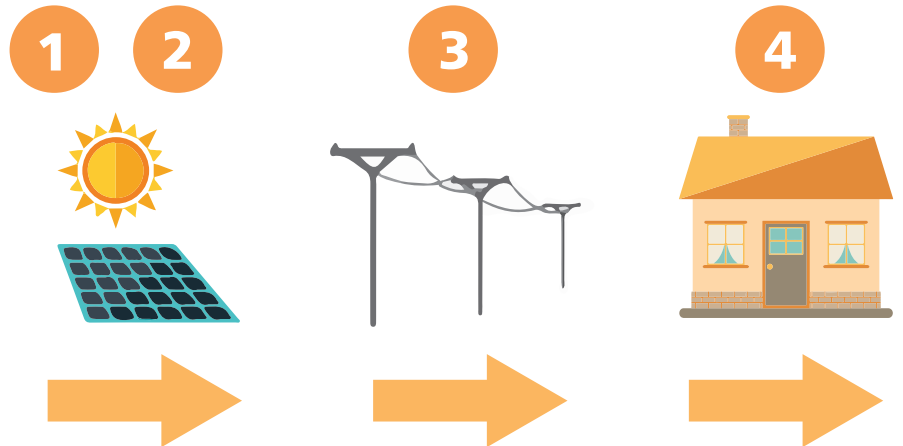

Crédits illustrations: 123rf -Yulia Drozdova; neonicflower

## STAY TUNED!

The second open house for the Barlow Solar Energy Centre is scheduled for Wednesday, October 5th (South Stormont Community Hall) and Thursday, October 6th (Best Western Plus Parkway Cornwall), from 5 PM to 8 PM. This is an opportunity for you to learn more about the solar energy centre and share with us your interests that should be considered during project planning. We encourage you to call or email us to be added to our mailing list, to share your thoughts about the project, or if you have any questions.

The project newsletter and open house details will also be on our website:  
[http://edf-en.ca/projects/project\\_display/barlow-solar-energy-centre1](http://edf-en.ca/projects/project_display/barlow-solar-energy-centre1)

### CONTACT US

Fabiola Oribe, Associate Developer and Stakeholder Relations.

Email: [BarlowSolar@edf-en.ca](mailto:BarlowSolar@edf-en.ca) / Phone: 1-844-55-EDF-EN





# NOTICE OF A PROPOSAL TO ENGAGE IN A RENEWABLE ENERGY PROJECT AND NOTICE OF PUBLIC MEETING

## To be held by Barlow Energy Centre Limited Partnership regarding a Proposal to Engage in a Renewable Energy Project

**Project Name:** Barlow Solar Energy Centre (the Project)

**Project Location:** The Project is located approximately 10 km west of the City centre of Cornwall, on two parcels of privately-owned land on the north side of Cornwall Centre Road, west of Power Dam Drive. The connection line would run approximately 1 km east along Cornwall Centre Road.

**Dated at** the Township of South Stormont within the United Counties of Stormont, Dundas and Glengarry, and the City of Cornwall, on this the first of September, 2016.

Barlow Energy Centre Limited Partnership is planning to engage in a renewable energy project in respect of which the issuance of a renewable energy approval is required. The distribution of this combined Notice of a Proposal to Engage in a Renewable Energy Project and Notice of Public Meeting, and the Project itself are subject to the provisions of the Environmental Protection Act (the Act) Part V.0.1 and Ontario Regulation 359/09 (the Regulation). This Notice must be distributed in accordance with section 15 of the Regulation prior to an application being submitted and assessed for completeness by the Ministry of the Environment and Climate Change.

**Project Description:**

Pursuant to the Act and Regulation, the facility, in respect of which the project is to be engaged in, is considered to be a Class 3 Solar Facility. If approved, this facility would have a total maximum name plate capacity of 10 MW. The project location is described in the map to the right.

**Documents for Public Inspection:**

The Project is being proposed in accordance with the requirements of the Act and Regulation. The Draft Project Description Report titled Pendleton Solar Energy Centre – Draft Project Description Report describes the facility as a solar energy generating facility that will be used to convert solar energy to electricity. A written copy of the Draft Project Description Report has been made available for public inspection during regular business hours at the Township of South Stormont municipal office (2 Mille Roches Road, Long Sault) as well as the City of Cornwall municipal office (360 Pitt Street, Cornwall) and online at [www.edf-en.ca/projects/project\\_display/barlow-solar-energy-centre1](http://www.edf-en.ca/projects/project_display/barlow-solar-energy-centre1). The Draft Project Description Report will also be made available at the public meeting, described below.

**Public Meeting Information:**

A Public Meeting is being held, and stakeholder input collected, as part of the above-noted regulatory process. The meeting will provide the community with the opportunity to meet the Project team, learn more about the proposed Project and the regulatory process, and provide comments and questions regarding the Project. We would appreciate your input and welcome your attendance at our drop-in style meeting.

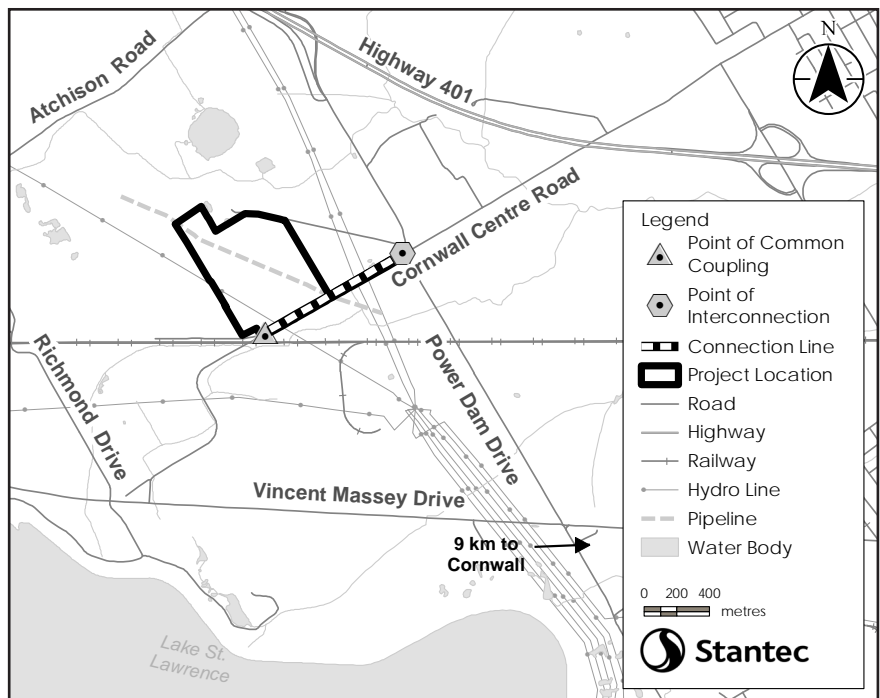

Public Meeting Locations	Date	Wednesday October 5, 2016	Thursday October 6, 2016
	Time	5:00 p.m. – 8:00 p.m.	5:00 p.m. – 8:00 p.m.
	Place	South Stormont Community Hall 2 Mille Roches Road, Long Sault	Best Western Parkway Inn & Conference Centre 1515 Vincent Massey Drive, Cornwall

**Project Contacts and Information:**

To learn more about the project proposal, public meeting, or to communicate concerns please refer to the contact information below.

Project Email Address: [BarlowSolar@edf-en.ca](mailto:BarlowSolar@edf-en.ca)  
 Toll-Free Phone Number: 1-844-55-EDF-EN  
 Project Website: [www.edf-en.ca/projects/project\\_display/barlow-solar-energy-centre1](http://www.edf-en.ca/projects/project_display/barlow-solar-energy-centre1)

**Fabiola Oribe**, Associate Project Developer and Stakeholder Relations  
 Pendleton Energy Centre Limited Partnership  
 53 Jarvis Street, Ste. 300, Toronto, ON M5C 2H2  
 Phone Number: 877.697.9997 (ext. 4146)

---

**From:** Turk, Tanya  
**Sent:** Friday, September 02, 2016 2:18 PM  
**To:** b\_dehaan@sdcgcounties.ca; hthomson@sdcgcounties.ca  
**Subject:** Barlow Solar Energy Centre  
**Attachments:** 160950879\_NOC\_Notice\_201608.pdf; MCF\_Barlow.pdf; 20160824\_News\_BAR\_1\_Final (2).pdf; let\_UnitedSDG\_info-request\_20160902.pdf; frm\_Barlow\_REA\_Site Plan Approval and Building Permit Request Form(2).pdf; 20160815\_160950878\_Barlow\_Receptors.xlsx

Hello!

On March 9, 2016, the Barlow Energy Centre Limited Partnership was awarded a contract by the Independent Electricity System Operator for the proposed Barlow Solar Energy Centre (the Project). The Project is located in the Township of South Stormont (within the United Counties of Stormont, Dundas and Glengarry) and the City of Cornwall. Barlow Energy Centre Limited Partnership is now seeking Renewable Energy Approval (REA) for the Project by the Ministry of the Environment and Climate Change as per Ontario Regulation 359/09 (the Regulation) - under Part V.0.1 of the *Environmental Protection Act*. If approved, the Project will have a total maximum name plate capacity of 10 megawatts and will be a Class 3 Solar Facility according to the provisions of the Regulation.

On behalf of Barlow Energy Centre Limited Partnership, please find attached a copy of the combined Notice of Proposal to Engage in a Renewable Energy Project and Notice of Public Meeting. A newsletter to provide a brief project update is also enclosed. In accordance with the Regulation, the first Public Meeting is scheduled for October 5<sup>th</sup> and 6<sup>th</sup>, 2016 to provide an overview of the Project components, activities and potential environmental impacts, and to allow for the exchange of information with the public. A hard copy of the attached Notice, Newsletter and Draft Project Description Report (Draft PDR) was couriered to the Director of Council Services/Clerk (Helen Thomson) today. The Draft PDR will be made available at the Public Meeting, and can also be viewed on the project website at [www.edf-en.ca/projects/project\\_display/barlow-solar-energy-centre1](http://www.edf-en.ca/projects/project_display/barlow-solar-energy-centre1).

As required by the Regulation, a Municipal Consultation Form for the Project is attached. The consultation form is provided for the purpose of consulting on matters relating to municipal or local infrastructure and servicing, and will form the basis of our discussions surrounding the Project. As we progress through the REA process, additional project details (e.g., layout, technical reports, permit requirements) will be developed, provided, and confirmed in consultation with local lower- and upper-tier municipalities.

As per O. Reg. 359/09, Section 1 (4.1), we are also writing to formally request a copy of each approval issued under section 41 of the Planning Act by the United Counties of Stormont, Dundas & Glengarry, in respect of a building or structure. Please see attached letter, map, receptor list, and Site Plan Approval and Building Permit Request Form, as required under O. Reg. 359/09.

We look forward to working with you, and obtaining your valuable input as this project progresses through the regulatory approvals process. We hope that you will attend the Public Meeting described in the attached notice. To submit written comments on the Draft PDR or to seek further information on the Project, please contact the undersigned and / or refer to the contact information below.

Kevin Campbell, Senior Developer  
Barlow Energy Centre Limited Partnership  
53 Jarvis Street, Ste. 300, Toronto, ON M5C 2H2  
Phone: (416) 216-5053  
Email: [Kevin.Campbell@edf-en.ca](mailto:Kevin.Campbell@edf-en.ca)

Thank you,

**Tanya Turk, M.Sc., P.Ag.**

Project Manager

Stantec

300W-675 Cochrane Drive Markham ON L3R 0B8

Phone: 905-415-6416

Cell: 416-428-9214

tanya.turk@stantec.com



The content of this email is the confidential property of Stantec and should not be copied, modified, retransmitted, or used for any purpose except with Stantec's written authorization. If you are not the intended recipient, please delete all copies and notify us immediately.

 Please consider the environment before printing this email.

Le contenu de ce courriel est la propriété confidentielle de Stantec et ne devrait pas être reproduit, modifié, distribué ou utilisé sans l'autorisation écrite de Stantec. Si vous avez reçu ce message par erreur veuillez supprimer sans délai toutes ses copies et nous en aviser immédiatement.

 Avant d'imprimer ce courriel, réfléchissez à l'impact sur l'environnement.

**From:** [Turk, Tanya](#)  
**To:** [mlevesque@cornwall.ca](mailto:mlevesque@cornwall.ca)  
**Cc:** [Kevin Campbell \(Kevin.Campbell@edf-en.ca\)](mailto:Kevin.Campbell@edf-en.ca)  
**Subject:** Site Plan Approval and Building Permit Request - Barlow Solar Energy Centre  
**Date:** Friday, August 26, 2016 3:44:15 PM  
**Attachments:** [let\\_CityofCornwall\\_info-request\\_20160826.pdf](#)  
[160950879\\_ProjectLocation\\_20160707.pdf](#)  
[frm\\_Barlow\\_REA\\_Site\\_Plan\\_Approval\\_and\\_Building\\_Permit\\_Request\\_Form\(2\).pdf](#)  
[20160815\\_160950878\\_Barlow\\_Receptors.xlsx](#)

---

Hello Manon Levesque

Barlow Energy Centre Limited Partnership is proposing to develop, construct, and operate a 10 megawatt alternating current solar energy generating facility, known as the Barlow Solar Energy Centre in the Township of South Stormont (within the United Counties of Stormont, Dundas and Glengarry) and the City of Cornwall. On behalf of Barlow Energy Centre Limited Partnership, and as per O. Reg. 359/09, Section 1 (4.1), we are writing to formally request a copy of each approval issued under section 41 of the Planning Act by the City of Cornwall, in respect of a building or structure. Please see attached letter, map, receptor list, and Site Plan Approval and Building Permit Request Form, as required under O. Reg. 359/09.

Please do not hesitate to contact me should you have any questions.

**Tanya Turk, M.Sc., P.Ag.**

Project Manager  
Stantec  
300W-675 Cochrane Drive Markham ON L3R 0B8  
Phone: 905-415-6416  
Cell: 416-428-9214  
[tanya.turk@stantec.com](mailto:tanya.turk@stantec.com)

The content of this email is the confidential property of Stantec and should not be copied, modified, retransmitted, or used for any purpose except with Stantec's written authorization. If you are not the intended recipient, please delete all copies and notify us immediately.

 Please consider the environment before printing this email.

Le contenu de ce courriel est la propriété confidentielle de Stantec et ne devrait pas être reproduit, modifié, distribué ou utilisé sans l'autorisation écrite de Stantec. Si vous avez reçu ce message par erreur veuillez supprimer sans délai toutes ses copies et nous en aviser immédiatement.

 Avant d'imprimer ce courriel, réfléchissez à l'impact sur l'environnement.

**Renewable Energy Approval  
Site Plan Approval and Building Permit  
Request Form  
Ontario Regulation 359/09  
Ce formulaire est disponible en français**

This form is intended to standardize the way in which applicants of wind facilities request copies of site plan approvals (issued under section 41 of the *Planning Act*) and building permits (issued under s. 8 of the *Building Code Act*, 1992) from municipalities when they are planning their projects.

Subject to exceptions, site plan approvals and building permits issued in respect of the following land uses are treated as noise receptors for the purposes of the Renewable Energy Approval regulation (O. Reg. 359/09):

1. A building or structure that contains one or more dwellings.
2. A building used for an institutional purpose, including an educational facility, a child care centre, a health care facility, a community centre or a place of worship.

**Municipalities are requested to provide copies of site plan approvals and building permits issued in respect of the above types of land uses. Property addresses have been provided by the applicant in section 2.**

**If a municipality does not provide a copy of each site plan approval or building permit issued in respect of the properties identified below within 60 days of receiving this request, then the proponent of the wind facility may not be required to consider those locations as noise receptors when planning their project and the 550 minimum setback and sound level limits would not apply.**

**Municipalities are requested to return this completed form with copies of requested site plan approvals and/or building permits (if applicable) to the applicant via mail, email, or in person. The applicant's contact information can be found in section 1.**

This form has been approved by the Director for the purpose of s. 1(4.2) of O. Reg. 359/09.

Cette publication hautement spécialisée "Site Plan d'approbation et de permis de construction Formulaire de demande" n'est disponible qu'en anglais conformément au Règlement 671/92, selon lequel il n'est pas obligatoire de la traduire en vertu de la *Loi sur les services en français*. Pour obtenir des renseignements en français, veuillez communiquer avec le ministère Ministère de l'Environnement et de l'Action en matière de changement climatique au 416-314-8001 ou 1-800-461-6290 ou par courriel à [MOE.ServiceIntegration@ontario.ca](mailto:MOE.ServiceIntegration@ontario.ca).

## Section 1 – Renewable Energy Project Description

NOTE: Applicant to complete this section

### Renewable Energy Project Information

Project Name (Project identifier to be used as a reference in correspondence)  
Barlow Solar Energy Centre

#### Project Location

##### Civic Address- Street information

Unit Number	Street Number	Street Name	PO Box
City/Town			Province
			ON - Ontario
			Postal Code

##### Survey Address (Not required if Street Information is provided)

Unit Number	Street Number	Street Name	PO Box
City/Town			Province
T. of South Stormont			ON - Ontario
			Postal Code
Lot	Conc	Part	Reference Plan
20 and 21	4		

Location Information (includes any additional information to clarify physical location e.g. municipality, ward/ township)  
please see attached map for project location.

#### Applicant Contact Information

Last Name	First Name	Middle Initial
Campbell	Kevin	

##### Address

Unit Number	Street Number	Street Name	PO Box
300	53	Jarvis Street	
City/Town			Province
Toronto			ON - Ontario
			Postal Code
			M5C 2H2
Telephone Number	Fax Number	Email Address	
416-216-5053 ext.		Kevin.Campbell@edf-en.ca	

#### Geo Reference (e.g. southwest corner of property)

Map Datum	Zone	Accuracy Estimate
NAD83	18	Teranet spec. estimate w/in 10 m
Geo Referencing Method	UTM Easting	UTM Northing
none (data from FBS projected)	514596	4987701

#### Non Address Information

(where the project spans many locations or a large rural area, specify how the project area relates to the address provided)  
The Project is located in the Township of South Stormont within the United Counties of Stormont, Dundas and Glengarry. It is situated on two parcels of privately-owned land, totaling approximately 94 ha, on the north side of Cornwall Centre Road, west of Power Dam Drive.

**Section 2 – Specific Information Requested**

**NOTE: Applicant and municipality or local authority to complete this section**

**Individual Property / Lot Search:** Applicant to identify addresses of surrounding properties for which they are seeking copies of site plans or building permits.

Applicant to complete information below (attach additional pages of information as required):		Municipality or local authority to complete information below:
Address / Lot #	Description of Property for which information is being sought (if necessary)	Has a site plan approval or building permit been issued in respect of the buildings or structures described above at this property?
See attached excel table.		<input type="checkbox"/> Yes (If yes, municipality to provide copy of approval or building permit) <input type="checkbox"/> No
		<input type="checkbox"/> Yes (If yes, municipality to provide copy of approval or building permit) <input type="checkbox"/> No
		<input type="checkbox"/> Yes (If yes, municipality to provide copy of approval or building permit) <input type="checkbox"/> No
		<input type="checkbox"/> Yes (If yes, municipality to provide copy of approval or building permit) <input type="checkbox"/> No
		<input type="checkbox"/> Yes (If yes, municipality to provide copy of approval or building permit) <input type="checkbox"/> No
		<input type="checkbox"/> Yes (If yes, municipality to provide copy of approval or building permit) <input type="checkbox"/> No
		<input type="checkbox"/> Yes (If yes, municipality to provide copy of approval or building permit) <input type="checkbox"/> No
		<input type="checkbox"/> Yes (If yes, municipality to provide copy of approval or building permit) <input type="checkbox"/> No
		<input type="checkbox"/> Yes (If yes, municipality to provide copy of approval or building permit) <input type="checkbox"/> No
		<input type="checkbox"/> Yes (If yes, municipality to provide copy of approval or building permit) <input type="checkbox"/> No
		<input type="checkbox"/> Yes (If yes, municipality to provide copy of approval or building permit) <input type="checkbox"/> No
		<input type="checkbox"/> Yes (If yes, municipality to provide copy of approval or building permit) <input type="checkbox"/> No
		<input type="checkbox"/> Yes (If yes, municipality to provide copy of approval or building permit) <input type="checkbox"/> No
		<input type="checkbox"/> Yes (If yes, municipality to provide copy of approval or building permit) <input type="checkbox"/> No

Address / Lot #	Description of Property for which information is being sought (if necessary)	Has a site plan approval or building permit been issued in respect of the buildings or structures described above at this property?
		<input type="checkbox"/> Yes (If yes, municipality to provide copy of approval or building permit) <input type="checkbox"/> No
		<input type="checkbox"/> Yes (If yes, municipality to provide copy of approval or building permit) <input type="checkbox"/> No
		<input type="checkbox"/> Yes (If yes, municipality to provide copy of approval or building permit) <input type="checkbox"/> No
		<input type="checkbox"/> Yes (If yes, municipality to provide copy of approval or building permit) <input type="checkbox"/> No
		<input type="checkbox"/> Yes (If yes, municipality to provide copy of approval or building permit) <input type="checkbox"/> No
		<input type="checkbox"/> Yes (If yes, municipality to provide copy of approval or building permit) <input type="checkbox"/> No



---

**Section 3 – Municipality or Local Authority Contact Information**

---

**NOTE: Municipality or local authority to complete this section****Municipal or local authority Information (complete one of the following sections)**Local Municipality  Yes  No

Name of Municipality

---

**Municipal Contact Name**

Last Name

First Name

---

**Address**

Unit Number

Street Number

Street Name

PO Box

City/Town

Province

Postal Code

Telephone Number

ext.

Fax Number

Email Address

Upper Tier Municipality  Yes  No

Name of Municipality

---

**Municipal Contact Name**

Last Name

First Name

---

**Address**

Unit Number

Street Number

Street Name

PO Box

City/Town

Province

Postal Code

Telephone Number

ext.

Fax Number

Email Address

Receptor	Verification	PIN	Lot	Concession	Geographic Township Name
Vacant Point of Reception	Y	602190061	LOT 24	CON 3	CORNWALL
Vacant Point of Reception	Y	602190062	LOT 23	CON 3	CORNWALL
Vacant Point of Reception	Y	602200099	LOT 23	CON 4	CORNWALL
Commercial	Y	602190063	LOT 22	CON 3	CORNWALL
Vacant Point of Reception	Y	602200150	LOT 23	CON 4	CORNWALL
Commercial	N	602190063	LOT 22	CON 3	CORNWALL
Commercial	N	602190078	LOT 20	CON 3	CORNWALL
Commercial	Y	602190065	LOT 22	CON 3	CORNWALL
Commercial	Y	602190078	LOT 20	CON 3	CORNWALL
Vacant Point of Reception	Y	602190077	LOT 21	CON 3	CORNWALL
Vacant Point of Reception	Y	602190067	LOT 22	CON 3	CORNWALL
Commercial	N	602100004	LOT 18	CON 3	CORNWALL
Commercial	Y	602190068	LOT 22	CON 3	CORNWALL
Point of Reception	Y	602200100	LOT 22	CON 4	CORNWALL
Commercial	N	602100005	LOT 18	CON 3	CORNWALL
Vacant Point of Reception	Y	602190069	LOT 20	CON 3	CORNWALL
Vacant Point of Reception	Y	602200064	LOT 24	CON 4	CORNWALL
Commercial	N	602200101	LOT 22	CON 4	CORNWALL
Commercial	Y	602200112	LOT 21	CON 4	CORNWALL
Vacant Point of Reception	Y	602190071	LOT 21	CON 3	CORNWALL
Vacant Point of Reception	Y	602200154	LOT 21	CON 4	CORNWALL
Vacant Point of Reception	Y	602190072	LOT 20	CON 3	CORNWALL
Vacant Point of Reception	Y	602200111	LOT 20	CON 4	CORNWALL
Vacant Point of Reception	Y	602190074	LOT 19	CON 3	CORNWALL
Point of Reception	Y	602190075	LOT 19	CON 3	CORNWALL
Commercial	Y	602190075	LOT 19	CON 3	CORNWALL
Vacant Point of Reception	Y	602200115	LOT 19	CON 4	CORNWALL
Vacant Point of Reception	Y	602200146	LOT 19	CON 4	CORNWALL
Point of Reception	Y	602190076	LOT 19	CON 3	CORNWALL
Point of Reception	Y	602100015	LOT 18	CON 3	CORNWALL
Point of Reception	Y	602090054	LOT 18	CON 4	CORNWALL
Commercial	Y	602200145	LOT 18	CON 4	CORNWALL
Point of Reception	Y	602100021	LOT 18	CON 3	CORNWALL
Point of Reception	Y	602090055	LOT 18	CON 4	CORNWALL
Point of Reception	Y	602090056	LOT 18	CON 4	CORNWALL
Commercial	Y	602090056	LOT 18	CON 4	CORNWALL
Point of Reception	Y	602090057	LOT 18	CON 4	CORNWALL
Commercial	N	602200143	LOT 18	CON 4	CORNWALL
Commercial	N	602200143	LOT 18	CON 4	CORNWALL
Point of Reception	Y	602200142	LOT 18	CON 4	CORNWALL
Point of Reception	Y	602100024	LOT 18	CON 3	CORNWALL
Commercial	N	602200143	LOT 18	CON 4	CORNWALL
Point of Reception	Y	602090058	LOT 17	CON 4	CORNWALL
Vacant Point of Reception	Y	602200141	LOT 18	CON 4	CORNWALL
Commercial	Y	602100065	LOT 16	CON 3	CORNWALL
Point of Reception	Y	602200140	LOT 18	CON 4	CORNWALL
Vacant Point of Reception	Y	602090081	LOT 17	CON 4	CORNWALL
Point of Reception	Y	602100042	LOT 17	CON 3	CORNWALL
Point of Reception	Y	602100063	LOT 17	CON 3	CORNWALL
Point of Reception	Y	602090083	LOT 17	CON 4	CORNWALL
Vacant Point of Reception	Y	602200139	LOT 18	CON 4	CORNWALL
Point of Reception	Y	602100067	LOT 16	CON 3	CORNWALL
Point of Reception	Y	602090084	LOT 17	CON 4	CORNWALL
Commercial	Y	602090082	LOT 17	CON 4	CORNWALL
Point of Reception	Y	602090085	LOT 17	CON 4	CORNWALL
Point of Reception	Y	602100064	LOT 17	CON 3	CORNWALL
Point of Reception	Y	602090086	LOT 17	CON 4	CORNWALL
Vacant Point of Reception	Y	602100062	LOT 17	CON 3	CORNWALL
Vacant Point of Reception	Y	602090087	LOT 17	CON 4	CORNWALL
Point of Reception	Y	602090088	LOT 17	CON 4	CORNWALL
Point of Reception	Y	602090089	LOT 17	CON 4	CORNWALL
Point of Reception	Y	602100067	LOT 16	CON 3	CORNWALL
Vacant Point of Reception	Y	602200138	LOT 18	CON 4	CORNWALL
Vacant Point of Reception	Y	602090091	LOT 16	CON 4	CORNWALL
Point of Reception	Y	602100066	LOT 16	CON 3	CORNWALL
Commercial	Y	602200137	LOT 18	CON 4	CORNWALL
Point of Reception	Y	602200135	LOT 18	CON 4	CORNWALL
Vacant Point of Reception	Y	602090092	LOT 16	CON 4	CORNWALL
Commercial	N	602090082	LOT 17	CON 4	CORNWALL
Point of Reception	Y	602090110	LOT 15	CON 4	CORNWALL
Commercial	N	602090082	LOT 17	CON 4	CORNWALL
Commercial	N	602090082	LOT 17	CON 4	CORNWALL
Point of Reception	Y	602090059	LOT 18	CON 4	CORNWALL
Commercial	N	602090082	LOT 17	CON 4	CORNWALL
Commercial	N	602090082	LOT 17	CON 4	CORNWALL
Point of Reception	Y	602200164	LOT 22	CON 4	CORNWALL
Point of Reception	Y	602200103	LOT 22	CON 4	CORNWALL
Point of Reception	Y	602200134	LOT 18	CON 4	CORNWALL
Point of Reception	Y	602090061	LOT 18	CON 4	CORNWALL
Point of Reception	Y	602200164	LOT 22	CON 4	CORNWALL
Point of Reception	Y	602200104	LOT 22	CON 4	CORNWALL
Point of Reception	Y	602200133	LOT 18	CON 4	CORNWALL
Point of Reception	Y	602090078	LOT 17	CON 4	CORNWALL
Point of Reception	Y	602200131	LOT 18	CON 4	CORNWALL
Point of Reception	Y	602200129	LOT 18	CON 4	CORNWALL
Commercial	Y	602090082	LOT 17	CON 4	CORNWALL
Vacant Point of Reception	Y	602200165	LOT 21	CON 4	CORNWALL
Point of Reception	Y	602200128	LOT 18	CON 4	CORNWALL
Point of Reception	Y	602090079	LOT 17	CON 4	CORNWALL
Point of Reception	Y	602200126	LOT 18	CON 4	CORNWALL
Vacant Point of Reception	Y	601390321	LOT 22	CON 5	CORNWALL
Point of Reception	Y	601390347	LOT 22	CON 5	CORNWALL
Point of Reception	Y	602200126	LOT 18	CON 4	CORNWALL
Vacant Point of Reception	Y	602090093	LOT 16	CON 4	CORNWALL
Point of Reception	Y	601390346	LOT 22	CON 5	CORNWALL
Vacant Point of Reception	Y	602090410	LOT 16	CON 4	CORNWALL
Point of Reception	Y	602200109	LOT 21	CON 4	CORNWALL
Point of Reception	Y	601390231	LOT 22	CON 5	CORNWALL
Point of Reception	Y	602200125	LOT 18	CON 4	CORNWALL
Point of Reception	N	602090095	LOT 16	CON 4	CORNWALL
Point of Reception	Y	601390232	LOT 22	CON 5	CORNWALL
Point of Reception	Y	602200108	LOT 21	CON 4	CORNWALL
Commercial	Y	602200124	LOT 18	CON 4	CORNWALL
Vacant Point of Reception	Y	602200110	LOT 21	CON 4	CORNWALL
Vacant Point of Reception	Y	602090080	LOT 17	CON 4	CORNWALL
Point of Reception	Y	602200124	LOT 18	CON 4	CORNWALL
Point of Reception	Y	602200123	LOT 18	CON 4	CORNWALL
Vacant Point of Reception	Y	601390243	LOT 21	CON 5	CORNWALL
Vacant Point of Reception	Y	602200114	LOT 20	CON 4	CORNWALL
Vacant Point of Reception	Y	602090420	LOT 17	CON 4	CORNWALL
Point of Reception	Y	602200122	LOT 18	CON 4	CORNWALL



- Legend**
- Point of Common Coupling
  - Point of Interconnection
  - Connection Line
  - Project Location
  - 300 m Buffer of Project Location
  - Distribution Line (HONI)
  - Expressway / Highway
  - Major Road
  - Minor Road
  - Railway
  - Hydro Line
  - Other Transmission Line
  - Pipeline
  - Property Boundary and PIN
  - Water Body

The Project Location is located within an active agricultural area (corn in 2015) and is not located within a natural feature. The Project Location is not located within 50 m of a Provincial Park, Conservation Reserve, or an Area of Natural and Scientific Interest (ANSI).

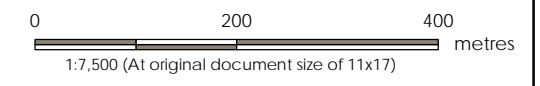

- Notes**
- Coordinate System: NAD 1983 UTM Zone 18N
  - Base features and aerial imagery produced under license with the Ontario Ministry of Natural Resources and Forestry © Queen's Printer for Ontario, 2016. Base data modified by Stantec.



Project Location: 160950879 REV B  
 United Counties of Stormont, Dundas and Glengarry Prepared by AMW on 2016-07-08  
 Technical Review by XX on yyyy-mm-dd  
 Independent Review by XX on yyyy-mm-dd

Client/Project: BARLOW ENERGY CENTRE LIMITED PARTNERSHIP  
 BARLOW SOLAR ENERGY CENTRE

Figure No. **1** **DRAFT**

Title: Barlow Solar Energy Centre  
 Project Location

W:\Active\160950879\Drawings\MXD\APC\ReportFigures\FDR\160950879\_P\ProjectLocation\_20160707.mxd Revised: 2016-07-08 By: awwhite



Stantec Consulting Ltd.  
100-300 Hagey Boulevard, Waterloo ON N2L 0A4

August 26, 2016  
File: 160950879

**Attention: Manon Levesque, Deputy City Clerk**  
City of Cornwall  
360 Pitt Street, Box 877  
Cornwall, ON K6H 5T9

Dear Manon Levesque,

**Reference: Barlow Solar Energy Centre – Request for Approvals under section 41 of the *Planning Act***

Barlow Energy Centre Limited Partnership is proposing to develop, construct, and operate a 10 megawatt alternating current solar energy generating facility, known as the Barlow Solar Energy Centre (the Project), in the Township of South Stormont (within the United Counties of Stormont, Dundas and Glengarry) and the City of Cornwall. The Project was awarded a power purchase contract with the Independent Electricity System Operator (IESO) in March 2016. The Project now requires a Renewable Energy Approval (REA) as per Ontario Regulation 359/09 (as amended May 2016) (O. Reg. 359/09) - under Part V.0.1 of the *Environmental Protection Act*.

On behalf of the Proponent, and as per O. Reg. 359/09, Section 1 (4.1), we are writing to formally request a copy of each approval issued under section 41 of the *Planning Act* by the Township of Alfred and Plantagenet, in respect of a building or structure. Please see the attached Site Plan Approval and Building Permit Request Form, as required under O. Reg. 359/09.

More specifically, we are requesting the following for within the area shown on the attached map:

- Plans of subdivision (approved from 2008 to present);
- Plans of Condominium (approved from 2008 to present); and,
- Severances (approved from 2013 to present).

We are respectfully requesting this information within 60 days from the date of this letter, as per O. Reg. 359/09.

For your information, we have also requested information regarding building permits, minor variances and site plans from the Township of South Stormont.



August 26, 2016  
Manon Levesque, Deputy City Clerk  
Page 2 of 2

**Reference: Barlow Solar Energy Centre – Request for Approvals under section 41 of the *Planning Act***

We look forward to working with you, and obtaining your valuable input, as this project progresses through the regulatory approvals process. Please feel free to contact the undersigned should you require any additional information to assist in providing the above-requested information.

Regards,

**STANTEC CONSULTING LTD.**

Tanya Turk  
Project Manager  
Phone: (905) 415-6416  
Fax: (905)474-9889  
Tanya.Turk@stantec.com

Attachment: Figure 1: Preliminary Project Location  
REA Site Plan Approval and Building Permit Request Form

c. Kevin Campbell, Senior Developer, Barlow Energy Centre Limited Partnership

**From:** [Turk, Tanya](#)  
**To:** [loriann@southstormont.ca](mailto:loriann@southstormont.ca)  
**Cc:** [Kevin Campbell \(Kevin.Campbell@edf-en.ca\)](mailto:Kevin.Campbell@edf-en.ca)  
**Subject:** Site Plan Approval and Building Permit Request - Barlow Solar Energy Centre  
**Date:** Friday, August 26, 2016 3:47:31 PM  
**Attachments:** [160950879\\_ProjectLocation\\_20160707.pdf](#)  
[frm\\_Barlow\\_REA\\_Site\\_Plan\\_Approval\\_and\\_Building\\_Permit\\_Request\\_Form\(2\).pdf](#)  
[20160815\\_160950878\\_Barlow\\_Receptors.xlsx](#)  
[let\\_Township-South-Stormont\\_info-request\\_20160826.pdf](#)

---

Hello Ms. Harbers

Barlow Energy Centre Limited Partnership is proposing to develop, construct, and operate a 10 megawatt alternating current solar energy generating facility, known as the Barlow Solar Energy Centre in the Township of South Stormont (within the United Counties of Stormont, Dundas and Glengarry) and the City of Cornwall. On behalf of Barlow Energy Centre Limited Partnership, and as per O. Reg. 359/09, Section 1 (4.1), we are writing to formally request a copy of each approval issued under section 41 of the Planning Act by the Township of South Stormont, in respect of a building or structure. Please see attached letter, map, receptor list, and Site Plan Approval and Building Permit Request Form, as required under O. Reg. 359/09.

Please do not hesitate to contact me should you have any questions.

**Tanya Turk, M.Sc., P.Ag.**

Project Manager  
Stantec  
300W-675 Cochrane Drive Markham ON L3R 0B8  
Phone: 905-415-6416  
Cell: 416-428-9214  
[tanya.turk@stantec.com](mailto:tanya.turk@stantec.com)

The content of this email is the confidential property of Stantec and should not be copied, modified, retransmitted, or used for any purpose except with Stantec's written authorization. If you are not the intended recipient, please delete all copies and notify us immediately.

 Please consider the environment before printing this email.

Le contenu de ce courriel est la propriété confidentielle de Stantec et ne devrait pas être reproduit, modifié, distribué ou utilisé sans l'autorisation écrite de Stantec. Si vous avez reçu ce message par erreur veuillez supprimer sans délai toutes ses copies et nous en aviser immédiatement.

 Avant d'imprimer ce courriel, réfléchissez à l'impact sur l'environnement.

**Renewable Energy Approval  
Site Plan Approval and Building Permit  
Request Form  
Ontario Regulation 359/09  
Ce formulaire est disponible en français**

This form is intended to standardize the way in which applicants of wind facilities request copies of site plan approvals (issued under section 41 of the *Planning Act*) and building permits (issued under s. 8 of the *Building Code Act*, 1992) from municipalities when they are planning their projects.

Subject to exceptions, site plan approvals and building permits issued in respect of the following land uses are treated as noise receptors for the purposes of the Renewable Energy Approval regulation (O. Reg. 359/09):

1. A building or structure that contains one or more dwellings.
2. A building used for an institutional purpose, including an educational facility, a child care centre, a health care facility, a community centre or a place of worship.

**Municipalities are requested to provide copies of site plan approvals and building permits issued in respect of the above types of land uses. Property addresses have been provided by the applicant in section 2.**

**If a municipality does not provide a copy of each site plan approval or building permit issued in respect of the properties identified below within 60 days of receiving this request, then the proponent of the wind facility may not be required to consider those locations as noise receptors when planning their project and the 550 minimum setback and sound level limits would not apply.**

**Municipalities are requested to return this completed form with copies of requested site plan approvals and/or building permits (if applicable) to the applicant via mail, email, or in person. The applicant's contact information can be found in section 1.**

This form has been approved by the Director for the purpose of s. 1(4.2) of O. Reg. 359/09.

Cette publication hautement spécialisée "Site Plan d'approbation et de permis de construction Formulaire de demande" n'est disponible qu'en anglais conformément au Règlement 671/92, selon lequel il n'est pas obligatoire de la traduire en vertu de la *Loi sur les services en français*. Pour obtenir des renseignements en français, veuillez communiquer avec le ministère Ministère de l'Environnement et de l'Action en matière de changement climatique au 416-314-8001 ou 1-800-461-6290 ou par courriel à [MOE.ServiceIntegration@ontario.ca](mailto:MOE.ServiceIntegration@ontario.ca).

## Section 1 – Renewable Energy Project Description

NOTE: Applicant to complete this section

### Renewable Energy Project Information

Project Name (Project identifier to be used as a reference in correspondence)  
Barlow Solar Energy Centre

#### Project Location

##### Civic Address- Street information

Unit Number	Street Number	Street Name	PO Box
City/Town			Province
			ON - Ontario
			Postal Code

##### Survey Address (Not required if Street Information is provided)

Unit Number	Street Number	Street Name	PO Box
City/Town			Province
T. of South Stormont			ON - Ontario
			Postal Code
Lot	Conc	Part	Reference Plan
20 and 21	4		

Location Information (includes any additional information to clarify physical location e.g. municipality, ward/ township)  
please see attached map for project location.

#### Applicant Contact Information

Last Name	First Name	Middle Initial
Campbell	Kevin	

##### Address

Unit Number	Street Number	Street Name	PO Box
300	53	Jarvis Street	
City/Town			Province
Toronto			ON - Ontario
			Postal Code
			M5C 2H2
Telephone Number	Fax Number	Email Address	
416-216-5053 ext.		Kevin.Campbell@edf-en.ca	

#### Geo Reference (e.g. southwest corner of property)

Map Datum	Zone	Accuracy Estimate
NAD83	18	Teranet spec. estimate w/in 10 m
Geo Referencing Method	UTM Easting	UTM Northing
none (data from FBS projected)	514596	4987701

#### Non Address Information

(where the project spans many locations or a large rural area, specify how the project area relates to the address provided)  
The Project is located in the Township of South Stormont within the United Counties of Stormont, Dundas and Glengarry. It is situated on two parcels of privately-owned land, totaling approximately 94 ha, on the north side of Cornwall Centre Road, west of Power Dam Drive.



**Section 2 – Specific Information Requested**

**NOTE: Applicant and municipality or local authority to complete this section**

**Individual Property / Lot Search:** Applicant to identify addresses of surrounding properties for which they are seeking copies of site plans or building permits.

Applicant to complete information below (attach additional pages of information as required):		Municipality or local authority to complete information below:
Address / Lot #	Description of Property for which information is being sought (if necessary)	Has a site plan approval or building permit been issued in respect of the buildings or structures described above at this property?
See attached excel table.		<input type="checkbox"/> Yes (If yes, municipality to provide copy of approval or building permit) <input type="checkbox"/> No
		<input type="checkbox"/> Yes (If yes, municipality to provide copy of approval or building permit) <input type="checkbox"/> No
		<input type="checkbox"/> Yes (If yes, municipality to provide copy of approval or building permit) <input type="checkbox"/> No
		<input type="checkbox"/> Yes (If yes, municipality to provide copy of approval or building permit) <input type="checkbox"/> No
		<input type="checkbox"/> Yes (If yes, municipality to provide copy of approval or building permit) <input type="checkbox"/> No
		<input type="checkbox"/> Yes (If yes, municipality to provide copy of approval or building permit) <input type="checkbox"/> No
		<input type="checkbox"/> Yes (If yes, municipality to provide copy of approval or building permit) <input type="checkbox"/> No
		<input type="checkbox"/> Yes (If yes, municipality to provide copy of approval or building permit) <input type="checkbox"/> No
		<input type="checkbox"/> Yes (If yes, municipality to provide copy of approval or building permit) <input type="checkbox"/> No
		<input type="checkbox"/> Yes (If yes, municipality to provide copy of approval or building permit) <input type="checkbox"/> No
		<input type="checkbox"/> Yes (If yes, municipality to provide copy of approval or building permit) <input type="checkbox"/> No
		<input type="checkbox"/> Yes (If yes, municipality to provide copy of approval or building permit) <input type="checkbox"/> No
		<input type="checkbox"/> Yes (If yes, municipality to provide copy of approval or building permit) <input type="checkbox"/> No
		<input type="checkbox"/> Yes (If yes, municipality to provide copy of approval or building permit) <input type="checkbox"/> No

Address / Lot #	Description of Property for which information is being sought (if necessary)	Has a site plan approval or building permit been issued in respect of the buildings or structures described above at this property?
		<input type="checkbox"/> Yes (If yes, municipality to provide copy of approval or building permit) <input type="checkbox"/> No
		<input type="checkbox"/> Yes (If yes, municipality to provide copy of approval or building permit) <input type="checkbox"/> No
		<input type="checkbox"/> Yes (If yes, municipality to provide copy of approval or building permit) <input type="checkbox"/> No
		<input type="checkbox"/> Yes (If yes, municipality to provide copy of approval or building permit) <input type="checkbox"/> No
		<input type="checkbox"/> Yes (If yes, municipality to provide copy of approval or building permit) <input type="checkbox"/> No
		<input type="checkbox"/> Yes (If yes, municipality to provide copy of approval or building permit) <input type="checkbox"/> No

---

**Section 3 – Municipality or Local Authority Contact Information**

---

**NOTE: Municipality or local authority to complete this section****Municipal or local authority Information (complete one of the following sections)**Local Municipality  Yes  No

Name of Municipality

---

**Municipal Contact Name**

Last Name

First Name

---

**Address**

Unit Number

Street Number

Street Name

PO Box

City/Town

Province

Postal Code

Telephone Number

ext.

Fax Number

Email Address

Upper Tier Municipality  Yes  No

Name of Municipality

---

**Municipal Contact Name**

Last Name

First Name

---

**Address**

Unit Number

Street Number

Street Name

PO Box

City/Town

Province

Postal Code

Telephone Number

ext.

Fax Number

Email Address



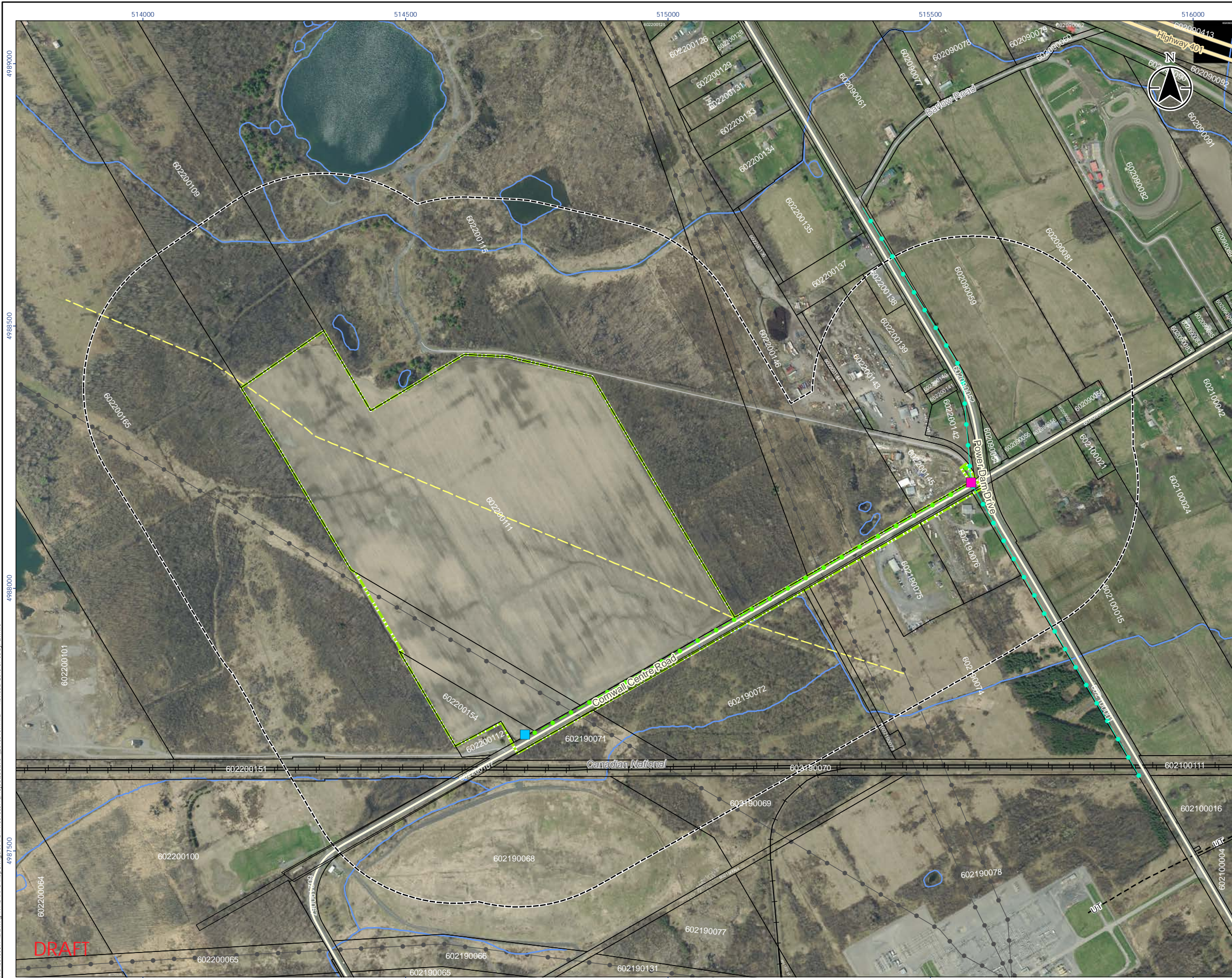

**Legend**

- Point of Common Coupling
- Point of Interconnection
- - - Connection Line
- Project Location
- 300 m Buffer of Project Location
- - - Distribution Line (HONI)
- Expressway / Highway
- Major Road
- Minor Road
- Railway
- Hydro Line
- Other Transmission Line
- Pipeline
- Property Boundary and PIN
- Water Body

The Project Location is located within an active agricultural area (corn in 2015) and is not located within a natural feature. The Project Location is not located within 50 m of a Provincial Park, Conservation Reserve, or an Area of Natural and Scientific Interest (ANSI).

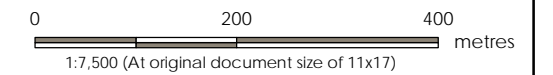

**Notes**

1. Coordinate System: NAD 1983 UTM Zone 18N
2. Base features and aerial imagery produced under license with the Ontario Ministry of Natural Resources and Forestry © Queen's Printer for Ontario, 2016. Base data modified by Stantec.



Project Location: 160950879 REV B  
 United Counties of Stormont, Dundas and Glengarry Prepared by AMW on 2016-07-08  
 Technical Review by XX on yyyy-mm-dd  
 Independent Review by XX on yyyy-mm-dd

Client/Project: BARLOW ENERGY CENTRE LIMITED PARTNERSHIP  
 BARLOW SOLAR ENERGY CENTRE

Figure No. **1** **DRAFT**  
 Title: Barlow Solar Energy Centre  
 Project Location



**Stantec Consulting Ltd.**  
100-300 Hagey Boulevard, Waterloo ON N2L 0A4

August 26, 2016  
File: 160950879

**Attention: Loriann Harbers, Director of Corporate Services/Clerk**  
Township of South Stormont  
2 Mille Roches Road  
P.O. Box 84  
Long Sault, ON K0C 1P0

Dear Ms. Harbers,

**Reference: Barlow Solar Energy Centre – Request for Approvals under section 41 of the *Planning Act***

Barlow Energy Centre Limited Partnership is proposing to develop, construct, and operate a 10 megawatt alternating current solar energy generating facility, known as the Barlow Solar Energy Centre (the Project), in the Township of South Stormont (within the United Counties of Stormont, Dundas and Glengarry) and the City of Cornwall. The Project was awarded a power purchase contract with the Independent Electricity System Operator (IESO) in March 2016. The Project now requires a Renewable Energy Approval (REA) as per Ontario Regulation 359/09 (as amended May 2016) (O. Reg. 359/09) - under Part V.0.1 of the *Environmental Protection Act*.

On behalf of the Proponent, and as per O. Reg. 359/09, Section 1 (4.1), we are writing to formally request a copy of each approval issued under section 41 of the *Planning Act* by the Township of Alfred and Plantagenet, in respect of a building or structure. Please see the attached Site Plan Approval and Building Permit Request Form, as required under O. Reg. 359/09.

More specifically, we are requesting the following for within the area shown on the attached map:

- Plans of subdivision (approved from 2008 to present);
- Plans of Condominium (approved from 2008 to present); and,
- Severances (approved from 2013 to present).

We are respectfully requesting this information within 60 days from the date of this letter, as per O. Reg. 359/09.

For your information, we have also requested information regarding building permits, minor variances and site plans from the City of Cornwall.



August 26, 2016  
Loriann Harbers, Director of Corporate Services/Clerk  
Page 2 of 2

**Reference: Barlow Solar Energy Centre – Request for Approvals under section 41 of the *Planning Act***

We look forward to working with you, and obtaining your valuable input, as this project progresses through the regulatory approvals process. Please feel free to contact the undersigned should you require any additional information to assist in providing the above-requested information.

Regards,

**STANTEC CONSULTING LTD.**

Tanya Turk  
Project Manager  
Phone: (905) 415-6416  
Fax: (905)474-9889  
Tanya.Turk@stantec.com

Attachment: Figure 1: Preliminary Project Location  
REA Site Plan Approval and Building Permit Request Form

c. Kevin Campbell, Senior Developer, Barlow Energy Centre Limited Partnership

**From:** [Turk, Tanya](#)  
**To:** [loriann@southstormont.ca](mailto:loriann@southstormont.ca)  
**Subject:** RE: Site Plan Approval and Building Permit Request - Barlow Solar Energy Centre  
**Date:** Wednesday, August 31, 2016 8:42:31 AM  
**Attachments:** [frm\\_Barlow\\_REA\\_Site Plan Approval and Building Permit Request Form\(2\).pdf](#)

---

Hello Ms. Harbers

Just a note that the form I sent you last week incorrectly stated that the project location is 94 ha, when in fact it is approximately 94 acres. My apologies for the inconvenience. I have attached an updated form for you.

Thanks,

**Tanya Turk, M.Sc., P.Ag.**

Project Manager  
Stantec  
300W-675 Cochrane Drive Markham ON L3R 0B8  
Phone: 905-415-6416  
Cell: 416-428-9214  
[tanya.turk@stantec.com](mailto:tanya.turk@stantec.com)

The content of this email is the confidential property of Stantec and should not be copied, modified, retransmitted, or used for any purpose except with Stantec's written authorization. If you are not the intended recipient, please delete all copies and notify us immediately.

 Please consider the environment before printing this email.

Le contenu de ce courriel est la propriété confidentielle de Stantec et ne devrait pas être reproduit, modifié, distribué ou utilisé sans l'autorisation écrite de Stantec. Si vous avez reçu ce message par erreur veuillez supprimer sans délai toutes ses copies et nous en aviser immédiatement.

 Avant d'imprimer ce courriel, réfléchissez à l'impact sur l'environnement.

---

**From:** Turk, Tanya  
**Sent:** Friday, August 26, 2016 3:47 PM  
**To:** [loriann@southstormont.ca](mailto:loriann@southstormont.ca)  
**Cc:** Kevin Campbell (Kevin.Campbell@edf-en.ca)  
**Subject:** Site Plan Approval and Building Permit Request - Barlow Solar Energy Centre

Hello Ms. Harbers

Barlow Energy Centre Limited Partnership is proposing to develop, construct, and operate a 10 megawatt alternating current solar energy generating facility, known as the Barlow Solar Energy Centre in the Township of South Stormont (within the United Counties of Stormont, Dundas and Glengarry) and the City of Cornwall. On behalf of Barlow Energy Centre Limited Partnership, and as per O. Reg. 359/09, Section 1 (4.1), we are writing to formally request a copy of each approval issued under section 41 of the Planning Act by the Township of South Stormont, in respect of a building or structure. Please see attached letter, map, receptor list, and Site Plan Approval and Building Permit Request Form, as required under O. Reg. 359/09.

Please do not hesitate to contact me should you have any questions.

**Tanya Turk, M.Sc., P.Ag.**

Project Manager  
Stantec  
300W-675 Cochrane Drive Markham ON L3R 0B8  
Phone: 905-415-6416  
Cell: 416-428-9214  
[tanya.turk@stantec.com](mailto:tanya.turk@stantec.com)





Stantec Consulting Ltd.  
100-300 Hagey Boulevard, Waterloo ON N2L 0A4

September 2, 2016  
File: 160950879

**Attention: Helen Thomson & Benjamin De Haan**  
United Counties of Stormont, Dundas & Glengarry  
26 Pitt Street  
Cornwall, Ontario K6J 3P2

Dear Helen & Benjamin,

**Reference: Barlow Solar Energy Centre – Request for Approvals under section 41 of the *Planning Act***

Barlow Energy Centre Limited Partnership is proposing to develop, construct, and operate a 10 megawatt alternating current solar energy generating facility, known as the Barlow Solar Energy Centre (the Project), in the Township of South Stormont (within the United Counties of Stormont, Dundas and Glengarry) and the City of Cornwall. The Project was awarded a power purchase contract with the Independent Electricity System Operator (IESO) in March 2016. The Project now requires a Renewable Energy Approval (REA) as per Ontario Regulation 359/09 (as amended May 2016) (O. Reg. 359/09) - under Part V.0.1 of the *Environmental Protection Act*.

On behalf of the Proponent, and as per O. Reg. 359/09, Section 1 (4.1), we are writing to formally request a copy of each approval issued under section 41 of the *Planning Act* by the United Counties of Stormont, Dundas & Glengarry, in respect of a building or structure. Please see the attached Site Plan Approval and Building Permit Request Form, as required under O. Reg. 359/09.

More specifically, we are requesting the following for within the area shown on the attached map:

- Plans of subdivision (approved from 2008 to present);
- Plans of Condominium (approved from 2008 to present); and,
- Severances (approved from 2013 to present).

We are respectfully requesting this information within 60 days from the date of this letter, as per O. Reg. 359/09.

For your information, we have also requested information regarding building permits, minor variances and site plans from the City of Cornwall.



September 2, 2016  
Helen Thomson & Benjamin De Haan  
Page 2 of 2

**Reference: Barlow Solar Energy Centre – Request for Approvals under section 41 of the *Planning Act***

We look forward to working with you, and obtaining your valuable input, as this project progresses through the regulatory approvals process. Please feel free to contact the undersigned should you require any additional information to assist in providing the above-requested information.

Regards,

**STANTEC CONSULTING LTD.**

A handwritten signature in black ink that reads "Tanya Turk". The signature is written in a cursive, flowing style.

Tanya Turk  
Project Manager  
Phone: (905) 415-6416  
Fax: (905)474-9889  
Tanya.Turk@stantec.com

Attachment: Figure 1: Preliminary Project Location  
REA Site Plan Approval and Building Permit Request Form

c. Kevin Campbell, Senior Developer, Barlow Energy Centre Limited Partnership



- Legend**
- Point of Common Coupling
  - Point of Interconnection
  - Connection Line
  - Project Location
  - 300 m Buffer of Project Location
  - Distribution Line (HONI)
  - Expressway / Highway
  - Major Road
  - Minor Road
  - Railway
  - Hydro Line
  - Other Transmission Line
  - Pipeline
  - Property Boundary and PIN
  - Water Body

The Project Location is located within an active agricultural area (corn in 2015) and is not located within a natural feature. The Project Location is not located within 50 m of a Provincial Park, Conservation Reserve, or an Area of Natural and Scientific Interest (ANSI).

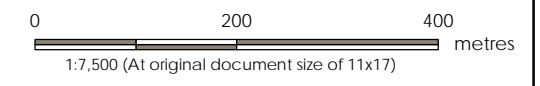

- Notes**
1. Coordinate System: NAD 1983 UTM Zone 18N
  2. Base features and aerial imagery produced under license with the Ontario Ministry of Natural Resources and Forestry © Queen's Printer for Ontario, 2016. Base data modified by Stantec.



Project Location: 160950879 REV B  
 United Counties of Stormont, Dundas and Glengarry Prepared by AMW on 2016-07-08  
 Technical Review by XX on yyyy-mm-dd  
 Independent Review by XX on yyyy-mm-dd

Client/Project: BARLOW ENERGY CENTRE LIMITED PARTNERSHIP  
 BARLOW SOLAR ENERGY CENTRE

Figure No. **1** **DRAFT**  
 Title: Barlow Solar Energy Centre  
 Project Location

W:\Active\160950879\Drawings\MXD\APC\ReportFigures\FDR\160950879\_P\ProjectLocation\_20160707.mxd Revised: 2016-07-08 By: awwhite

**DRAFT**

**From:** [Turk, Tanya](mailto:Turk.Tanya)  
**To:** [b\\_dehaan@sdgcounties.ca](mailto:b_dehaan@sdgcounties.ca); [hthomson@sdgcounties.ca](mailto:hthomson@sdgcounties.ca)  
**Subject:** Barlow Solar Energy Centre  
**Date:** Friday, September 02, 2016 2:17:50 PM  
**Attachments:** [160950879\\_NOC\\_Notice\\_201608.pdf](#)  
[MCF\\_Barlow.pdf](#)  
[20160824\\_News\\_BAR\\_1\\_Final\\_\(2\).pdf](#)  
[let\\_UnitedSDG\\_info-request\\_20160902.pdf](#)  
[frm\\_Barlow\\_REA\\_Site\\_Plan\\_Approval\\_and\\_Building\\_Permit\\_Request\\_Form\(2\).pdf](#)  
[20160815\\_160950878\\_Barlow\\_Receptors.xlsx](#)

---

Hello!

On March 9, 2016, the Barlow Energy Centre Limited Partnership was awarded a contract by the Independent Electricity System Operator for the proposed Barlow Solar Energy Centre (the Project). The Project is located in the Township of South Stormont (within the United Counties of Stormont, Dundas and Glengarry) and the City of Cornwall. Barlow Energy Centre Limited Partnership is now seeking Renewable Energy Approval (REA) for the Project by the Ministry of the Environment and Climate Change as per Ontario Regulation 359/09 (the Regulation) - under Part V.0.1 of the *Environmental Protection Act*. If approved, the Project will have a total maximum name plate capacity of 10 megawatts and will be a Class 3 Solar Facility according to the provisions of the Regulation.

On behalf of Barlow Energy Centre Limited Partnership, please find attached a copy of the combined Notice of Proposal to Engage in a Renewable Energy Project and Notice of Public Meeting. A newsletter to provide a brief project update is also enclosed. In accordance with the Regulation, the first Public Meeting is scheduled for October 5<sup>th</sup> and 6<sup>th</sup>, 2016 to provide an overview of the Project components, activities and potential environmental impacts, and to allow for the exchange of information with the public. A hard copy of the attached Notice, Newsletter and Draft Project Description Report (Draft PDR) was couriered to the Director of Council Services/Clerk (Helen Thomson) today. The Draft PDR will be made available at the Public Meeting, and can also be viewed on the project website at [www.edf-en.ca/projects/project\\_display/barlow-solar-energy-centre1](http://www.edf-en.ca/projects/project_display/barlow-solar-energy-centre1).

As required by the Regulation, a Municipal Consultation Form for the Project is attached. The consultation form is provided for the purpose of consulting on matters relating to municipal or local infrastructure and servicing, and will form the basis of our discussions surrounding the Project. As we progress through the REA process, additional project details (e.g., layout, technical reports, permit requirements) will be developed, provided, and confirmed in consultation with local lower- and upper-tier municipalities.

As per O. Reg. 359/09, Section 1 (4.1), we are also writing to formally request a copy of each approval issued under section 41 of the Planning Act by the United Counties of Stormont, Dundas & Glengarry, in respect of a building or structure. Please see attached letter, map, receptor list, and Site Plan Approval and Building Permit Request Form, as required under O. Reg. 359/09.

We look forward to working with you, and obtaining your valuable input as this project progresses through the regulatory approvals process. We hope that you will attend the Public Meeting described in the attached notice. To submit written comments on the Draft PDR or to seek further information on the Project, please contact the undersigned and / or refer to the contact information below.

Kevin Campbell, Senior Developer  
Barlow Energy Centre Limited Partnership  
53 Jarvis Street, Ste. 300, Toronto, ON M5C 2H2  
Phone: (416) 216-5053

Email: [Kevin.Campbell@edf-en.ca](mailto:Kevin.Campbell@edf-en.ca)

Thank you,

**Tanya Turk, M.Sc., P.Ag.**

Project Manager

Stantec

300W-675 Cochrane Drive Markham ON L3R 0B8

Phone: 905-415-6416

Cell: 416-428-9214

[tanya.turk@stantec.com](mailto:tanya.turk@stantec.com)

The content of this email is the confidential property of Stantec and should not be copied, modified, retransmitted, or used for any purpose except with Stantec's written authorization. If you are not the intended recipient, please delete all copies and notify us immediately.



Please consider the environment before printing this email.

Le contenu de ce courriel est la propriété confidentielle de Stantec et ne devrait pas être reproduit, modifié, distribué ou utilisé sans l'autorisation écrite de Stantec. Si vous avez reçu ce message par erreur veuillez supprimer sans délai toutes ses copies et nous en aviser immédiatement.



Avant d'imprimer ce courriel, réfléchissez à l'impact sur l'environnement.

# NOTICE OF A PROPOSAL TO ENGAGE IN A RENEWABLE ENERGY PROJECT AND NOTICE OF PUBLIC MEETING

## To be held by Barlow Energy Centre Limited Partnership regarding a Proposal to Engage in a Renewable Energy Project

**Project Name:** Barlow Solar Energy Centre (the Project)

**Project Location:** The Project is located approximately 10 km west of the City centre of Cornwall, on two parcels of privately-owned land on the north side of Cornwall Centre Road, west of Power Dam Drive. The connection line would run approximately 1 km east along Cornwall Centre Road.

**Dated at** the Township of South Stormont within the United Counties of Stormont, Dundas and Glengarry, and the City of Cornwall, on this the first of September, 2016.

Barlow Energy Centre Limited Partnership is planning to engage in a renewable energy project in respect of which the issuance of a renewable energy approval is required. The distribution of this combined Notice of a Proposal to Engage in a Renewable Energy Project and Notice of Public Meeting, and the Project itself are subject to the provisions of the Environmental Protection Act (the Act) Part V.0.1 and Ontario Regulation 359/09 (the Regulation). This Notice must be distributed in accordance with section 15 of the Regulation prior to an application being submitted and assessed for completeness by the Ministry of the Environment and Climate Change.

**Project Description:**

Pursuant to the Act and Regulation, the facility, in respect of which the project is to be engaged in, is considered to be a Class 3 Solar Facility. If approved, this facility would have a total maximum name plate capacity of 10 MW. The project location is described in the map to the right.

**Documents for Public Inspection:**

The Project is being proposed in accordance with the requirements of the Act and Regulation. The Draft Project Description Report titled Pendleton Solar Energy Centre – Draft Project Description Report describes the facility as a solar energy generating facility that will be used to convert solar energy to electricity. A written copy of the Draft Project Description Report has been made available for public inspection during regular business hours at the Township of South Stormont municipal office (2 Mille Roches Road, Long Sault) as well as the City of Cornwall municipal office (360 Pitt Street, Cornwall) and online at [www.edf-en.ca/projects/project\\_display/barlow-solar-energy-centre1](http://www.edf-en.ca/projects/project_display/barlow-solar-energy-centre1). The Draft Project Description Report will also be made available at the public meeting, described below.

**Public Meeting Information:**

A Public Meeting is being held, and stakeholder input collected, as part of the above-noted regulatory process. The meeting will provide the community with the opportunity to meet the Project team, learn more about the proposed Project and the regulatory process, and provide comments and questions regarding the Project. We would appreciate your input and welcome your attendance at our drop-in style meeting.

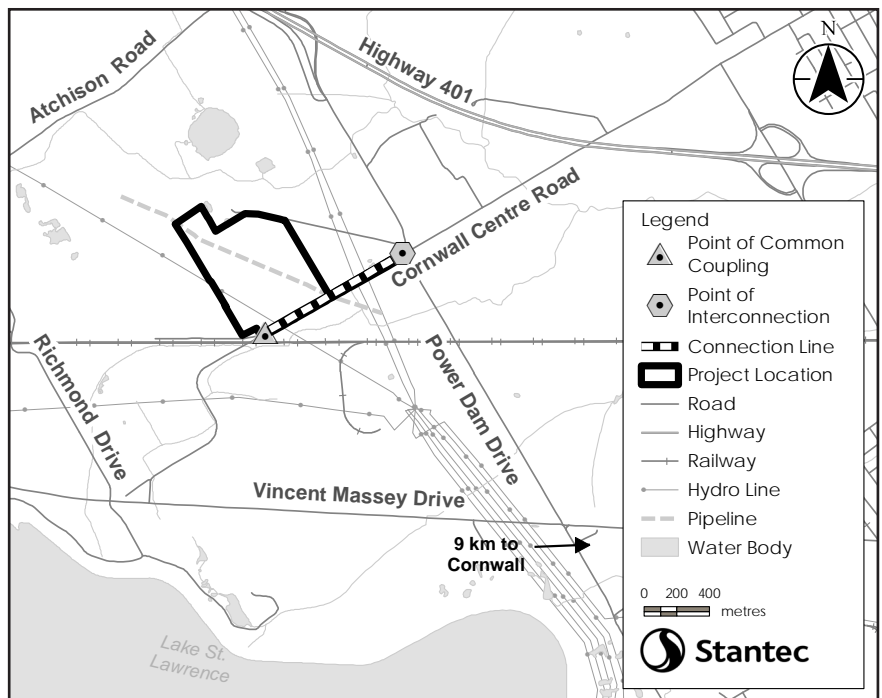

	Date	Wednesday October 5, 2016	Thursday October 6, 2016
<b>Public Meeting Locations</b>	<b>Time</b>	5:00 p.m. – 8:00 p.m.	5:00 p.m. – 8:00 p.m.
	<b>Place</b>	South Stormont Community Hall 2 Mille Roches Road, Long Sault	Best Western Parkway Inn & Conference Centre 1515 Vincent Massey Drive, Cornwall

**Project Contacts and Information:**

To learn more about the project proposal, public meeting, or to communicate concerns please refer to the contact information below.

Project Email Address: [BarlowSolar@edf-en.ca](mailto:BarlowSolar@edf-en.ca)  
 Toll-Free Phone Number: 1-844-55-EDF-EN  
 Project Website: [www.edf-en.ca/projects/project\\_display/barlow-solar-energy-centre1](http://www.edf-en.ca/projects/project_display/barlow-solar-energy-centre1)

**Fabiola Oribe**, Associate Project Developer and Stakeholder Relations  
 Pendleton Energy Centre Limited Partnership  
 53 Jarvis Street, Ste. 300, Toronto, ON M5C 2H2  
 Phone Number: 877.697.9997 (ext. 4146)

The Barlow Newsletter is designed to provide you with the latest information about the Barlow Solar Energy Centre. This publication will help you learn about the project, its timelines, anticipated benefits and provide project contact information.

## ABOUT THE PROJECT

Selected by the Independent Electricity System Operator (IESO) under the Large Renewable Procurement I Request for Proposals ("LRP I RFP"), Barlow Solar Energy Centre is being realized by a partnership between EDF EN Canada and the Algonquins of Pikwàkanagàn First Nation.

The project will be situated on privately-owned land located within the Township of South Stormont and

utilize a right of way within the City of Cornwall to connect to the existing electricity distribution grid. Barlow Solar Energy Centre will have a capacity of 10 megawatts alternating current (MWac) and will generate enough power to meet the demand of about 2,000 homes.

Construction is planned for 2018, following the receipt of required provincial and municipal approvals and permits. Commercial operation is expected by the end of 2018.

## COMMUNITY BENEFITS

**The Township of South Stormont, county, as well as associated school boards and local residents will realize many benefits, including:**

- A Community Benefit Agreement to contribute funds on an annual basis to the Township of South Stormont for improving local infrastructure and services (nearly \$480,000 over the life of the project).
- Additional property tax revenues generated by the project that will help to supplement revenues for the Township of South Stormont, county and local school boards (nearly \$400,000 over the life of the project).
- Nearly one hundred (100) construction jobs at the peak of construction, providing opportunities for local employment and the hospitality sector.
- Important opportunities for the local and surrounding economy during construction through: the procurement of local services, contractors and materials for project construction (i.e. aggregate, landscaping, etc.).

## PROJECT TIMELINE

\*MOECC - Ministry of Environment and Climate Change  
Note: Public consultation continues throughout each phase of the project



# PROJECT STUDIES



SAMPLE OF ARCHAEOLOGICAL FIELD WORK

A number of studies are necessary as part of the approvals and permitting process. The following studies are either complete or underway:

- A natural heritage site investigation to identify if sensitive natural features such as wetlands or significant woodlands exist on or within 50m of the Project Location.
- An aquatic site investigation to identify if aquatic features, such as water bodies or streams, exist within 120 m of the Project Location.
- An archaeology assessment to determine the archaeological potential of the Project Location.
- A review of cultural heritage resources to identify heritage sites within or adjacent to the Project Location.

These studies identify sensitive features and identify mitigation measures to protect these features. No archaeological resources have been recovered during the Stage 2 Archaeology Assessment to date.

The noise assessment is an important study to be conducted later this year to confirm that sound propagating from project equipment during operation is less than 40 dB (equivalent to a quiet room) at the exterior of neighboring homes.

More details will be shared with the public and municipal and provincial agencies in the coming months as we complete our studies and associated reports.



TEST PIT SURVEY

## HOW SOLAR WORKS

- 1 - Energy from the sun falls onto the earth's surface each day in the form of sunlight.
- 2 - The sunlight is absorbed by the solar panel, converting sunlight into electricity.
- 3 and 4 - Electricity generated travels through distribution lines to homes and businesses.

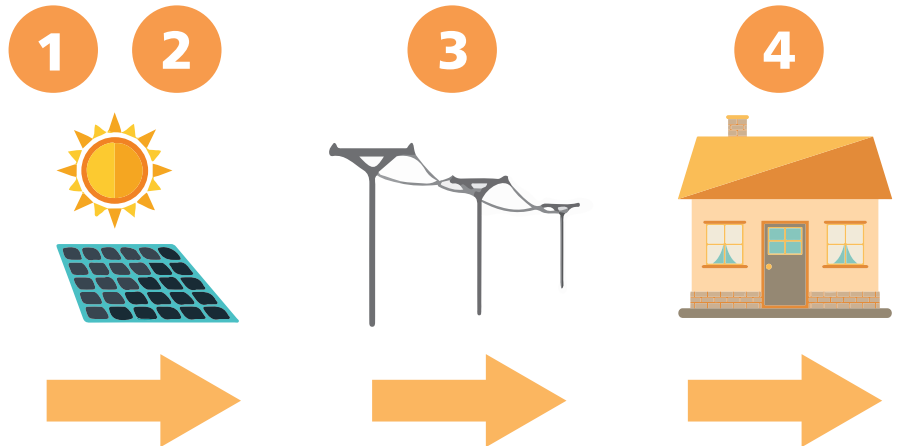

Crédits illustrations: 123rf -Yulia Drozdova; neonicflower

## STAY TUNED!

The second open house for the Barlow Solar Energy Centre is scheduled for Wednesday, October 5th (South Stormont Community Hall) and Thursday, October 6th (Best Western Plus Parkway Cornwall), from 5 PM to 8 PM. This is an opportunity for you to learn more about the solar energy centre and share with us your interests that should be considered during project planning. We encourage you to call or email us to be added to our mailing list, to share your thoughts about the project, or if you have any questions.

The project newsletter and open house details will also be on our website:  
[http://edf-en.ca/projects/project\\_display/barlow-solar-energy-centre1](http://edf-en.ca/projects/project_display/barlow-solar-energy-centre1)

### CONTACT US

Fabiola Oribe, Associate Developer and Stakeholder Relations.

Email: [BarlowSolar@edf-en.ca](mailto:BarlowSolar@edf-en.ca) / Phone: 1-844-55-EDF-EN







**Renewable Energy Approval  
Site Plan Approval and Building Permit  
Request Form**

**Ontario Regulation 359/09**

**Ce formulaire est disponible en français**

This form is intended to standardize the way in which applicants of wind facilities request copies of site plan approvals (issued under section 41 of the *Planning Act*) and building permits (issued under s. 8 of the *Building Code Act*, 1992) from municipalities when they are planning their projects.

Subject to exceptions, site plan approvals and building permits issued in respect of the following land uses are treated as noise receptors for the purposes of the Renewable Energy Approval regulation (O. Reg. 359/09):

1. A building or structure that contains one or more dwellings.
2. A building used for an institutional purpose, including an educational facility, a child care centre, a health care facility, a community centre or a place of worship.

**Municipalities are requested to provide copies of site plan approvals and building permits issued in respect of the above types of land uses. Property addresses have been provided by the applicant in section 2.**

**If a municipality does not provide a copy of each site plan approval or building permit issued in respect of the properties identified below within 60 days of receiving this request, then the proponent of the wind facility may not be required to consider those locations as noise receptors when planning their project and the 550 minimum setback and sound level limits would not apply.**

**Municipalities are requested to return this completed form with copies of requested site plan approvals and/or building permits (if applicable) to the applicant via mail, email, or in person. The applicant's contact information can be found in section 1.**

This form has been approved by the Director for the purpose of s. 1(4.2) of O. Reg. 359/09.

Cette publication hautement spécialisée "Site Plan d'approbation et de permis de construction Formulaire de demande" n'est disponible qu'en anglais conformément au Règlement 671/92, selon lequel il n'est pas obligatoire de la traduire en vertu de la *Loi sur les services en français*. Pour obtenir des renseignements en français, veuillez communiquer avec le ministère Ministère de l'Environnement et de l'Action en matière de changement climatique au 416-314-8001 ou 1-800-461-6290 ou par courriel à [MOE.ServiceIntegration@ontario.ca](mailto:MOE.ServiceIntegration@ontario.ca).

## Section 1 – Renewable Energy Project Description

NOTE: Applicant to complete this section

### Renewable Energy Project Information

Project Name (Project identifier to be used as a reference in correspondence)

Barlow Solar Energy Centre

#### Project Location

##### Civic Address- Street information

Unit Number	Street Number	Street Name	PO Box
City/Town	Province		Postal Code
	ON - Ontario		

##### Survey Address (Not required if Street Information is provided)

Unit Number	Street Number	Street Name	PO Box
City/Town	Province		Postal Code
T. of South Stormont	ON - Ontario		
Lot	Conc	Part	Reference Plan
20 and 21	4		

Location Information (includes any additional information to clarify physical location e.g. municipality, ward/ township)  
please see attached map for project location.

#### Applicant Contact Information

Last Name	First Name	Middle Initial
Campbell	Kevin	

#### Address

Unit Number	Street Number	Street Name	PO Box
300	53	Jarvis Street	
City/Town	Province		Postal Code
Toronto	ON - Ontario		M5C 2H2
Telephone Number	Fax Number	Email Address	
416-216-5053 ext.		Kevin.Campbell@edf-en.ca	

#### Geo Reference (e.g. southwest corner of property)

Map Datum	Zone	Accuracy Estimate
NAD83	18	Teranet spec. estimate w/in 10 m
Geo Referencing Method	UTM Easting	UTM Northing
none (data from FBS projected)	514596	4987701

#### Non Address Information

(where the project spans many locations or a large rural area, specify how the project area relates to the address provided)  
The Project is located in the Township of South Stormont within the United Counties of Stormont, Dundas and Glengarry. It is situated on two parcels of privately-owned land, totaling approximately 94 acres, on the north side of Cornwall Centre Road, west of Power Dam Drive.

**Section 2 – Specific Information Requested**

**NOTE: Applicant and municipality or local authority to complete this section**

**Individual Property / Lot Search:** Applicant to identify addresses of surrounding properties for which they are seeking copies of site plans or building permits.

Applicant to complete information below (attach additional pages of information as required):		Municipality or local authority to complete information below:
Address / Lot #	Description of Property for which information is being sought (if necessary)	Has a site plan approval or building permit been issued in respect of the buildings or structures described above at this property?
See attached excel table.		<input type="checkbox"/> Yes (If yes, municipality to provide copy of approval or building permit) <input type="checkbox"/> No
		<input type="checkbox"/> Yes (If yes, municipality to provide copy of approval or building permit) <input type="checkbox"/> No
		<input type="checkbox"/> Yes (If yes, municipality to provide copy of approval or building permit) <input type="checkbox"/> No
		<input type="checkbox"/> Yes (If yes, municipality to provide copy of approval or building permit) <input type="checkbox"/> No
		<input type="checkbox"/> Yes (If yes, municipality to provide copy of approval or building permit) <input type="checkbox"/> No
		<input type="checkbox"/> Yes (If yes, municipality to provide copy of approval or building permit) <input type="checkbox"/> No
		<input type="checkbox"/> Yes (If yes, municipality to provide copy of approval or building permit) <input type="checkbox"/> No
		<input type="checkbox"/> Yes (If yes, municipality to provide copy of approval or building permit) <input type="checkbox"/> No
		<input type="checkbox"/> Yes (If yes, municipality to provide copy of approval or building permit) <input type="checkbox"/> No
		<input type="checkbox"/> Yes (If yes, municipality to provide copy of approval or building permit) <input type="checkbox"/> No
		<input type="checkbox"/> Yes (If yes, municipality to provide copy of approval or building permit) <input type="checkbox"/> No
		<input type="checkbox"/> Yes (If yes, municipality to provide copy of approval or building permit) <input type="checkbox"/> No
		<input type="checkbox"/> Yes (If yes, municipality to provide copy of approval or building permit) <input type="checkbox"/> No
		<input type="checkbox"/> Yes (If yes, municipality to provide copy of approval or building permit) <input type="checkbox"/> No
		<input type="checkbox"/> Yes (If yes, municipality to provide copy of approval or building permit) <input type="checkbox"/> No

Address / Lot #	Description of Property for which information is being sought (if necessary)	Has a site plan approval or building permit been issued in respect of the buildings or structures described above at this property?
		<input type="checkbox"/> Yes (If yes, municipality to provide copy of approval or building permit) <input type="checkbox"/> No
		<input type="checkbox"/> Yes (If yes, municipality to provide copy of approval or building permit) <input type="checkbox"/> No
		<input type="checkbox"/> Yes (If yes, municipality to provide copy of approval or building permit) <input type="checkbox"/> No
		<input type="checkbox"/> Yes (If yes, municipality to provide copy of approval or building permit) <input type="checkbox"/> No
		<input type="checkbox"/> Yes (If yes, municipality to provide copy of approval or building permit) <input type="checkbox"/> No
		<input type="checkbox"/> Yes (If yes, municipality to provide copy of approval or building permit) <input type="checkbox"/> No

---

**Section 3 – Municipality or Local Authority Contact Information**

---

**NOTE: Municipality or local authority to complete this section****Municipal or local authority Information (complete one of the following sections)**Local Municipality  Yes  No

Name of Municipality

---

**Municipal Contact Name**

Last Name

First Name

---

**Address**

Unit Number

Street Number

Street Name

PO Box

City/Town

Province

Postal Code

Telephone Number

ext.

Fax Number

Email Address

Upper Tier Municipality  Yes  No

Name of Municipality

---

**Municipal Contact Name**

Last Name

First Name

---

**Address**

Unit Number

Street Number

Street Name

PO Box

City/Town

Province

Postal Code

Telephone Number

ext.

Fax Number

Email Address



**Stantec Consulting Ltd.**  
1-70 Southgate Drive  
Guelph ON N1G 4P5  
Phone: (519) 836-6050  
Fax: (519) 836-2493

---

To:	John St. Marseille	From:	Tanya Turk
Company:	City of Cornwall Municipal Office	<input type="checkbox"/>	For Your Information
Address:	360 Pit Street	<input type="checkbox"/>	For Your Approval
Phone:		<input type="checkbox"/>	For Your Review
		<input type="checkbox"/>	As Requested
Date:	February 17, 2017	Confirmation	
File:	160960913	of receipt:	_____
Delivery:	Courier		(signature)

---

**Reference: Barlow Solar Energy Centre**

Attachment:

Copies	Doc Date	Description
1	February 2017	Barlow Solar Energy Centre – Draft REA Documents

Barlow Energy Centre Limited Partnership and the Project Team have prepared this package of draft Renewable Energy Approval (REA) Documents as part of our REA application, in compliance with the requirements of the Environmental Protection Act and Ontario Regulation 359/09. Please make these draft REA Documents, Notice and Newsletter available for public inspection no later than February 22, 2017, as specified in the Notice.

**STANTEC CONSULTING LTD.**



Tanya Turk  
Environmental Scientist  
Phone: (905) 415-6416  
Fax: (905) 474-9889  
Tanya.Turk@stantec.com

**Stantec Consulting Ltd.**  
1-70 Southgate Drive  
Guelph ON N1G 4P5  
Phone: (519) 836-6050  
Fax: (519) 836-2493

---

To:	Loriann Harbers	From:	Tanya Turk
Company:	Township of South Stormont Municipal Office	<input type="checkbox"/>	For Your Information
Address:	2 Mill Roches Road	<input type="checkbox"/>	For Your Approval
Phone:		<input type="checkbox"/>	For Your Review
Date:	February 17, 2017	<input type="checkbox"/>	As Requested
File:	160960913	Confirmation	
Delivery:	Courier	of receipt: _____	(signature)

---

**Reference: Barlow Solar Energy Centre**

Attachment:

Copies	Doc Date	Description
1	February 2017	Barlow Solar Energy Centre - Draft REA Documents

Barlow Energy Centre Limited Partnership and the Project Team have prepared this package of draft Renewable Energy Approval (REA) Documents as part of our REA application, in compliance with the requirements of the Environmental Protection Act and Ontario Regulation 359/09. Please make these draft REA Documents, Notice and Newsletter available for public inspection no later than February 22, 2017, as specified in the Notice.

**STANTEC CONSULTING LTD.**



Tanya Turk  
Environmental Scientist  
Phone: (905) 415-6416  
Fax: (905) 474-9889  
Tanya.Turk@stantec.com



**TOWNSHIP OF SOUTH STORMONT**

**RESOLUTION**

**MOVED BY**

*[Signature]*

**RESOLUTION NO**

107/2017

**SECONDED BY**

*[Signature]*

**DATE** April 12, 2017

That Council directs staff to submit comments on the Barlow Solar Energy Centre Project through the Municipal Consultation Form based on the following principles:

The Township continues to support the Barlow Solar Energy Centre project. The Township requests that EDF-EN Canada voluntarily submit to the Raisin Region Conservation Authority permitting process during the implementation stage of the proposal to permit the roads and structures within the floodplain.

The Township requests that in addition to the proposed screening along Cornwall Centre Road, any shipping containers be screened in accordance with the requirements of Zoning By-law 2011-100.

The Township requests that EDF-EN Canada work closely with the South Stormont Fire Protection Services on the design of access roads, training requirements, the development of a response plan, and a transition plan for any future ownership changes.

CARRIED

DEFEATED

DEFERRED

*[Signature]*

Chairperson

Recorded Vote:

Councillor Primeau	_____
Councillor Smith	_____
Councillor Waldroff	_____
Deputy Mayor Hart	_____
Mayor Bancroft	_____



## Cornwall City Council

**DEPARTMENT:** Department of Infrastructure and Municipal Works  
**REPORT NUMBER:** 2015-IMW-20  
**PREPARED BY:** Mary Fotenas, Administrative Assistant  
**REPORT DATE:** August 20, 2015  
**MEETING DATE:** Aug 24, 2015 06:00 PM - Special  
**SUBJECT:** Barlow Solar Energy Centre

---

### **PURPOSE**

The purpose of this report is to request the adoption of an updated resolution of support for the Barlow Solar Energy Centre project by the Barlow Energy Centre Limited Partnership. They also require two additional resolutions to authorise an agreement and the confirmation that an information meeting was held with Administration.

As a neighbouring municipality, the City of Cornwall is requested to provide a resolution to support the initial application to the Independent Electricity System Operator (IESO) for consideration as a "Large Renewable Energy Project".

### **RECOMMENDATION**

That Council approve the attached resolutions for the Barlow Solar Energy Centre by the The Barlow Energy Centre Limited Partnership for a Large Renewable Project of 12MW Capacity, the operative clauses of which are:

#### **Operative clauses for the Municipal Support resolution:**

Now therefore be it Resolved that:

1. The Council of the City of Cornwall supports the development, construction and operation of the Large Renewable Project and/or proposed Connection Line on the Lands.
2. This resolution's sole purpose is to enable the Registered Proponent to receive

Rated Criteria points under LRP I RFP and may not be used for the purpose of any other form of approval in relation to the Proposal or Large Renewable Project and/or proposed Connection Line or for any other purpose. Rated Criteria points will be used to rank the Registered Proponent's Proposal in relation to other Proposals received by the IESO under the LRP I RFP.

3. Though this resolution may impact the rank of the Registered Proponent's Proposal in relation to other Proposals received by the IESO, it does not guarantee a contract will be offered to the Registered Proponent under the LRP I RFP.

**Operative clauses for the Municipal Agreement Resolution:**

Now therefore be it Resolved that:

1. The Registered Proponent acknowledges that it is proposing to develop, construct and operate a Large Renewable Project with the characteristics outlined in the above under the LRP I RFP.
2. The Local Municipality of City of Cornwall acknowledges that it has entered into a binding agreement with the Registered Proponent in respect of the Large Renewable Project effective on the 24 day of August 2015.
3. The Registered Proponent and the Local Municipality acknowledge that the binding agreement may be conditional only on the Registered Proponent being awarded an LRP I Contract for the Large Renewable Project.
4. The Registered Proponent and the Local Municipality acknowledge that the Registered Proponent's Proposal may be awarded Rated Criteria points by the IESO under the LRP I RFP where the Registered Proponent and every Project Community completes this Prescribed Form.
5. The Registered Proponent acknowledges that the binding agreement may not be used for the purpose of any other form of approval in relation to the Proposal or the large Renewable Project of for any other purpose, and
6. To authorise the Mayor and City Clerk to sign the attached agreement and all necessary documents to fulfil the first application phase.

**Operative clauses for the Municipal Meeting Confirmation Resolution:**

The Local Municipality confirms to the IESO the following:

1. I am the City Clerk of the City of Cornwall (the "Local Municipality") and have

the delegated authority to provide this confirmation on behalf of the Local Municipality and without personal liability.

2. The Registered Proponent has advised the Local Municipality that it proposes to develop, construct and operate a Large Renewable Project and/or proposed Connection Line, with the characteristics outlined in the table above, under the LRP I RFP.

3. On the 11th day of August, 2015, at City Hall in the City of Cornwall, the Registered Proponent held a meeting with representatives of the Local Municipality to discuss the particulars of the Large Renewable Project and/or proposed Connection Line (the "Meeting").

4. Representatives of the Local Municipality that attended the Meeting are listed in Exhibit A. (Norm Levac, Chief Administrative Officer and John St. Marseille, General Manager, Infrastructure & Municipal Works) Local Municipality: City of Cornwall, and

5. That the Mayor and City Clerk be authorized to sign the necessary document.

#### **Location**

All 3 resolutions are for Non-Rooftop Solar Panel which will be located in the Township of South Stormont except for the proposed power connection line which will be located along the north side road allowance, between Concession 3 and Concession 4, of Cornwall Centre Road, running east from the site, to Power Dam Drive.

#### **FINANCIAL IMPLICATIONS**

None. All cost pertaining to this project will be borne by the Registered Proponent.

#### **BACKGROUND / DISCUSSION**

At the Council meeting of August 10, 2015, Council adopted a resolution of support for the Esdale Solar Project by Share-a-watt, for a 10MW project.

#### **Changes required**

The company then met with Administration to discuss a number of project changes, which, in order to comply with the terms of the provincial project to which they are applying, require a new resolution reflecting the changes (registered proponent name, project name, project capacity and route as well as other requirements such as the authorisation of several documents).

The project is now the Barlow Solar Energy Centre by the Barlow Energy Centre Limited Partnership, for a 12 MW project and requires the authorisation of an agreement.

### **Agreement**

The binding agreement stipulates that the City will do its best to cooperate with the Barlow Energy Centre Limited Partnership to help them to achieve their goal.

### **Authorisations**

If the project is approved by IESO as a Large Renewable Energy project, the Registered Proponent would require municipal authorisations to complete the power connection.

### **Project route**

The location is the same but the project route and plan is now to bury a cable along the north side of Cornwall Centre Road to the NW corner of Power Dam Drive. The line will run for approximately 550 metres along the north side of Cornwall Centre Road to the designated tap point on the NW corner of Power Dam Drive and Cornwall Centre Road (inside the City of Cornwall, because the road allowance belongs 100% to the City).

The project is entirely located in the Township of South Stormont except for the power connection line which is proposed on the City-owned Cornwall Centre Road right-of-way (for which a separate, subsequent municipal approval(s) will be required).

### **The detailed project locations and description of the project are:**

Description of the Properties within the geographic bounds of the Local Municipality on which the Site and/or Connection Line is Located <PIN(s):

Firstly: all of that portion of Lot 20 and Lot 21, Con. 4 in the Township of South Stormont as shown on the print of plan 203-9639 attached to instrument #48602, PIN #60220-0111

Secondly: Part of the east half of Lot 21, Con. 4 in the Township of South Stormont as described in instrument #308247, PIN#60220-0154 the Large Renewable Project>(the "Lands").

Thirdly: Part road allowance between Con. 3 and Con.4 Cornwall; part widening on plan 277 between east limit of block A and travelled road abutting Lot 2, PIN#60220-0107 (LT).

The Registered Proponent acknowledges that the Large Renewable Project and/or proposed Connection Line, either in whole or in part is to be located on lands under the jurisdiction of Township of South Stormont, the City of Cornwall (Cornwall Centre Road) and/or Hydro One corridor.

## ATTACHMENTS



site details.pdf



Prescribed-Form-Municipal-Agreement\_Cornwall.docx



20150819 Municipal resolution of support.docx



renewable-energy-development-in-ontario-info-for-municipalities.pdf



20150819 Prescribed Form - Confirmation of a meeting.docx

Motion to approve the attached resolutions for the Barlow Solar Energy Centre by the The Barlow Energy Centre Limited Partnership for a Large Renewable Project of 12MW Capacity, the operative clauses of which are:

### **Operative clauses for the Municipal Support resolution:**

Now therefore be it Resolved that:

1. The Council of the City of Cornwall supports the development, construction and operation of the Large Renewable Project and/or proposed Connection Line on the Lands.
2. This resolution's sole purpose is to enable the Registered Proponent to receive Rated Criteria points under LRP I RFP and may not be used for the purpose of any other form of approval in relation to the Proposal or Large Renewable Project

and/or proposed Connection Line or for any other purpose. Rated Criteria points will be used to rank the Registered Proponent's Proposal in relation to other Proposals received by the IESO under the LRP I RFP.

3. Though this resolution may impact the rank of the Registered Proponent's Proposal in relation to other Proposals received by the IESO, it does not guarantee a contract will be offered to the Registered Proponent under the LRP I RFP.

**Operative clauses for the Municipal Agreement Resolution:**

Now therefore be it Resolved that:

1. The Registered Proponent acknowledges that it is proposing to develop, construct and operate a Large Renewable Project with the characteristics outlined in the above under the LRP I RFP.

2. The Local Municipality of City of Cornwall acknowledges that it has entered into a binding agreement with the Registered Proponent in respect of the Large Renewable Project effective on the 24 day of August 2015.

3. The Registered Proponent and the Local Municipality acknowledge that the binding agreement may be conditional only on the Registered Proponent being awarded an LRP I Contract for the Large Renewable Project.

4. The Registered Proponent and the Local Municipality acknowledge that the Registered Proponent's Proposal may be awarded Rated Criteria points by the IESO under the LRP I RFP where the Registered Proponent and every Project Community completes this Prescribed Form.

5. The Registered Proponent acknowledges that the binding agreement may not be used for the purpose of any other form of approval in relation to the Proposal or the large Renewable Project of for any other purpose, and

6. To authorise the Mayor and City Clerk to sign the attached agreement and all necessary documents to fulfil the first application phase.

**Operative clauses for the Municipal Meeting Confirmation Resolution:**

The Local Municipality confirms to the IESO the following:

1. I am the City Clerk of the City of Cornwall (the "Local Municipality") and have the delegated authority to provide this confirmation on behalf of the Local Municipality and without personal liability.

2. The Registered Proponent has advised the Local Municipality that it proposes to develop, construct and operate a Large Renewable Project and/or proposed Connection Line, with the characteristics outlined in the table above, under the LRP I RFP.

3. On the 11th day of August, 2015, at City Hall in the City of Cornwall, the Registered Proponent held a meeting with representatives of the Local Municipality to discuss the particulars of the Large Renewable Project and/or proposed Connection Line (the "Meeting").

4. Representatives of the Local Municipality that attended the Meeting are listed in Exhibit A. (Norm Levac, Chief Administrative Officer and John St. Marseille, General Manager, Infrastructure & Municipal Works) Local Municipality: City of Cornwall, and

5. That the Mayor and City Clerk be authorized to sign the necessary document.

**Location**

All 3 resolutions are for Non-Rooftop Solar Panel which will be located in the Township of South Stormont except for the proposed power connection line which will be located along the north side road allowance, between Concession 3 and Concession 4, of Cornwall Centre Road, running east from the site, to Power Dam Drive.

Moved By: Justin Towndale, Councillor  
Seconded By: Andre Rivette, Councillor

**Approval**

August 20, 2015 10:04 AM

John St Marseille  
General Manager, Infrastructure and  
Municipal Works

Motion Approved  
  

August 20, 2015 10:13 AM

Helen Finn  
City Clerk



August 20, 2015 03:54 PM

Norm Levac  
Chief Administrative Officer





# APPENDIX F PRE-REA CONSULTATION MATERIALS

## I would like to personally invite you to attend the Public Meeting for the proposed Barlow Solar Energy Centre.

In advance of the meeting I wanted to share with you some key project details:

- EDF EN Canada Development Inc. plans to submit the proposed Barlow Solar Energy Centre into the competitive Large Renewable Procurement (LRP I RFP) process on September 1, 2015;
- The proposed Barlow Solar Energy Centre is in the early stages of planning, therefore all project design and layout information is preliminary;
- EDF EN Canada Development Inc. will host more public meetings as the project planning continues;
- There is no contract yet with the IESO or Ontario government.

EDF EN Canada Development Inc. operates differently than other renewable energy companies, because we not only develop and build renewable projects, but through our operations and maintenance affiliate—EDF Renewable Services, we intend to operate the facility throughout its operational life.

Our long-term approach means we judge success by our ability to maintain a long and positive partnership with our host community partners and neighbours while generating clean energy. Across Canada, we used this approach to successfully develop 15 wind and solar projects, investing in equity partnerships with municipalities and Aboriginal communities.

Our goal is to develop, build, and operate the Barlow Solar Energy Centre in

order to meet this high standard of success. The development team looks forward to meeting with you and sharing more about the project and its benefits to the Barlow community. If you cannot attend the meeting, or if you have a question at any time, please contact us at any time at:

**844-55-EDF EN** or **BarlowSolar@edf-en.ca**.

Sincerely,



Jon Kieran, Director, Development  
EDF EN Canada Development Inc.

## PUBLIC COMMUNITY MEETINGS INFORMATION

Barlow Energy Centre Limited Partnership is proposing to submit a proposal to the Independent Electricity System Operator (IESO) to design, build, and operate the Barlow Solar Energy Centre for the generation of electricity under the IESO's Large Renewable Procurement (LRP).

The LRP is a competitive process for procuring large renewable energy projects generally larger than 500 kilowatts. At the conclusion of the LRP, the IESO may award contracts for successful projects up to the specified procurement targets for each renewable fuel: 300 megawatts (MW) for wind, 140 MW for solar, 75 MW for waterpower, and 50 MW for bioenergy.

This notice is being distributed to notify members of the public of a public community meeting that has been scheduled to discuss the LRP proposal. Information regarding EDF EN Canada Development Inc., the Barlow Solar Energy Centre, and the meeting details are described below.

This public community meeting is being held as part of the early community engagement requirements of the LRP. The public community meeting will present details about the Barlow Solar Energy Centre and its proposed connection line. Representatives of EDF EN Canada Development Inc. will be available to discuss the Project and the overall LRP process. Should the Barlow Solar Energy Centre be awarded a contract, the Project would need to obtain all required permits and approvals and conduct any further required community engagement activities.

Further details regarding the LRP process are available at [www.ieso.ca/lrp](http://www.ieso.ca/lrp)

### PROPOSER:

Barlow Energy Centre Limited Partnership (LP)

### QUALIFIED APPLICANT FROM THE LRP RFQ STAGE:

EDF EN Canada Development Inc.

### NAME OF THE PROPOSED PROJECT:

Barlow Solar Energy Centre

### RENEWABLE SOURCE:

Non-Rooftop Solar

### PROPOSED CAPACITY (MW):

12 MWac

### PROPOSED CONNECTION POINT:

Township of South Stormont - NW corner of Power Dam Dr. and Cornwall Centre Rd.

### PROPOSED LOCATION OF THE PROJECT AND CONNECTION LINE:

Township of South Stormont

**WEDNESDAY, AUGUST 19, 2015**

5:00 pm - 8:00 pm

South Stormont Community Hall  
2 Mille Roches Road  
Long Sault, Ontario

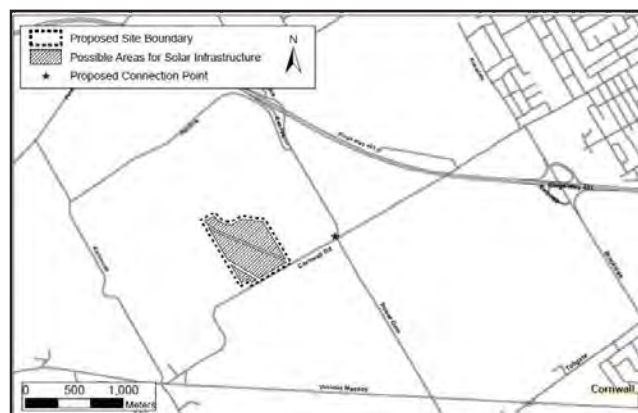

David Thornton  
EDF EN Canada Inc., Stakeholder Relations  
53 Jarvis Street, Suite 300  
Toronto, ON, M5C 2H2  
1-844-55-EDF-EN / 1-844-553-3336

BarlowSolar@edf-en.ca

[www.BarlowSolar.ca](http://www.BarlowSolar.ca)  
[www.edf-en.ca](http://www.edf-en.ca)



EDF EN Canada  
53 Jarvis Street, Suite 300  
Toronto, ON, M5C 2H2



NOTICE OF  
PUBLIC COMMUNITY MEETING  
**WEDNESDAY, AUGUST 19, 2015**  
5:00 - 8:00 PM

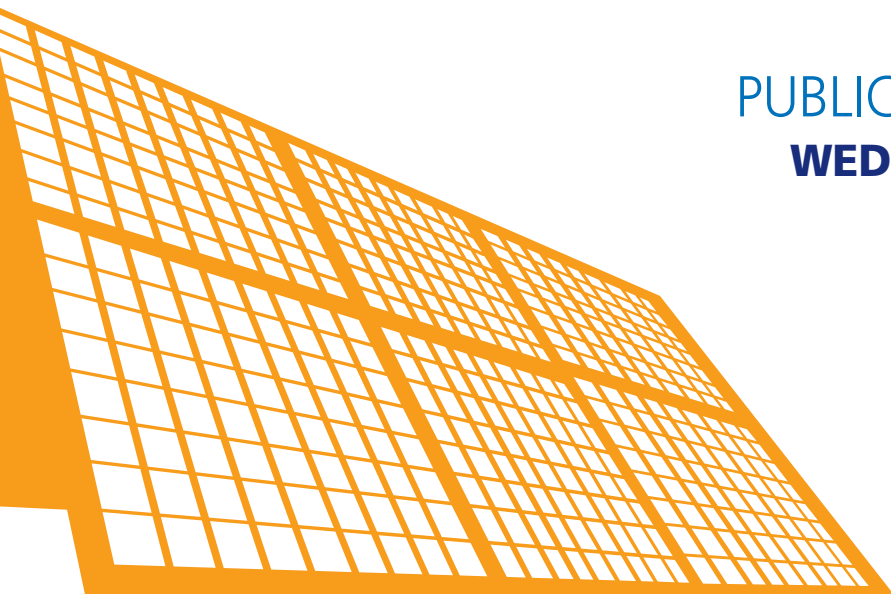

**I would like to personally invite you to attend a Public Meeting for the proposed Barlow Solar Energy Centre.**

In advance of the meeting I wanted to share with you some key project details:

- **EDF EN Canada Development Inc. plans to submit the proposed Barlow Solar Energy Centre into the competitive Large Renewable Procurement (LRP I RFP) process on September 1, 2015;**
- **The proposed Barlow Solar Energy Centre is in the early stages of planning, therefore all project design and layout information is preliminary;**
- **EDF EN Canada Development Inc. will host more public meetings as the project planning continues;**
- **There is no contract yet with the IESO or Ontario government.**

EDF EN Canada Development Inc. operates differently than other renewable energy companies, because we not only develop and build renewable projects, but through our operations and maintenance affiliate—EDF Renewable Services, we intend to operate the facility throughout its life.

Our long-term approach means we judge success by our ability to maintain a long and positive partnership with our host community partners and neighbours while generating clean energy. Across Canada, we used this approach to successfully develop 15 wind and solar projects, investing in equity partnerships with municipalities and Aboriginal communities.

Our goal is to develop, build, and operate the Barlow Solar Energy Centre in order to meet this high standard of success. The development team looks forward to meeting with you and sharing more about the project and its benefits to the Barlow community.

The **first public meeting is in the Township of South Stormont**, and is scheduled for 5:00-8:00 pm on August 19 at the South Stormont Community Hall, 2 Mille Roches Road, in Long Sault, Ontario.

The **second public meeting is in the City of Cornwall**, and is scheduled for 5:00-8:00 pm on August 27 in the Seaway Room, Best Western Plus Parkway Inn, 1515 Vincent Massey Dr., in Cornwall, Ontario.

You are invited to either, or both, of the meetings. If you cannot attend the meeting, or if you have a question at any time, please contact us at any time at: **844-55-EDF EN or BarlowSolar@edf-en.ca.**

Sincerely,

Jon Kieran, Director, Development  
EDF EN Canada Development Inc.

## PUBLIC COMMUNITY MEETINGS INFORMATION

Barlow Energy Centre Limited Partnership is proposing to submit a proposal to the Independent Electricity System Operator (IESO) to design, build, and operate the Barlow Solar Energy Centre for the generation of electricity under the IESO's Large Renewable Procurement (LRP).

The LRP is a competitive process for procuring large renewable energy projects generally larger than 500 kilowatts. At the conclusion of the LRP, the IESO may award contracts for successful projects up to the specified procurement targets for each renewable fuel: 300 megawatts (MW) for wind, 140 MW for solar, 75 MW for waterpower, and 50 MW for bioenergy.

This notice is being distributed to notify members of the public of a public community meeting that has been scheduled to discuss the LRP proposal. Information regarding EDF EN Canada Development Inc., the Barlow Solar Energy Centre, and the meeting details are described below.

This public community meeting is being held as part of the early community engagement requirements of the LRP. The public community meeting will present details about the Barlow Solar Energy Centre and its proposed connection line. Representatives of EDF EN Canada Development Inc. will be available to discuss the Project and the overall LRP process. Should the Barlow Solar Energy Centre be awarded a contract, the Project would need to obtain all required permits and approvals and conduct any further required community engagement activities.

Further details regarding the LRP process are available at [www.ieso.ca/lrp](http://www.ieso.ca/lrp)

### PROPOSER:

Barlow Energy Centre Limited Partnership (LP)

### QUALIFIED APPLICANT FROM THE LRP RFQ STAGE:

EDF EN Canada Development Inc.

### NAME OF THE PROPOSED PROJECT:

Barlow Solar Energy Centre

### RENEWABLE SOURCE:

Non-Rooftop Solar

### PROPOSED CAPACITY (MW):

12 MWac

### PROPOSED CONNECTION POINT:

Township of South Stormont - NW corner of Power Dam Dr. and Cornwall Centre Rd.

### PROPOSED LOCATION OF THE PROJECT AND CONNECTION LINE:

City of Cornwall

**THURSDAY, AUGUST 27, 2015**

5:00 pm - 8:00 pm

The Seaway Room  
Best Western Plus Parkway Inn  
1515 Vincent Massey Drive  
Cornwall, Ontario

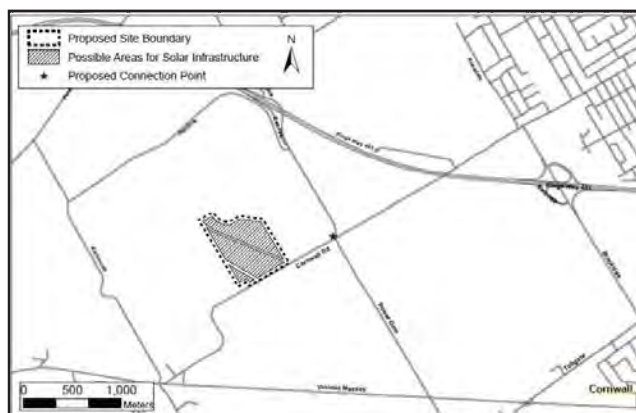

David Thornton  
EDF EN Canada Inc., Stakeholder Relations  
53 Jarvis Street, Suite 300  
Toronto, ON, M5C 2H2  
1-844-55-EDF-EN / 1-844-553-3336

BarlowSolar@edf-en.ca

[www.BarlowSolar.ca](http://www.BarlowSolar.ca)  
[www.edf-en.ca](http://www.edf-en.ca)



NOTICE OF  
PUBLIC COMMUNITY MEETING  
**THURSDAY, AUGUST 27, 2015**  
**5:00 - 8:00 PM**

Note: There are two public meetings  
concerning the solar project.  
Details inside.

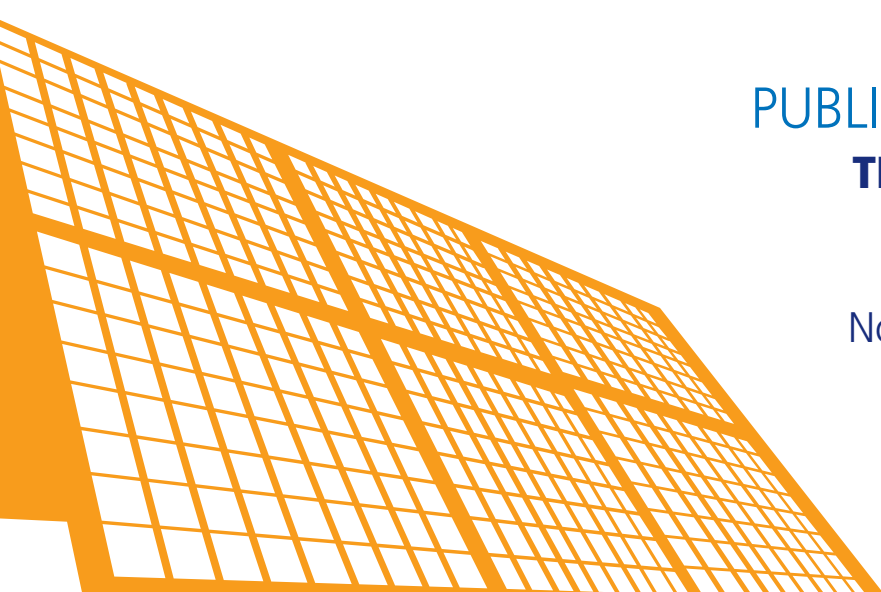



**Barlow Solar Energy Centre**  
**COMMUNITY ENGAGEMENT PLAN** | **Large Renewable Procurement (LRP) I**

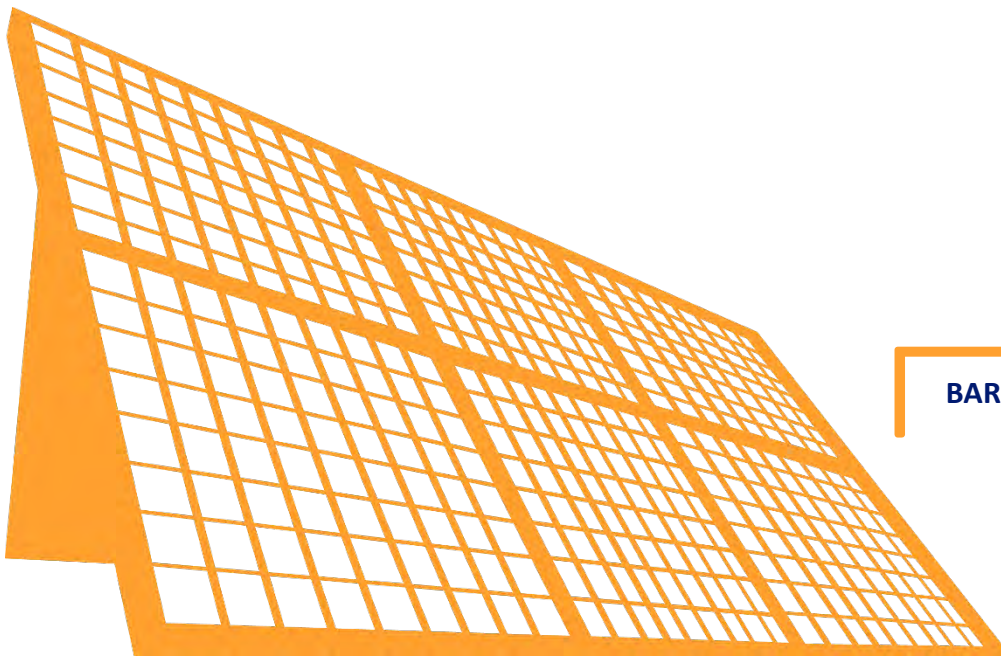

**BARLOW SOLAR ENERGY CENTRE**  
844.553-3336  
BarlowSolar@edf-en.ca  
[www.BarlowSolar.ca](http://www.BarlowSolar.ca)

## Table of Contents

<b>1. Introduction</b>	<b>3</b>
<b>2. Key Project Information</b>	<b>4</b>
<b>3. Company Background</b>	<b>6</b>
<b>4. LRP Background and Timeline</b>	<b>8</b>
i. Request for Qualification (RFQ) Stage	9
ii. Request for Proposal (RFP) Stage	10
iii. Post Contract Award Stage	10
<b>5. Purpose of the Community Engagement Plan</b>	<b>11</b>
<b>6. Stakeholders list</b>	<b>13</b>
i. Land owners and users	13
ii. Aboriginal Stakeholders	13
iii. Municipal & Government Stakeholders	13
iv. Government Agencies	14
v. Special Interest Groups	14
<b>7. Community Engagement Process</b>	<b>14</b>
<b>8. Project and Community Engagement Plan phasing</b>	<b>16</b>
i. Phase 1: Pre-Contract	17
ii. Phase 2: Development and Phase 3: Construction	18
iii. Phase 4: Operation	20
iv. Phase 5: Decommissioning	20
<b>9. Aboriginal Consultation and Engagement</b>	<b>21</b>
<b>10. FAQs</b>	<b>21</b>

## Table of Figures

<b>Figure 1:</b>	<b>Barlow Solar Energy Centre Location map</b>	<b>5</b>
<b>Figure 2:</b>	<b>EDF EN Canada Inc.'s portfolio</b>	<b>7</b>
<b>Figure 3:</b>	<b>LRP annual procurement goal schedule (in MW)</b>	<b>9</b>
<b>Figure 4:</b>	<b>LRP I RFP / Solar project schedule</b>	<b>11</b>
<b>Figure 5:</b>	<b>Barlow Solar Energy Centre and Community Engagement Plan phasing</b>	<b>16</b>



## 1. Introduction

Engaging with the community and incorporating our shared interests in renewable energy projects is extremely important to EDF EN Canada Development Inc.

EDF EN Canada Development Inc. has developed this Community Engagement Plan for the Barlow Solar Energy Centre (the "Project"), a Non-Rooftop Solar power project located in the Township of South Stormont and City of Cornwall. On September 1<sup>st</sup>, 2015, we will apply to the Independent Electricity System Operator ("IESO") under the Large Renewable Procurement I Request for Proposal (the "LRP I RFP") to obtain a power purchase contract for this Project.

The goals of this Community Engagement Plan are to:

- Share Project information;
- Provide an overview of the LRP I RFP process;
- Outline the level of engagement performed thus far;
- Document our plans for future engagement.

This Community Engagement Plan provides an overview of our goals and objectives. To ensure the proposed plan remains relevant and reflective of community interests, we anticipate ongoing collaboration and discussion between EDF EN Canada Development Inc. and all interested stakeholders to amend and adjust the plan.

We are sensitive to ensuring the Barlow Solar Energy Centre is properly integrated into your community. Should the Project be awarded a contract, it will be operational for a period of at least 20 years. Effective integration of your views and insights throughout our development process, construction, operation and decommissioning phases is critical to a successful development.

## 2. Key Project Information

The Barlow Solar Energy Centre (the “Project”) proposed by Barlow Energy Centre Limited Partnership (“LP”), an EDF EN Canada Development Inc. special purpose entity, is proposing to develop, construct and operate the Barlow Solar Energy Centre (the “Project”).

The proposed Project is situated on up to two parcels of land with a total area of about 100 acres. The land is privately owned with a maximum nameplate capacity of 12 megawatts alternative current (MWac), located adjacent to and north of the municipal boundary of the Township of South Stormont and the City of Cornwall, near the corner of Cornwall Centre Road and Power Dam Drive, approximately 10 km west of the city centre of Cornwall, Ontario.

The proposed Connection Point to the public grid is anticipated to be located on the existing distribution circuit on the northwest corner of Cornwall Centre Road and Power Dam Drive, about 600 metres east of the Site.

On September 1, 2015, we will apply to the Independent Electricity System Operator (IESO) under the Large Renewable Procurement I Request for Proposal (the “LRP I RFP”) to obtain a power purchase contract for this Project.

Within this competitive process, the Project will be assessed and evaluated against other proposals for new renewable energy generation. Proposals offering the most competitive electricity prices, with evidence of community and Aboriginal support may be awarded a 20 year agreement with the IESO for sale of electricity through a Power Purchase Agreement (“PPA”). “

Large Renewable Procurement I (“LRP I”) rules and requirements ensure a fair and equitable procurement process, awarding PPAs to only the best projects.

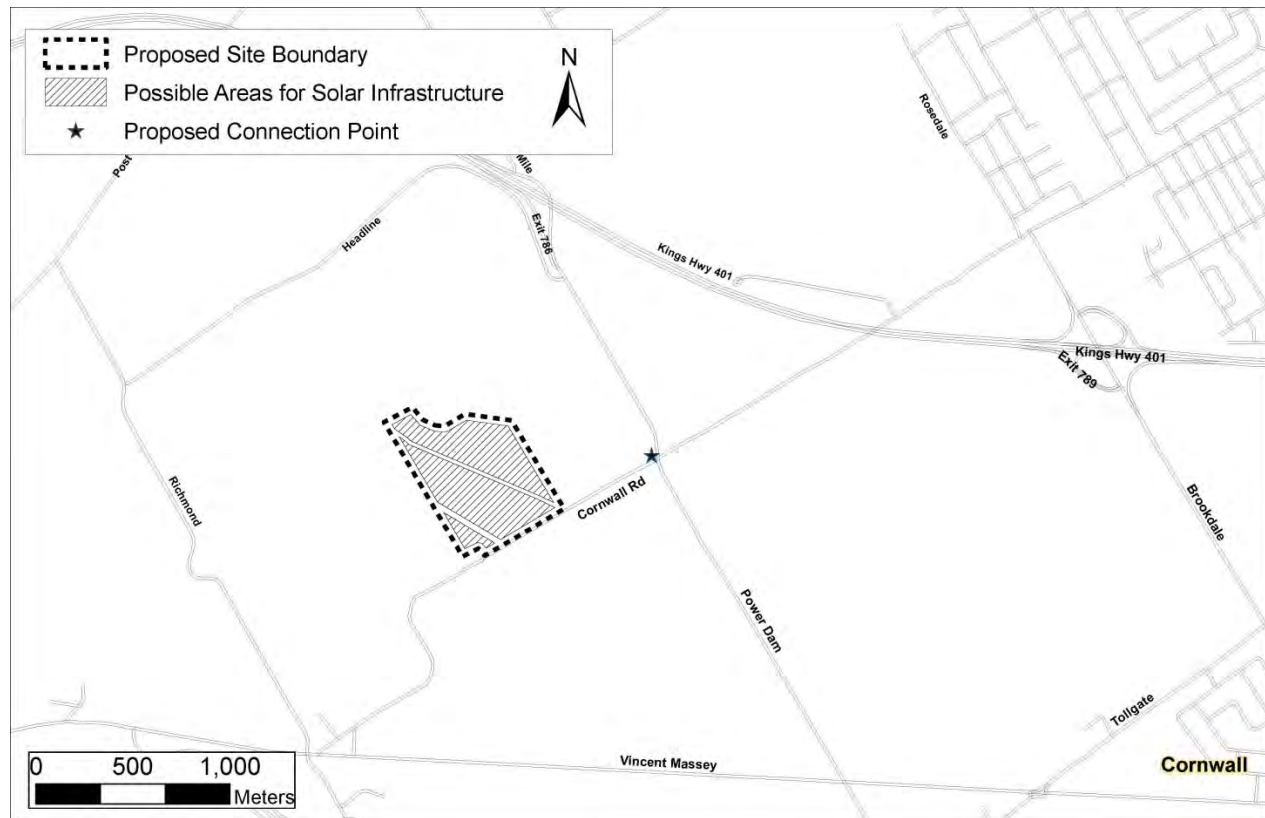

Figure 1: Barlow Solar Energy Centre Location map

The above map illustrates the general arrangement of the Project, including the proposed Site, Possible Areas for Solar Infrastructure and the proposed Connection Point.

As the Project is in the early stages of development, the final locations of Project infrastructure such as solar panel structures, access roads, inverters, transformers, substation and collector system have not yet been finalized.

The final layout will be determined after gathering feedback from field studies, the local communities, stakeholders and Aboriginal communities. Environmental and technical studies help us better understand the potential impacts on the community, natural heritage, cultural heritage, archaeology and other key local considerations. While all development has some impact on the environment, our goal is to ensure we have addressed local interests and minimized potential impacts as a result of our proposed Project.

### 3. Company Background

Barlow Solar Energy Centre LP is a special purpose entity property of EDF EN Canada Development Inc., a wholly-owned subsidiary of EDF EN Canada Inc.

EDF EN Canada Inc. develops, builds, owns and, through its dedicated parent company EDF Renewable Services, operates and maintains renewable energy facilities that harness the earth's renewable resources including the wind and the sun to help mitigate climate change and drive the green energy economy through the creation of new jobs within the immediate project communities and surrounding areas.

Established in 2006, EDF EN Canada Inc. has become a Canadian market leader with over 1,500 MW of wind and solar energy in varying stages of development, active construction, and operation in Quebec, Ontario and Alberta, employing more than 100 full time jobs.

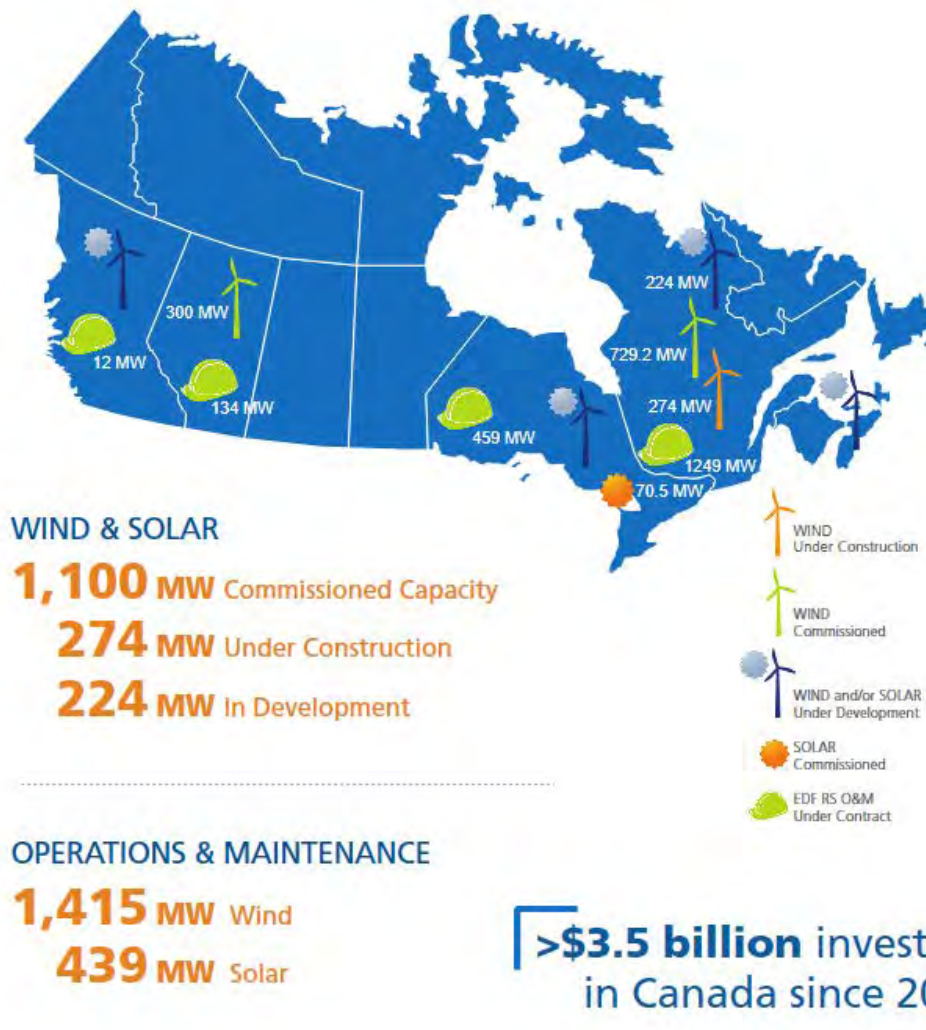

Figure 2: EDF EN Canada Inc.'s portfolio

Very few renewable energy companies operating in Canada today have our depth of experience and expertise in all areas of renewable project development from: site selection, resource assessment, community engagement, procurement, project financing, permitting, and project planning. Once a contract has been secured, EDF EN Canada Inc. and its affiliates also manage the construction, long-term management, operations and maintenance (O&M), and decommissioning or repowering of its renewable energy facilities.

We pride ourselves on our commitment to building long lasting relationships and trusted partnerships with Municipalities, project neighbors, government utilities, regulatory agencies and Aboriginal communities.

To ensure we meet our shared goals, we follow these Core Values:

### Safety

Creating a workplace focused on the health and well-being of the employees, the environment, our customers, and the communities where we do business

### Good Sense

Exercising sound business judgement in all our decisions and actions in order to accomplish our mission

### Accountability

Taking personal ownership and pride in our actions and always putting forward the best effort

### Transparency

Openly communicating, actively listening, challenging ideas and processes, and setting reasonable expectations to achieve the best possible outcome

### Teamwork

Working together to foster creativity and leveraging individual strengths to reach common goals and objectives

### Respect

Being honest and forthright in everything we do; while understanding and valuing the contributions and priorities of others

### Passion

Dedication to our mission, clients, our company, the environment and each other

## 4. LRP Background and Timeline

The government of Ontario released its Long Term Energy Plan in December 2013 committing the Independent Electricity System Operator (IESO) to procure additional renewable energy projects. The government set an ambitious target of 20,000 MW of renewable energy generation in Ontario by 2025.

In March 2014 the former OPA (now the IESO) announced a move away from the old Feed-In Tariff (FIT) program to make room for a new more competitive process which favours

local engagement and best value for the rate payers. This new program is the current Large Renewable Procurement or “LRP” process.

Below is a chart outlining the proposed procurement “schedule” under the first, second and third phases of the LRP:

RENEWABLE TYPE	2015 LRP I	2016 LRP II	2017 LRP III
WIND	300	300	<i>Any remaining renewable MW un-procured from FIT, LRP I and/or LRP II will be procured in LRP III</i>
SOLAR	140	140	
WATERPOWER	75	45	
BIOENERGY: BIOMASS / BIOGAS	50	50	

Figure 3: LRP annual procurement goal schedule (in MW)

The LRP process requires renewable energy project developers, such as EDF EN Canada Development Inc., to move through two pre-contract stages before a power purchase contract is awarded: a Request for Qualification (RFQ) stage, and a Request for Proposals (RFP) stage. Details on both stages are outlined below.

### **i. Request for Qualification (RFQ) Stage**

The LRP I RFQ was issued by the IESO in July 2014. The LRP I RFQ rules can be found here: <http://www.powerauthority.on.ca/sites/default/files/planning/LRP-I-RFQ.pdf>.

The LRP I RFQ required applicants to demonstrate their ability to submit large renewable projects in the upcoming Request for Proposal (RFP). The applicant’s suitability assessment was evaluated on experience and financial capability.

In November 2014, the IESO confirmed EDF EN Canada Development Inc. was a Qualified Applicant and could therefore submit proposals in the following renewable energy

categories of the LRP I RFP: On-Shore Wind, Non-Rooftop Solar, Rooftop Solar, Renewable Biomass and Biogas.

## ii. Request for Proposal (RFP) Stage

In March 2015, the IESO published the final rules and contract for the LRP I RFP. EDF EN Canada Development Inc. is required to register its proposed projects by August 7, 2015 and submit them to the IESO LRP I RFP no later than September 1, 2015. The links to both documents are below:

<http://www.ieso.ca/Documents/generation-procurement/lrp/lrp-1-final/LRP-I-RFP.pdf>

<http://www.ieso.ca/Documents/generation-procurement/lrp/lrp-1-final/LRP-I-Contract.pdf>

The LRP I RFP requirements were developed by the IESO following a thorough stakeholder engagement process. The main goal of the LRP I RFP is to create a competitive process aimed at achieving the lowest cost electricity for Ontario rate payers. In addition to focusing on price, the IESO favours projects that demonstrate support from the host Municipality/ies, project neighbours and Aboriginal communities.

A number of “Rated Criteria” points are awarded to projects that:

- Secured a Municipal Council support resolution;
- Completed a Municipal agreement;
  - Community benefit agreement or other agreement regarding road and other infrastructures use, etc.;
- Obtained support from at least 75% of assessed private property owners abutting the Project Site and on which the proposed Connection Line is located;
- Signed a partnership agreement with an Aboriginal community.

The IESO will then review and assess proposals submitted on or before September 1, 2015. Successful applicants will likely be announced before the end of 2015.

## iii. Post Contract Award Stage

Should the Barlow Solar Energy Centre be awarded a power purchase contract, the Project would then follow a very rigorous permitting process known as the Renewable Energy Approval (REA) process.



The REA process outlines standards for the protection of the environment, cultural heritage and continued engagement with members of the public, local Municipalities and Aboriginal communities.

Pending successful permitting, the Barlow Solar Energy Centre is anticipated to begin construction in late 2017 or 2018.

The illustration below outlines the general LRP I RFP schedule and associated Project timeline:

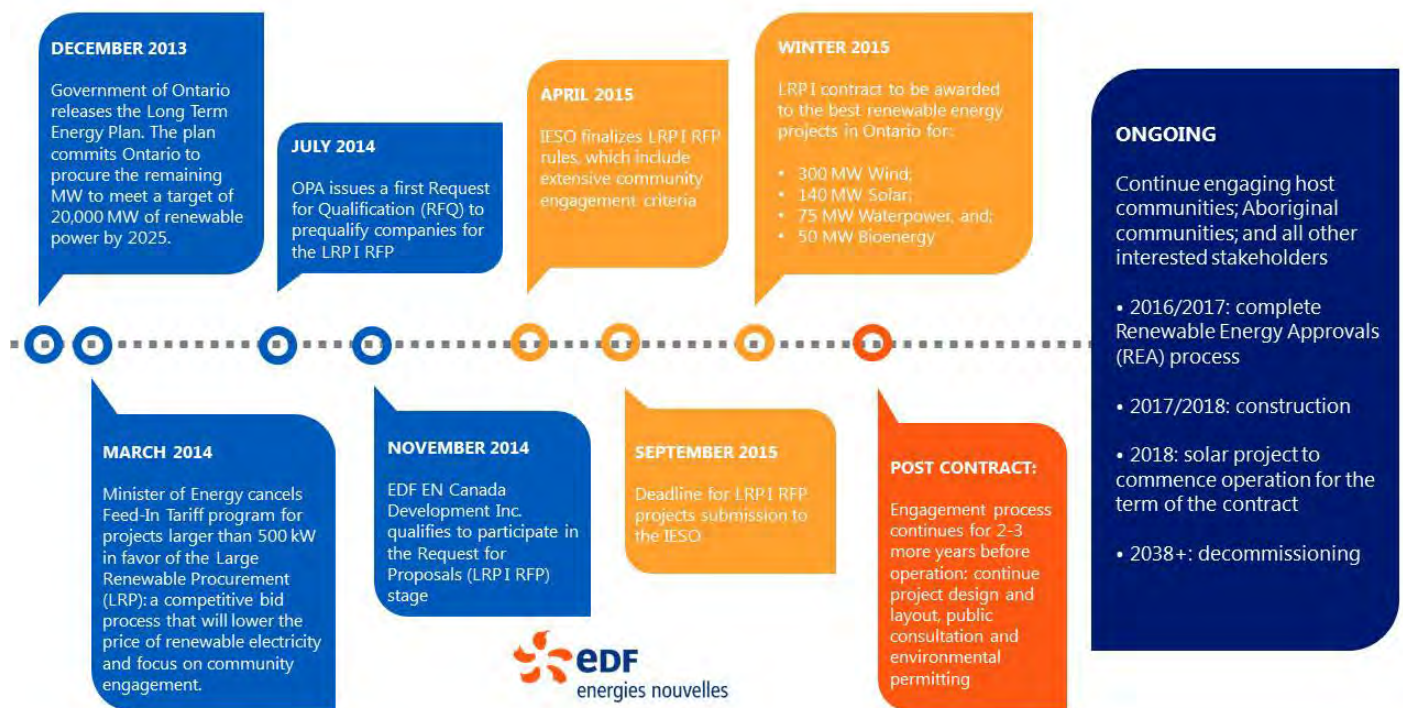

Figure 4: LRP I RFP / Solar project schedule

## 5. Purpose of the Community Engagement Plan

The Barlow Solar Energy Centre Community Engagement Plan outlines an engagement process to create and maintain an open and productive trusted dialogue between EDF EN Canada Development Inc., and any interested stakeholders or Aboriginal communities.

The Community Engagement Plan will:

- Identify and maintain a list of interested stakeholders and Aboriginal communities that EDF EN Canada Development Inc. will proactively engage and consult with on an on-going basis;
- Develop user-friendly, and publically accessible Project information to allow opportunities for interested stakeholders and Aboriginal communities to understand the proposed Project;
- Provide opportunities for all interested stakeholders and Aboriginal communities to be involved throughout the Project life-cycle, including Project pre-submission period, and if awarded a contract, the REA process, including the planning and development of Project design considerations, construction, operation and decommissioning;
- Contribute to the collection and sharing of information related to the potential environmental, economic, social, and heritage of the proposed Project;
- Collect and respond to public input and comments;
- Identify and understand interests that stakeholders and Aboriginal communities identify in regards to the Project. These questions may be related to social, environmental, economic, health and heritage interests. These topics will inform the identification of “valued components” to be considered in Project design and addressed in the Renewable Energy Approval (REA);
- Proactively promote Project engagement through direct mail, newspaper advertisements, open houses and an evergreen website. Our goal is to ensure all interested parties have access to Project information.

## 6. Stakeholders list

Identifying interested stakeholders and Aboriginal communities is an essential part of Project planning. We intend to make every effort to keep the following list up-to-date throughout the whole lifecycle of the Project.

As the Community Engagement Plan is a public document, we must respect the privacy of the individuals in accordance with the *Personal Information Protection and Electronic Documents Act, 2000*; therefore the stakeholders list will not contain any information regarding a private individual or individual landowner.

The LRP I RFP rules outline consultation requirements which must be met prior to proposal submission, including specific stakeholders who must be contacted. In addition to those stakeholders identified in the LRP I RFP rules, EDF EN Canada Development Inc. has proactively engaged with additional members of the community we believe, based on our experience, would be interested in Project details.

EDF EN Canada Development Inc. commits to engaging the following stakeholders throughout the Project lifecycle, from early development to decommissioning.

### i. Land owners and users

- Owners or tenants of the Properties constituting the Project Site;
- Assessed owners of property;
  - Within 120 meters of the Properties constituting the Site, and;
  - Within 120 meters from the proposed Connection Line.

### ii. Aboriginal Stakeholders

- Aboriginal communities who may have an interest in the Project (see Appendix I – List of Aboriginal Communities)

### iii. Municipal & Government Stakeholders

- Mayor and council of the Township of South Stormont and City of Cornwall, where the Project and proposed Connection Line will be located;

- Clerk and other staff of the Township of South Stormont and City of Cornwall, where the Project and proposed Connection Line will be located.

#### **iv. Government Agencies**

- The General Manager / Secretary Treasurer of Raisin Region Conservation Authority;
- The Director, Environmental Approvals Access and Service Integration Branch, Ministry of the Environment and Climate Change;
- Ministry of Tourism, Culture and Sport (MTCS);
- The Director, Engineering and Development Branch, Environment Canada.

#### **v. Special Interest Groups**

- Non-Governmental Organizations (NGOs);
- Industry Associations;
- Local Businesses and Business Industry Associations (BIAs);
- Secretary Treasurer and Property Administrator, Trans-Northern Pipeline Inc.

The list of currently identified stakeholders for the Barlow Solar Energy Centre, not including Aboriginal communities, listed separately, and private persons, not listed here, can be found as Appendix II.

## **7. Community Engagement Process**

Our community engagement process is meant to:

- Inform stakeholders and Aboriginal communities of the Project by communicating potential environmental, social, economic, and land use changes;
- Collect, consider and respond to feedback from stakeholders and Aboriginal communities.

EDF EN Canada Development Inc. will engage with the community through 2 different methods and related actions:

- Information; and
- Consultation

## Information

A major goal of our Community Engagement Plan is to inform stakeholders and Aboriginal communities about the Project and its progress. Information sharing will include, but not be limited to:

- Project website;
- Notice of Public Community Meeting;
- Public Community Meetings;
- Advertising in Community and Aboriginal newspapers;
- Mail to Landowners within 120 m of the Site and the proposed Connection Line;
- Public Community Meeting Summary.

## Consultation

In addition to informing the community, we want to create opportunities for stakeholders (including local community groups, adjacent landowners, other tenure holders and local businesses) and Aboriginal communities to provide feedback that will be considered for integration into our Project plans.

EDF EN Canada Development Inc. invites stakeholders and Aboriginal communities who have an interest in the Project to provide their input.

Consultation will be supported, but not limited, by the following tools:

- Personal exchanges and one-on-one meetings;
- Public open houses;
- Public meetings with the Municipal Council;
- Project-specific mailing lists; and
- Feedback via the Project website.

The above tools can be supplemented by other tools as determined during the consultation process.

## 8. Project and Community Engagement Plan phasing

A typical project timeline is divided into 5 phases. The community engagement structure is progressive and consists of the following phases:

- I. Phase 1: Pre-Contract (up to contract award date, expected December 2015)
- II. Phase 2: Development (2 years)
- III. Phase 3: Construction (6 months-1 year)
- IV. Phase 4: Operation (+20 years)
- V. Phase 5: Decommissioning (6 months-1 year)

Each of these phases is directed towards slightly different objectives and goals. Engagement at this time (Phase 1) is focused on sharing preliminary Project information, getting to know the community, and collecting feedback from neighbors, project stakeholders and interested Aboriginal communities, as per our experience and good practices, as well as the LRP I RFP requirements.



Figure 5: Barlow Solar Energy Centre and Community Engagement Plan phasing

## **i. Phase 1: Pre-Contract**

During Phase 1, the community engagement process is meant to:

- Inform stakeholders and Aboriginal communities about the Project;
- Collect comments and interest;
- Respond to any questions and attempt to address as many concerns regarding the Project as possible.

The two-way dialogue between the Project development team, stakeholders and Aboriginal communities will be an exchange of information to create the Project design parameters necessary to integrate the needs of all parties.

The Pre-Contract phase is currently ongoing and will end when the Project is awarded an LRP I contract (December 2015). The following engagement tasks, as a minimum, will be part of the Community Engagement Plan for the Pre-Contract phase. The vast majority of these items will occur before the submission date, September 1, 2015.

- Inform the Township of South Stormont and City of Cornwall by engaging with staff and organizing a delegation at one or more Municipal Council meetings;
- Create and manage a Project website, keeping content current with relevant Project information. The website will have a unique email address to collect feedback. Those who supply feedback through the website will be added to our email distribution list. The website will host all public documents from Public Community Meetings in addition to helpful links for studies and research on solar technology;
- Share a copy of the Community Engagement Plan with the Township of South Stormont and City of Cornwall before the Public Community Meeting and post the Community Engagement Plan on the Project website at least fifteen (15) days before the Public Community Meeting;
- Host one (1) Public Community Meeting in the Township of South Stormont and City of Cornwall. The meeting will include information and displays showing the location of the proposed Project and the proposed Connection. Information pertaining to solar energy generation, the Community Engagement Plan and updates on the status and progress of development activities, such as the environmental assessment and anticipated construction schedule will be made available;

- Provide public notice in advance of the Public Community Meeting in two (2) separate publications of a local newspaper;
- Send, via direct mail, public notice of the Public Community Meeting to residents and assessed owners of Properties located within 120 meters of the Project Site and 120 meters of the proposed Connection Line;
- Post a summary of the Public Community Meeting to the Project website, and issue a copy to the clerk of the Township of South Stormont and City of Cornwall;
- Upon request, EDF EN Canada Development Inc. will host meetings with Aboriginal Communities; and
- Where appropriate, respond to questions and concerns raised during our engagement process.

**The South Stormont Public Community Meeting will be held on Wednesday August 19th, from 5pm to 8pm, at the South Stormont Community Hall, 2 Mille Roches Rd, Long Sault, Ontario, K0C 1P0.**

**The City of Cornwall Public Community Meeting will be held on Thursday August 27th, from 5pm to 8pm, at the Seaway Room, Best Western Plus Parkway Inn & Conference Centre, 1515 Vincent Massey Dr., Cornwall, ON K6H 5R6**

If members of the community are not able to attend, we encourage all to visit our website where the Public Community Meeting documents will be posted, or to contact us directly by e-mail or phone.

## **ii. Phase 2: Development and Phase 3: Construction**

Should Barlow Energy Centre Limited Partnership be awarded a power purchase contract by the IESO for the Barlow Solar Energy Centre, EDF EN Canada Development Inc. is committed to continuing its engagement with all interested stakeholders throughout the lifecycle of the Project.

During the Development and Construction phases, engagement will focus on continuing to inform stakeholders and Aboriginal communities of the Project progress, monitoring



and managing stakeholder and Aboriginal community interest and perspectives, as well as ensuring the Project meets all permitting obligations as set out by the Ministry of the Environment and Climate Change (MOECC) in the Renewable Energy Approval (REA) process.

The stages and requirements of the REA are located on the Ministry's website: <http://www.ontario.ca/environment-and-energy/renewable-energy-approvals>.

Phase 2 will begin as soon as a power purchase contract is awarded in late 2015 through the start of construction (expected in late 2017 or 2018). Once construction is underway, Phase 3 of the engagement plan will take effect.

The following engagement tasks are anticipated during Phases 2 and 3:

- At least two (2) additional open house meetings will be held prior to submission of the REA to communicate how the development team incorporated stakeholder feedback in Project design. In addition, the open houses will provide an opportunity for interested stakeholders to review and comment on the results of technical studies and project reports;
- Continue meetings with the Township of South Stormont and City of Cornwall to keep them apprised of the Project's progress. EDF EN Canada Development Inc. also intends to work with the staff and representatives of the Township of South Stormont and City of Cornwall to negotiate road-use agreements and other Project logistics;
- Continue meetings with Aboriginal communities, keeping them apprised of Project progress and gathering their feedback. Should members of the Aboriginal communities have an interest in participating in archaeology or other field studies, we will work to schedule and incorporate their requests where possible;
- Work to establish a Community Liaison Committee (CLC) by convening a special task force to assemble the committee members;
- Develop an Emergency Response and Public Safety Plan with local public safety authorities;
- Develop and engage the community on the Decommissioning Plan;
- Regularly update the Project website as needed with any new and relevant information;

- Record and publish questions and comments from interested stakeholders on our Project website.

### **iii. Phase 4: Operation**

The objectives and goals of this phase will be focused on executing all previously negotiated agreements between EDF EN Canada Development Inc. and Barlow Energy Centre LP, the Province of Ontario, the Township of South Stormont and City of Cornwall, the Project's host landowner and other applicable persons and entities, as well as ensuring the Facility operates efficiently and safely.

The Barlow Solar Energy Centre Facility (the "Facility") Operation Phase is anticipated to last at least 20 years from the time the Project achieves Commercial Operation (i.e. is fully operational), until the Facility decommissions.

The following engagement tasks are anticipated during Phase 4. Additional engagement tasks may be added throughout the consultation process.

- Manage the safe operation of the Facility;
- Support community activities and enterprises;
- Effectively develop, communicate and run a public safety protocol;
- Execute all landowners agreements;
- Execute all Municipal and County agreements as applicable; and
- Execute all Aboriginal agreements, as applicable.

When this Project is no longer efficient to operate, it may be possible to replace aging equipment with new equipment. This type of replacement is called "repowering" a site. Prior to making a decision to repower a facility with new solar panels or electrical equipment, EDF EN Canada Development Inc. would first engage with the Site landowners, local and provincial governments, stakeholders and local Aboriginal communities.

### **iv. Phase 5: Decommissioning**

At this stage of the Facility's lifecycle, EDF EN Canada Development Inc., based on our experience in multiple jurisdictions across North America and our best practices, will implement a Decommissioning Plan compliant with all prescribed municipal and provincial regulations and requirements. Property landowners, tenants, neighbors and the host

Municipality will again be consulted to ensure the community is aware of the proposed Decommissioning Plan.

## 9. Aboriginal Consultation and Engagement

We embrace our duty and obligation to engage with local Aboriginal communities. Working with the Ontario government, we will obtain a listing of communities who exercise their constitutionally protected Aboriginal or Treaty Rights on the lands we wish to develop (see Appendix I – List of Aboriginal Communities).

The listing of Aboriginal Communities outlined in Appendix I is not intended to be a fulsome description of right and title holders. A more robust list will be generated by the Government of Ontario should the Project be awarded a power purchase contract and move into the REA process. We encourage any Aboriginal Communities not currently listed in Appendix I, who wish to make their interests known, to please contact us directly through the Contact Information provided on our website and in the present document.

A Notice of Public Community Meeting will be distributed to identified Aboriginal Communities at least fifteen (15) days in advance to the Public Community Meeting held during Phase 1 – Pre Contract Phase. Information about when and where the meetings will take place, as well as where the Aboriginal community can view project documents prior to the meeting will be included in this notice.

If available, a Notice of Public Meeting will also be posted in relevant Aboriginal newspapers.

## 10. FAQs

EDF EN Canada Development Inc. is committed to posting and responding to comments to the Project website.

We will track all comments, issues, and responses in a format similar to that of the table below:

Date	Method of Communication	Topic/Issue	Summary of Communication	Response

Table 1: FAQ structure example

We will respond to questions and comments:

- That are identified or submitted during the Public Community Meeting; and
- That are presented through the “contact” section of the Project Website.

These comments enhance our understanding of potential environmental, social, economic, health, or heritage impacts and inform Project development, design, construction, or operation.

## *Appendix I: List of Aboriginal Communities*

The following is a list of Aboriginal Communities that may be affected by or otherwise interested in the Project:

<b>Name</b>	<b>Contact</b>
Mohawks of Akwesasne	Grand Chief
Mohawks of the Bay of Quinte	Chief
Metis Nation of Ontario	Manager of Lands, Resources and Consultations, Métis Nation of Ontario
Ottawa Regional Métis	President
Métis Nation of Ontario - High Land Waters Métis Council	President

## *Appendix II: List of Project stakeholders*

The following is the list of identified stakeholders that may be affected by or otherwise interested in the Project, to the exception of Aboriginal Communities, listed as Appendix I, and of private individuals, not listed here for security and regulatory purposes:

<b>Name</b>	<b>Contact</b>
Township of South Stormont and City of Cornwall	Mayor, Council, Clerk/CAO, Planner
Raisin Region Conservation Authority	General Manager
Ministry of the Environment and Climate Change, Public Information Centre	Director, Environmental Approvals Access and Service Integration Branch
Trans-Northern Pipeline Inc.	Secretary Treasurer, Property Administrator



First Public Community Meetings  
August 19<sup>th</sup> & August 27<sup>th</sup>, 2015

MEETING SUMMARY  
REPORT

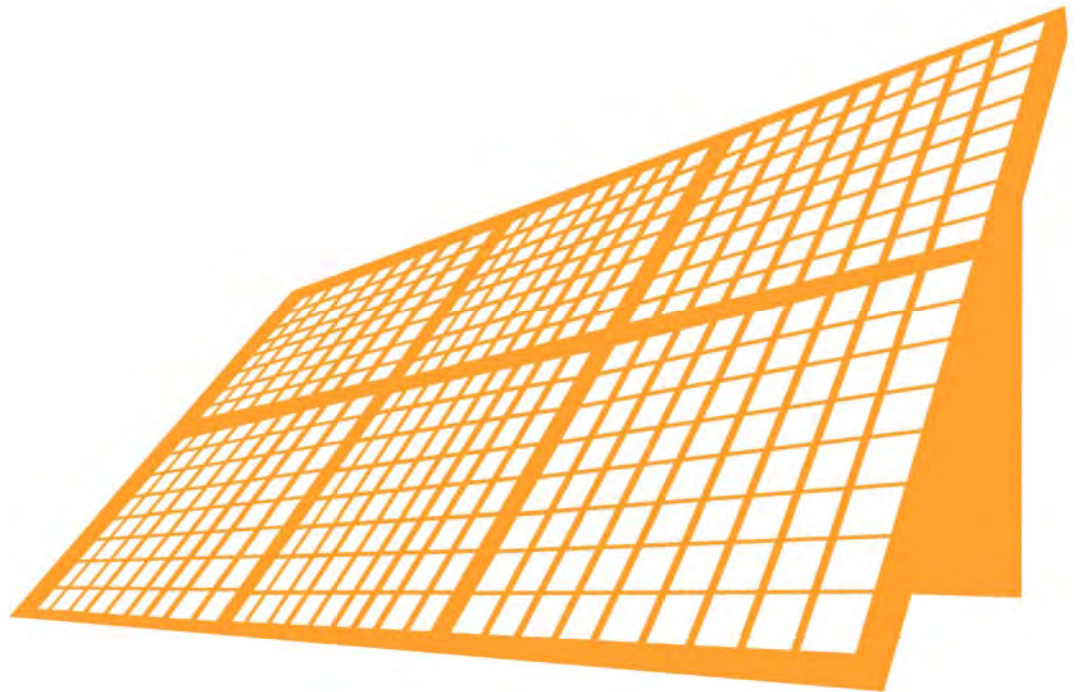

BARLOW SOLAR ENERGY CENTRE

844-55-EDF-EN / 844-553-3336

[BarlowSolar@edf-en.ca](mailto:BarlowSolar@edf-en.ca)

[www.BarlowSolar.ca](http://www.BarlowSolar.ca)



## MEETING SUMMARY REPORT

### 1 Project Summary

Barlow Energy Centre Limited Partnership (the "Registered Proponent") is proposing the Barlow Solar Energy Centre (the "Project") in the Township of North Stormont and the City of Cornwall. Barlow Energy Centre Limited Partnership held two (2) Public Community Meetings within the Project area on August 19, 2015, at the South Stormont Community Hall in South Stormont, Ontario, and on August 27 2015, at the Best Western Parkway Inn in Cornwall, Ontario.

The Barlow Solar Energy Centre first Public Community Meetings (the "Meetings") were held in compliance with the community engagement requirements outlined in the Large Renewable Procurement first Request for Proposal (the "LRP I RFP") being administered by the Independent Electricity System Operator ("IESO") of Ontario.

The Meetings provided an open and interactive venue to exchange information about the proposed Barlow Solar Energy Centre. Information about solar energy and the Project were discussed, ideas were proposed, and feedback was gathered from interested stakeholders, including members of the general public.

This report provides a summary of the Meetings, including the parties notified, meeting information, the feedback received from attendees of the meeting, and our next actions to address the community.

#### 1.1 General Project Description

Barlow Energy Centre Limited Partnership (the "Registered Proponent") is proposing to submit a proposal to the IESO to develop, construct and operate the Barlow Solar Energy Centre on roughly 97 acres of privately-owned land, with a maximum nameplate capacity of 12 megawatt (MW), located in the Township of South Stormont – North-



West corner of Power Dam Drive and Cornwall Centre Road, and, in the City of Cornwall along Cornwall Centre Road.

*Figure 1 – General Project Location*

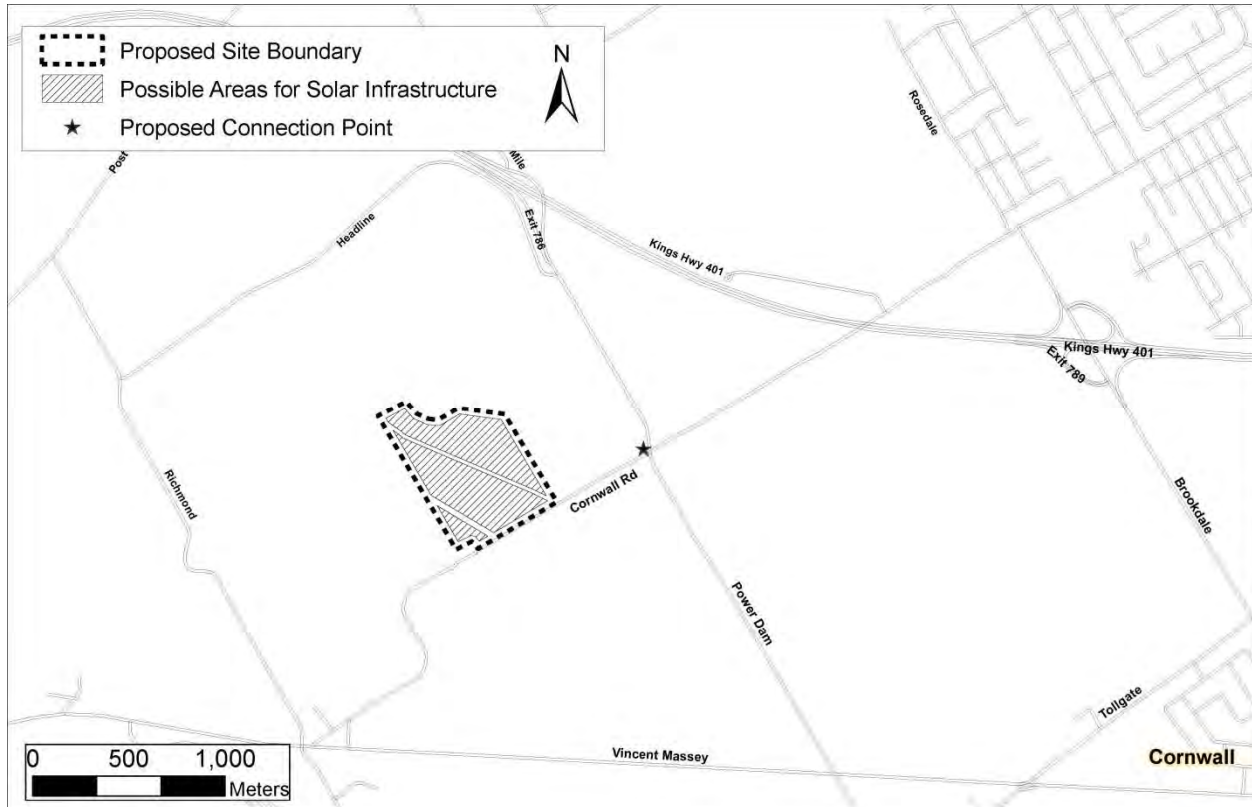

## 1.2 Proponent Information

The Registered Proponent is a special project entity property of EDF EN Canada Development Inc., a wholly-owned subsidiary of EDF EN Canada Inc.

EDF EN Canada Development Inc. (ECDI) is a Qualified Applicant in the IESO LRP I RFP. ECDI and its dedicated parent company EDF Renewable Services develop, build, own and operate renewable energy facilities by harnessing the earth's renewable resources, including the wind and the sun. Renewable energy development mitigates climate

change and drives the green energy economy through the creation of new jobs within the immediate project communities and surrounding areas.

Established in 2006, EDF EN Canada Inc. has become a Canadian market leader with over 1,500 MW of wind and solar energy in varying stages of development, active construction, and operation in Quebec, Ontario and Alberta, employing more than 100 people. More information about EDF EN Canada can be found at <http://www.edf-en.ca>.

Project related information for the Barlow Solar Energy Centre is as follows:

**Qualified Applicant:** EDF EN Canada Development Inc.

**Registered Proponent:** Barlow Energy Centre Limited Partnership

**Mailing Address:** 53 Jarvis Street, Suite 300, Toronto, Ontario, M5C 2H2

**Phone number:** 1-844-55-EDF-EN / 1-844-553-3336

**Email:** BarlowSolar@edf-en.ca

**Project website:** [www.BarlowSolar.ca](http://www.BarlowSolar.ca)

## 2 Public Community Meeting

### 2.1 Overview

The Proponent held a Public Community Meeting for the Project on August 19<sup>th</sup>, 2015, from 5:00 pm until 8:00 pm at the South Stormont Community Hall in South Stormont, Ontario. Seven (7) representatives for the Proponent were at the meeting during the three hour event to present information and to discuss the Project proposal.

The Proponent also held a Public Community Meeting for the Project on August 27<sup>th</sup>, 2015, from 5:00 pm until 8:00 pm in the Seaway Room at the Best Western Parkway Inn in Cornwall, Ontario. Four (4) representatives for the Proponent were at the meeting during the three hour event to present information and to discuss the Project proposal.

The Meetings had the following products:

- Project Display Boards
- Site Considerations Report
- Site Consideration Maps
- Community Engagement Plan
- Sign-In Sheet
- Questionnaire/Comment Form
- Project Profile
- Company Brochure
- EDF EN Company Brochure (English and French)
- EDF EN Take Aways
  - EDF EN Shopping Bag
  - Pens

## **2.2 Public Notice and Public Meeting Advertisement**

Leading up to the event, the Meeting was advertised in the following ways:

- Public Notice to Assessed landowners within 120 m of the Site and the proposed Connection Line
- Public Notice to all required parties as per section 3.2.5.(d).(i).(4) of LRP I RFP
- Public Notice Advertisement in a Local Weekly Newspaper for the August 19<sup>th</sup> Meeting (Cornwall Standard Freeholder: Monday August 10<sup>th</sup> 2015; Monday August 17<sup>th</sup> 2015)
- Public Notice Advertisement in a Local Weekly Newspaper for the August 27<sup>th</sup> Meeting (Cornwall Standard Freeholder: Monday August 17<sup>th</sup> 2015; and Monday August 24<sup>th</sup>, 2015)
- Media Outreach
- Personal invitation to the Meetings to Mayor and Council of the Township of South Stormont and the City of Cornwall
- Personal invitation to the Meetings to Aboriginal communities identified in the Community Engagement Plan as well as other local stakeholders

The public meeting notice was prepared, published, and disseminated in accordance with the LRP I RFP requirements.

### **2.3 Information Presented at the Meeting**

The information presented at the Meeting includes the Site Considerations Information and maps (as required by the IESO in the LRP I RFP), a review document of the Site Considerations Information including sources of background information, the Project's Community Engagement Plan, and a collection of story boards with relevant information about the Project, the IESO's LRP I RFP, solar energy, and the Project development timeline.

Most of the documents presented at the meeting are available for viewing and download on the Project Website at [www.BarlowSolar.ca](http://www.BarlowSolar.ca).

### **2.4 Meeting Attendance**

The August 19<sup>th</sup> Meeting was attended by seven (7) members of the public, and were all residents living in the Township of South Stormont, and area residents living close to the proposed Project.

The August 27<sup>th</sup> Meeting was attended by five (5) members of the public, one of which was a media representative from the Cornwall Standard Freeholder. The other four (4) were neighbours of the private landowner.

In total, the Meetings hosted a total of twelve (12) attendees.

### **2.5 Feedback Received**

Proponent staff engaged all of the attendees at the Meetings and requested that everyone complete a Comment Form.

Out of the twelve (12) attendees, Five (5) of those who attended the Meeting completed and submitted a feedback form.

A summary of the optional (multiple choice) questions is presented in Tables 1 and 2 below.

**Table 1: Summary of Support Question Provided to the Public**

Question	Yes	No	Undecided
Are You in Favour of Solar Energy Development in Ontario	2	2	0

Out of the four (5) attendees who submitted a feedback form, two (2) were in favour of solar energy development in Ontario, with the remaining two (2) being undecided. One (1) did not mark a box.

**Table 2: Summary of Questions Provided to the Public**

Question	Completely Agree	Agree	Disagree	Completely Disagree	No Opinion
Solar energy is a form of clean, non-polluting energy	0	2	0	0	1
Solar energy generates significant local and regional economic benefits	0	1	0	0	2
Solar energy will provide significant community benefits	0	1	1	0	1
Solar Energy is an important part of Ontario's energy mix	0	2	0	0	1

Solar energy blends well with the landscape	0	0	1	0	2
Solar energy has little impact on the environment (Flora and fauna)	0	1	0	0	2
Do You Agree With the Barlow Solar Energy Project Being Proposed by EDF EN Canada Development Inc.?	0	1	0	1	3

Based on the responses illustrated in Table 2, the majority of responders had no opinion on whether they agreed with the proposed project. Half (50%) also had no opinion whether solar has little impact on the environment and whether it blends in well with the landscape. However, half (50%) did think solar is an important part of the energy mix in Ontario, and agreed it is a clean form of electricity generation.

Respondents were also encouraged, through the feedback forms, to provide more general open ended feedback on the following discussion points:

- What Modifications and/or additional Information Would Help Improve the Project Design?
- What are your main concerns and questions with regard to the Barlow Solar Energy Centre?
- Please indicate any additional comment or other information relevant to this project

A summary of the written comments received from the public based on the above questions is provided in Table 3.

**Table 3: Summary of Feedback Received by EDF EN Canada from the Public**

**Comments/Concerns/Questions**

Would Like to see some benefits electrically through Hydro One for the members of the community where solar projects are being proposed

Costs millions of dollars to build

There is nothing the municipality can do as to where these projects are located

(Not pleased with the insufficient level of detail in the map on the advertisement)

These comments and questions will be addressed through specific responses on the Project website. Through the website interested stakeholders are encouraged to submit any further questions or comments they might have about the proposal.

### 3 Conclusion

A Public Community Meeting was held on August 19<sup>th</sup>, 2015, at the South Stormont Community Hall from 5:00 pm to 8:00 pm for the proposed Barlow Solar Energy Centre project. Seven (7) people attended the event.

A Public Community Meeting was held on August 27<sup>th</sup>, 2015, in the Seaway Room at the Best Western Parkway Inn in Cornwall, Ontario from 5:00 pm until 8:00 pm. Five (5) people attended the event.

Over the course of the Meetings, a total of five (5) people provided feedback on the Project, two (2) of which stated that they are in favour of solar energy development in Ontario while the remaining two (2) responders left that specific question blank.

In regards to support for the Barlow Solar Energy Centre, one (1) of responders stated that they Agree with the Barlow Solar Energy Centre project in Ontario while one (1) responder Completely Disagreed. The remaining three (3) responders had no opinion. Moreover, four (4) people out of the five (5) who completed the comment form either supported, or had no objection to the proposed Barlow Solar Energy Centre.

Overall, we are confident to conclude that a majority of attendees support the Barlow Solar Energy Centre Project specifically being proposed by EDF EN Canada.

Their questions and concerns, along with all other feedback received from the public, will be addressed on the website and form part of future consultation mitigation measures, should the Project win a supply contract with the IESO.

Furthermore, the Project design, site studies, and public consultation will take all of this feedback into account as the Project moves into the detailed Renewable Energy Approval ("REA") process, should the Project win a contract from the IESO in the LRP Process. Under the REA process substantial public consultation for 12-18 months will be initiated, further engaging the community.