

ROMNEY WIND ENERGY CENTRE

Renewable Energy Approval Application - Noise Impact Assessment

Romney Energy Centre Limited Partnership

Document No.: 10021083-CAMO-R-01

Issue: G, **Status:** Final

Date: 17 January 2018



IMPORTANT NOTICE AND DISCLAIMER

1. This document is intended for the sole use of the Customer as detailed on the front page of this document to whom the document is addressed and who has entered into a written agreement with the DNV GL entity issuing this document ("DNV GL"). To the extent permitted by law, neither DNV GL nor any group company (the "Group") assumes any responsibility whether in contract, tort including without limitation negligence, or otherwise howsoever, to third parties (being persons other than the Customer), and no company in the Group other than DNV GL shall be liable for any loss or damage whatsoever suffered by virtue of any act, omission or default (whether arising by negligence or otherwise) by DNV GL, the Group or any of its or their servants, subcontractors or agents. This document must be read in its entirety and is subject to any assumptions and qualifications expressed therein as well as in any other relevant communications in connection with it. This document may contain detailed technical data which is intended for use only by persons possessing requisite expertise in its subject matter.
2. This document is protected by copyright and may only be reproduced and circulated in accordance with the Document Classification and associated conditions stipulated or referred to in this document and/or in DNV GL's written agreement with the Customer. No part of this document may be disclosed in any public offering memorandum, prospectus or stock exchange listing, circular or announcement without the express and prior written consent of DNV GL. A Document Classification permitting the Customer to redistribute this document shall not thereby imply that DNV GL has any liability to any recipient other than the Customer.
3. This document has been produced from information relating to dates and periods referred to in this document. This document does not imply that any information is not subject to change. Except and to the extent that checking or verification of information or data is expressly agreed within the written scope of its services, DNV GL shall not be responsible in any way in connection with erroneous information or data provided to it by the Customer or any third party, or for the effects of any such erroneous information or data whether or not contained or referred to in this document.
4. Any energy forecasts estimates or predictions are subject to factors not all of which are within the scope of the probability and uncertainties contained or referred to in this document and nothing in this document guarantees any particular wind speed or energy output.

KEY TO DOCUMENT CLASSIFICATION

Strictly Confidential	:	For disclosure only to named individuals within the Customer's organization.
Private and Confidential	:	For disclosure only to individuals directly concerned with the subject matter of the document within the Customer's organization.
Commercial in Confidence	:	Not to be disclosed outside the Customer's organization.
DNV GL only	:	Not to be disclosed to non-DNV GL staff
Customer's Discretion	:	Distribution for information only at the discretion of the Customer (subject to the above Important Notice and Disclaimer and the terms of DNV GL's written agreement with the Customer).
Published	:	Available for information only to the general public (subject to the above Important Notice and Disclaimer).

Project name:	Romney Wind Energy Centre	DNV GL - Energy
Report title:	Renewable Energy Approval Application - Noise Impact Assessment	Advisory Americas
Customer:	Romney Energy Centre Limited Partnership	4100 Molson, suite 100, Montreal, Quebec CANADA
Contact person:	Mark Gallagher	Phone: (514) 272-2175
Date of issue:	17 January 2018	Enterprise No.: 860480037
Project No.:	10021083	
Document No.:	10021083-CAMO-R-01	
Issue/Status	G/Final	

Prepared by:	Verified by:	Approved by:
--------------	--------------	--------------



A. Nercessian
Project Analyst, Development and
Engineering Services

L. Breadner
GIS, Environmental and Permitting
Services

S. Dokouzian, P.Eng.
Senior Project Engineer, Development
and Engineering Services

Project Proponent:

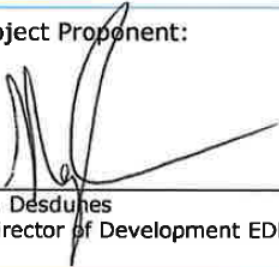

S. Desdunes
Director of Development EDF-EN

- Strictly Confidential
- Private and Confidential
- Commercial in Confidence
- DNV GL only
- Customer's Discretion
- Published

Keywords:
Noise Impact Assessment,
Wind Energy,
Advisory Americas

© 2018 GL Garrad Hassan Canada, Inc.. All rights reserved.

Reference to part of this report which may lead to misinterpretation is not permissible.

Issue	Date	Reason for Issue	Prepared by	Verified by	Approved by
A	18 January 2017	Original Release for Draft Site Plan	A. Nercessian	L. Breadner	S. Dokouzian
B	6 June 2017	Project Updates	A. Nercessian	L. Breadner	S. Dokouzian
C	27 July 2017	REA submission	A. Nercessian	L. Breadner	S. Dokouzian
D	18 August 2017	Replace S02 with S03	A. Nercessian	L. Breadner	S. Dokouzian
E	15 September 2017	MOECC comments	A. Nercessian	L. Breadner	S. Dokouzian
F	11 October 2017	Update transformer model. Revert back to S02.	A. Nercessian	L. Breadner	S. Dokouzian
G	17 January 2018	Fixed error in Table 4-1	A. Nercessian	L. Breadner	S. Dokouzian



Table of contents

1 INTRODUCTION	1
2 GENERAL DESCRIPTION OF PROJECT SITE	2
2.1 General characteristics	2
2.2 Land use description	2
2.3 Points of reception	3
3 DESCRIPTION OF POINTS OF RECEPTION	4
3.1 Receptor classes	4
3.2 Determination of applicable noise limits	4
4 DESCRIPTION OF SOURCES	6
4.1 Turbine description	6
4.2 Substation	6
4.3 Adjacent wind farms	7
4.4 Sound barrier	8
5 NOISE EMISSION RATINGS	10
5.1 Romney turbines	10
5.2 Adjacent wind farm turbines	17
5.3 Romney substation transformer	30
6 NOISE IMPACT ASSESSMENT	32
6.1 Evaluation of site topography	33
7 NOISE IMPACT ASSESSMENT RESULTS	35
8 CONCLUSION	53
9 REFERENCES	54

List of appendices

APPENDIX A – COORDINATES OF POINTS OF RECEPTION

APPENDIX B – COORDINATES OF PARTICIPANTS

APPENDIX C – NOISE ISO-CONTOUR MAPS

APPENDIX D – SAMPLE CALCULATION FOR NOISE MODELING

APPENDIX E – TURBINE NOISE SPECIFICATIONS

APPENDIX F – COORDINATES OF TURBINES AND TRANSFORMER

APPENDIX G – ROMNEY EXAMPLE TRANSFORMER DIAGRAM

List of tables

Table 3-1 Summary of noise limits for points of reception (Class 3)	5
Table 4-1 Summary of turbine models used at the Romney site	6
Table 4-2 Turbine models used at adjacent wind projects	7
Table 4-3 Romney substation barrier coordinates.....	8
Table 5-1 Vestas V136 3.6 STE Mode P01 wind turbine acoustic emission summary	11
Table 5-2 Effective Modelled Wind Turbine Acoustic Emissions at Hub Height (P01).....	12
Table 5-3 Vestas V136 3.45 STE Mode S01 wind turbine acoustic emission summary	13
Table 5-4 Effective Modelled Wind Turbine Acoustic Emissions at Hub Height (S01).....	14
Table 5-5 Vestas V136 3.45 STE Mode S02 wind turbine acoustic emission summary	15
Table 5-6 Effective Modelled Wind Turbine Acoustic Emissions at Hub Height (S02).....	16
Table 5-7 Vestas V90-1.8 High Power wind turbine acoustic emission summary	18
Table 5-8 Vestas V90-1.8 Standard Mode wind turbine acoustic emission summary	19
Table 5-9 Enercon E82 wind turbine acoustic emission summary	20
Table 5-10 Siemens SWT 2.3-101 wind turbine acoustic emission summary (Comber)	21
Table 5-11 Siemens SWT 2.221-101 wind turbine acoustic emission summary	22
Table 5-12 Siemens SWT 2.126-101 wind turbine acoustic emission summary	23
Table 5-13 Siemens SWT 1.903-101 wind turbine acoustic emission summary	24
Table 5-14 Siemens SWT 1.824-101 wind turbine acoustic emission summary	25
Table 5-15 Siemens SWT 2.2 93 wind turbine acoustic emission summary	26
Table 5-16 Siemens SWT 2.2 101 wind turbine acoustic emission summary	27
Table 5-17 Siemens SWT 2.3 93 wind turbine acoustic emission summary	28
Table 5-18 Siemens SWT 2.3-101 wind turbine acoustic emission summary	29
Table 5-19 Romney transformer sound power level calculation summary	30
Table 5-20 Romney Wind Energy Centre substation transformer sound power level.....	30
Table 5-21 Romney transformer octave band calculation details	31
Table 7-1 Noise impact assessment summary	36
Table 7-2 Noise impact assessment summary – participants	47
Table 7-3 Concordance table showing contributions from Romney and Chatham at shared receptors	48
Table 7-4 Concordance table showing contributions from Romney and Comber at shared receptors	50
Table 7-5 Concordance table for the Romney transformer and neighboring projects at shared receptors	52

List of figures

Figure 2-1 Sample photo of the Project area	2
Figure 2-2 Annual Wind Rose	3
Figure 4-1 Romney acoustic barrier and gravel area dimensions	9
Figure 6-1 Diagram of multiple reflection paths for sound propagation across concave ground.....	33
Figure 6-2 Topographic profile between Richardson Turbine 4 and Receptor R260	34

1 INTRODUCTION

GL Garrad Hassan Canada, Inc. (“DNV GL”) was retained by Romney Energy Centre Limited Partnership (the “Proponent” or “EDF”) to prepare a Noise Impact Assessment (NIA) of the Romney Wind Energy Centre (the “Project”) in accordance with the *Ontario Regulation (O. Reg.) 359/09* (Renewable Energy Approvals [REA] under Part V.0.1 of the Ontario Environmental Protection Act [EPA]) [1]. The Proponent was awarded a contract for this Project in March 2016 from the Independent Electricity System Operator (IESO) under the Large Renewable Procurement (LRP), and is seeking a Renewable Energy Approval (REA) from the Ontario Ministry of the Environment and Climate Change (MOECC). The Project will be owned and operated by Romney Energy Centre Limited Partnership, a partnership between Électricité de France Énergies Nouvelles Canada (EDF EN) and Aamjiwnaang First Nation. The Municipality of Chatham-Kent has also been provided with an option to participate in the Project.

This NIA also follows the MOECC 2016 Noise Guidelines for Wind Farms [2] (the “Noise Guidelines”), with special consideration to the transition rules for LRP1 projects set forth therein.

The proposed Project is located in the Municipalities of Chatham-Kent and Lakeshore, Ontario, approximately 30 km southwest of the City of Chatham. The layout being evaluated was provided by the Proponent [3] and consists of 17 primary wind turbine locations and 1 alternate location. The current layout, including the alternate location, has a nameplate capacity of 63.8 MW. DNV GL notes that the anticipated and final nameplate capacity of the Project is estimated to be no more than 60 MW, for a maximum of up to 17 wind turbines. The proposed layout contains three different Vestas wind turbine noise operation modes. The substation transformer location has been determined and it has been included in this assessment despite being located over 5 km from the Project turbines.

The objective of this assessment is twofold:

1. Confirm the sound level limit requirements for the Project by providing an assessment of the existing baseline environmental noise conditions in the vicinity of the wind farm; and
2. Predict the noise levels generated by the Project at all Points of Reception (PoR) and Participants within 1,500 m of the Project turbines and 1,000 m of the Project transformer.

2 GENERAL DESCRIPTION OF PROJECT SITE

2.1 General characteristics

A map of the Project area is shown in Appendix C. Project components will be installed on privately owned agricultural lots within the area. Energy generated by the Project will be collected via overhead or underground cabling and directed to an on-site substation.

The Project lies on predominantly flat, open, agricultural lands that include various natural features such as woodlands.

2.2 Land use description

The development pattern is typical of most rural areas in southern Ontario with dwellings built near the roadways. The Project area is dotted with residential farm houses and related buildings. There are seven wind farms in operation within 5 km of the Project area. The zoning map index can be found on the Municipality of Chatham-Kent and Town of Lakeshore websites respectively [4][5]. Figure 2-1 presents typical views of the land and features of the Project area, including existing wind farms. Figure 2-2 presents the annual hub height wind rose of the Project, as provided by the Proponent.



Figure 2-1 Sample photo of the Project area

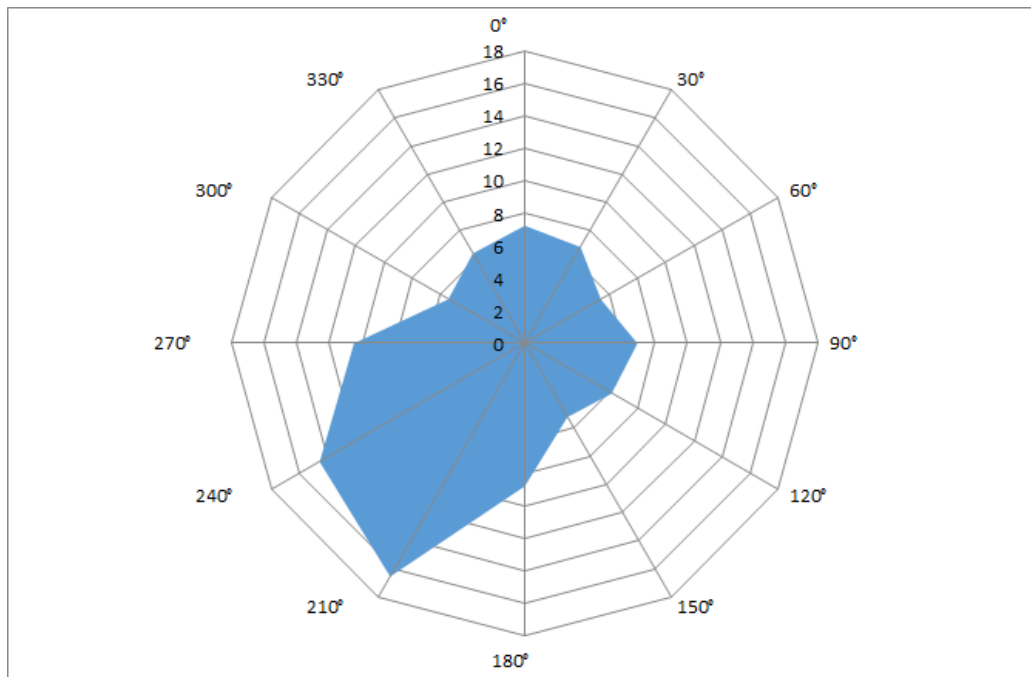

Figure 2-2 Annual Wind Rose

2.3 Points of reception

PoR locations for the Project, also referred to as receptors, were identified by DNV GL using base data from recent aerial photos and field reconnaissance completed in March 2015 to verify locations and building types. The height of each PoR, taken to be 1.5 m, 4.5 m, and 7.5 m for one, two, and three storey houses, respectively, was also noted. All PoR, as per the definition from the Noise Guidelines, were considered in this NIA. Building permits issued between February 2011 and December 2016 from the Municipality of Chatham-Kent, Lakeshore, and Leamington were reviewed to locate any receptors that could have been missed during the site visit.

The Noise Guidelines generally define a PoR as a house, campground, church, school or other sensitive building that is not located on the same premises as the wind farm, including its turbines and ancillary structures. A PoR can also be located on a vacant lot that has residence as a permitted use. DNV GL has identified Vacant Lot Receptors (VLR) on such lots in a location consistent with the building pattern in the area, as per the O. Reg. 359/09 and the Noise Guidelines.

A residence or VLR located on the same premises as the wind turbine(s) or other Project infrastructure is not a PoR as defined by the Noise Guidelines, and considered a "Participating Receptor" and thus MOECC noise limits do not apply.

The coordinates of all receptors and Participating Receptors are listed in Appendix A and Appendix B, respectively.

3 DESCRIPTION OF POINTS OF RECEPTION

There are 393 receptors located within 1,500 m of a Project wind turbine or 1,000 m of the substation transformer, among which 173 are VLRs. There are 25 Participants within this range, of which 8 are VLRs.

3.1 Receptor classes

The MOECC categorizes PoR into three classes: 1, 2, and 3. Class 1 refers to an acoustic environment typical of a major population centre where the background noise is dominated by the urban hum. These areas are highly urbanized and have moderate to high noise levels throughout the day and night. Class 2 areas have an acoustic environment characterized by low ambient sound levels between 19:00 and 07:00, whereby the evening and nighttime levels are defined by natural sounds, infrequent human activity and no clearly audible sounds from stationary sources (e.g., industrial and commercial facilities). Class 3 areas are typical of rural and/or small communities (i.e., with populations of less than 1000) and an acoustic environment that is dominated by natural sounds with little or no road traffic.

Within the study area the main sources of ambient sound that currently exist include:

- Vehicular traffic on the local concession and side roads, some of which are gravel roads;
- Occasional sounds due to logging and aggregate extraction activities;
- Occasional sounds due to anthropogenic domestic activities; and
- Natural sounds.

Based on these conditions, **all PoR are considered as having a Class 3 acoustic environment.**

3.2 Determination of applicable noise limits

As stated in the MOECC guidelines [2], the noise limits for a wind farm are set according to the Noise Guidelines in NPC-300 while taking into account the wind-generated background noise.

For a Class 3 area, the sound level limits as defined in the Noise Guidelines are described in the sections below.

3.2.1 Wind turbine installations in Class 3 areas (rural), wind speeds at or below 6 m/s

The lowest sound level limit expressed in terms of L_{eq} is: i) 40 dBA; or ii) the minimum hourly background sound level established in accordance with Publication NPC 300, whichever is higher.

3.2.2 Class 3 areas, wind speeds above 6 m/s

The lowest sound level limit expressed in terms of L_{eq} is: i) the wind-induced background sound level, expressed in terms of ninetieth percentile sound level (L_{A90}) plus 7 dB; or ii) the minimum hourly background sound level established in accordance with Publication NPC 300, whichever is higher.

The applicable noise limits should be those defined by the MOECC as summarized below in Table 3-1.

Table 3-1 Summary of noise limits for points of reception (Class 3)

Wind Turbine Noise Criterion [dBA]	Wind Speed at 10 m height [m/s]				
	≤6	7	8	9	≥10
	40	43	45	49	51

4 DESCRIPTION OF SOURCES

4.1 Turbine description

Three Vestas turbine models in different noise operational modes have been modeled in the current simulation, as described in Table 4-1. The proposed turbine models are all 3-bladed, upwind, horizontal-axis turbines, with serrated blade trailing edges. The rotor diameter of each wind turbine model is 136 m.

While the turbine model has not yet been finalized, the Proponent commits to building a final layout consisting of a total of 17 acoustically equivalent turbines, with an overall acoustical impact that will be lower or equal to the current simulation.

Table 4-1 Summary of turbine models used at the Romney site

Turbine model nameplate¹	Maximum rated power [kW]	Hub height [m]	Peak sound power level [dBA]	Peak modeled sound power level [dBA]	Number of turbines
Vestas V136 3.6 MW, Mode P01 STE	3600	132	105.5	106.0	11
Vestas V136 3.45 MW, Mode S01 STE	3450	132	104.7 ²	104.9	4
Vestas V136 3.45 MW, Mode S02 STE	3450	132	103.5	104.0	3
				Total	18

1 STE indicates that the turbines are equipped with serrated trailing edge blades

2 This value has been scaled to match the maximum measured sound power level according to the IEC test results of the S01 turbine presented under Appendix E

As described under Section 5.1, an upward adjustment varying from 0.2 dB to 0.5 dB has been added to every octave band sound power level of the three turbine modes for additional conservatism in the results.

Full noise specifications and measurement report summaries according to IEC 61400-11 Ed.3 for all considered turbines in Table 4-1, as provided by the manufacturer to the Proponent can be found in Appendix E. A letter from Vestas guaranteeing the above values and confirming the absence of audible tonality is also provided in Appendix E. Coordinates of all turbines are listed in Appendix F, including a description of which turbine model is used at each wind turbine location for the Project.

4.2 Substation

The Project includes one substation located in the Project Area and approximately 7 km north of the wind turbines. The substation is planned to include one transformer [3]. It is estimated that an area around the substation of up to approximately 7,000 m² will be covered with gravel, and has been included to the modeling. The estimated noise emissions of the Romney transformer are described in Section 5.3.

The transformer coordinates are included in Appendix F.

4.3 Adjacent wind farms

DNV GL has identified seven operational wind farms adjacent to the Project, as described in Table 4-2. These wind farms have turbines within 5 km of Romney receptors. All turbines and transformers from the adjacent wind farms have been considered as noise sources in this report.

Table 4-2 Turbine models used at adjacent wind projects

Adjacent project	Turbine type	Number of turbines	Turbine hub height [m]	Turbine broadband sound power level [dBA]
Richardson [7]	Enercon E-82	5	78	104.0
Gracey [7]	Enercon E-82	5	78	104.0
Pointe Aux Roches [6]	Vestas V90-1.8 high power control	21	80	104.5
	Vestas V90-1.8 standard	6	80	103.5
Port Alma [9]	Siemens SWT 2.3 93	44	80	105.1
Chatham [9]	Siemens SWT 2.3 101	26	80	106.0
	Siemens SWT 2.2 101	14	80	105.0
	Siemens SWT 2.2 93	4	80	104.0
Comber [8]	Siemens SWT 2.3 101	72	80	106.0
South Kent [7]	Siemens SWT 2.221 101	70	99	105.0
	Siemens SWT 2.126 101	52	99	104.0
	Siemens SWT 1.903 101	1	99	102.0
	Siemens SWT 1.824 101	1	99	101.0

The transformers of every project listed in Table 4-2 are confirmed to be located at distances greater than 5 km from the nearest Romney receptor and are therefore not included in this analysis.

4.4 Sound barrier

A sound barrier is planned for the Romney Wind Energy Centre substation. The type of barrier used in this noise study is one that can be described as of absorptive type with an Absorptive Coefficient of at least 0.8. The acoustic barriers will have a surface density of at least 20 kg/m² and have a closed surface free of gaps and cracks. A 3-sided barrier was modeled with a height of 6.0 m on the east side of the transformer and with a height of 5.0 m on the north and south sides. The barrier is several meters away from the transformer surface on each side, with an opening on the west side to allow for equipment access. The total barrier linear length is 25.5 m, as illustrated in Figure 4-1. The corner coordinates of the substation barrier are shown in Table 4-3.

Table 4-3 Romney substation barrier coordinates

Description	Easting [m]	Northing [m]
Barrier point 1	378767.0	4678192.5
Barrier point 2	378775.5	4678192.0
Barrier point 3	378775.0	4678183.5
Barrier point 4	378766.5	4678184.0



Figure 4-1 Romney acoustic barrier and gravel area dimensions

5 NOISE EMISSION RATINGS

5.1 Romney turbines

Guaranteed broadband sound power levels and third octave band sound power levels were provided by Vestas [10],[11] for each of the three wind turbine operational modes under consideration and are shown in Appendix E. Additionally, in Appendix E, sound power measurement report summaries are shown for mode P01, S01, and S02, and a letter guaranteeing the sound power levels and tonality of the three wind turbine modes. Values are presented per IEC 61400-11 Ed. 3 [12]. For each model, Vestas has provided third octave band sound power levels corresponding to hub height wind speeds¹ of up to 20 m/s.

DNV GL has determined that the octave band sound power levels corresponding to a hub height wind speed of 20 m/s produce the predictable worst-case noise impact for the standard and noise reduced Vestas wind turbine models. Additionally, DNV GL has applied an upward adjustment of up to 0.5 dB to every octave band sound power level of the three turbine models considered.

The adjusted 20 m/s octave band sound power levels of the standard turbine and the reduced noise mode turbines were used to calculate the predictable worst case sound levels at all receptors in this report.

The adjusted predictable worst case acoustic emissions of the three turbine operational modes under consideration are shown in Table 5-1 to Table 5-6.

¹ Vestas has not provided half integer wind speeds. Only integer wind speeds were provided in the published third octave band sound power level document.

Table 5-1 Vestas V136 3.6 STE Mode P01 wind turbine acoustic emission summary

Make and Model: Vestas V136										
Electrical Rating: 3.6 MW										
Hub Height (m): 132										
Wind Shear Coefficient: 0.36, Worst case summer night time shear of the region										
	Octave band sound power level [dB]									
	Manufacturer's emission levels*					Adjusted emission levels				
Wind speed [m/s]	16	17	18	19	20	6	7	8	9	10
Frequency [Hz]										
31.5	117.9	118.0	118.0	118.0	118.1	118.1	118.1	118.1	118.1	118.1
63	114.5	114.4	114.5	114.5	114.5	114.5	114.5	114.5	114.5	114.5
125	109.9	109.9	109.9	109.9	109.9	109.9	109.9	109.9	109.9	109.9
250	106.9	106.9	107.0	107.0	107.0	107.0	107.0	107.0	107.0	107.0
500	101.9	101.9	101.8	101.8	101.8	101.8	101.8	101.8	101.8	101.8
1000	99.7	99.7	99.6	99.6	99.6	99.6	99.6	99.6	99.6	99.6
2000	97.5	97.5	97.5	97.5	97.5	97.5	97.5	97.5	97.5	97.5
4000	90.6	90.6	90.6	90.6	90.6	90.6	90.6	90.6	90.6	90.6
8000	74.7	74.9	75.0	75.0	75.2	75.2	75.2	75.2	75.2	75.2
A-weighted	105.5	105.5	105.5	105.5	105.5	105.5	105.5	105.5	105.5	105.5

*Manufacturer's emission levels are referenced to hub height wind speeds and not 10m wind speeds.

Table 5-2 Effective Modelled Wind Turbine Acoustic Emissions at Hub Height (P01)

Make and Model:	Vestas V136 3.6 MW STE P01																												
Electrical Rating:	3600 kW																												
Hub Height (m):	132																												
Octave Band Sound Power Level (dB)																													
Manufacturer's Emission Levels at bin centre wind speeds at hub height																													
Wind Speeds at hub height (m/s)	8.0	8.5	9.0	9.5	10.0	10.5	11.0	11.5	12.0	12.5	13.0	13.5	14.0	14.5	15.0	15.5	16.0	16.5	17.0	17.5	18.0	18.5	19.0	19.5	20.0	(A) Manufacturer's Worst Case Spectrum (dB)	(B) Positive Overall Adjustment* (dB)	(A+B) Maximum Sound Power Level (dB)	
Frequency (Hz)																													
31.5	114.8	115.9	117.0	117.1	117.1	117.2	117.3	117.5	117.6	117.6	117.7	117.8	117.8	117.9	117.9	117.9	117.9	118.0	118.0	118.0	118.0	118.0	118.0	118.1	118.1	118.1	118.1	0.4	118.5
63	112.7	113.5	114.1	114.2	114.2	114.2	114.3	114.3	114.3	114.4	114.4	114.4	114.4	114.4	114.4	114.5	114.5	114.5	114.4	114.5	114.5	114.5	114.5	114.5	114.5	114.5	114.5	0.5	115.0
125	107.9	108.7	109.4	109.5	109.5	109.5	109.6	109.7	109.7	109.7	109.7	109.8	109.8	109.8	109.8	109.9	109.9	109.9	109.9	110.0	109.9	109.9	109.9	109.9	109.9	109.9	109.9		110.4
250	104.1	105.0	105.9	106.0	106.0	106.1	106.2	106.4	106.5	106.6	106.6	106.7	106.7	106.8	106.8	106.9	106.9	106.9	106.9	107.0	107.0	107.0	107.0	107.0	107.0	107.0	107.0		107.5
500	99.8	100.9	102.1	102.2	102.2	102.2	102.1	102.1	102.1	102.1	102.1	102.0	102.0	101.9	101.9	101.9	101.9	101.9	101.9	101.9	101.9	101.8	101.8	101.8	101.8	101.8	101.8		102.3
1,000	97.9	98.9	99.8	99.9	99.9	99.9	99.9	99.9	99.8	99.8	99.8	99.7	99.8	99.7	99.7	99.7	99.7	99.7	99.7	99.7	99.7	99.6	99.6	99.6	99.6	99.6	99.6		100.1
2,000	95.6	96.7	97.7	97.8	97.8	97.8	97.8	97.8	97.7	97.7	97.6	97.6	97.5	97.5	97.5	97.5	97.5	97.5	97.5	97.5	97.5	97.5	97.5	97.5	97.5	97.5	97.5		98.0
4,000	88.0	89.1	90.1	90.2	90.2	90.3	90.3	90.4	90.5	90.5	90.5	90.5	90.6	90.6	90.6	90.6	90.6	90.6	90.6	90.6	90.6	90.6	90.6	90.6	90.6	90.6	90.6	91.1	
8,000	70.9	71.8	72.6	72.7	72.7	73.0	73.2	73.6	73.8	74.0	74.1	74.3	74.5	74.6	74.6	74.7	74.7	74.8	74.9	75.0	75.0	75.0	75.0	75.1	75.2	75.2	0.4	75.6	
Overall A-weighted (dBA)	103.4	104.4	105.4	105.5	105.5	105.5	105.5	105.5	105.5	105.5	105.5	105.5	105.5	105.5	105.5	105.5	105.5	105.5	105.5	105.5	105.5	105.5	105.5	105.5	105.5	105.5	0.5	106.0	

* An upward adjustment of 0.4 dB or 0.5 dB has been added to the turbine sound power levels. The measurement uncertainty was not added in accordance to the Transition Rules for LRP 1 projects in the Noise Guidelines.

Table 5-3 Vestas V136 3.45 STE Mode S01 wind turbine acoustic emission summary

Make and Model: Vestas V136										
Electrical Rating: 3.45 MW										
Hub Height (m): 132										
Wind Shear Coefficient: 0.36, Worst case summer night time shear of the region										
	Octave band sound power level [dB]									
	Manufacturer's emission levels*					Adjusted emission levels				
Wind speed [m/s]	16	17	18	19	20	6	7	8	9	10
Frequency [Hz]										
31.5	117.1	117.1	117.2	117.2	117.2	117.2	117.2	117.2	117.2	117.2
63	113.7	113.6	113.7	113.7	113.7	113.7	113.7	113.7	113.7	113.7
125	109.1	109.1	109.1	109.1	109.1	109.1	109.1	109.1	109.1	109.1
250	106.1	106.1	106.2	106.2	106.2	106.2	106.2	106.2	106.2	106.2
500	101.1	101.1	101.0	101.0	101.0	101.0	101.0	101.0	101.0	101.0
1000	98.9	98.9	98.8	98.9	98.8	98.8	98.8	98.8	98.8	98.8
2000	96.7	96.7	96.7	96.7	96.7	96.7	96.7	96.7	96.7	96.7
4000	89.8	89.8	89.8	89.8	89.8	89.8	89.8	89.8	89.8	89.8
8000	73.9	74.1	74.3	74.2	74.3	74.3	74.3	74.3	74.3	74.3
A-weighted	104.7	104.7	104.7	104.7	104.7	104.7	104.7	104.7	104.7	104.7

*Manufacturer's emission levels are referenced to hub height wind speeds and not 10 m wind speeds. Octave band sound levels have been scaled up to meet the maximum measured sound power level of 104.7 dBA of the IEC test results in Appendix E.

Table 5-4 Effective Modelled Wind Turbine Acoustic Emissions at Hub Height (S01)

Make and Model:	Vestas V136 3.45 MW STE S01																														
Electrical Rating:	3450 kW																														
Hub Height (m):	132																														
Octave Band Sound Power Level (dB)																															
Manufacturer's Emission Levels at bin centre wind speeds at hub height																															
Wind Speeds at hub height (m/s)	8.0	8.5	9.0	9.5	10.0	10.5	11.0	11.5	12.0	12.5	13.0	13.5	14.0	14.5	15.0	15.5	16.0	16.5	17.0	17.5	18.0	18.5	19.0	19.5	20.0	(A) Manufacturer's Worst Case Spectrum (dB)	(B) Positive Overall Adjustment* (dB)	(A+B) Maximum Sound Power Level (dB)			
Frequency (Hz)																															
31.5	108.6	109.2	116.1	116.2	116.2	116.4	116.5	116.7	116.8	116.8	116.9	117.0	117.0	117.1	117.1	117.1	117.1	117.1	117.1	117.1	117.2	117.2	117.2	117.2	117.2	117.2	117.2	117.2	117.2	0.2	117.4
63	107.2	107.6	113.8	113.8	113.7	113.7	113.7	113.7	113.7	113.7	113.7	113.7	113.6	113.6	113.6	113.7	113.7	113.7	113.6	113.7	113.7	113.7	113.7	113.7	113.7	113.7	113.7	113.7	113.7		113.9
125	102.4	102.8	108.9	109.0	109.0	109.0	109.0	109.0	109.0	109.0	109.0	109.0	109.0	109.0	109.0	109.1	109.1	109.1	109.1	109.1	109.1	109.1	109.1	109.1	109.1	109.1	109.1	109.1	109.1		109.3
250	100.0	100.5	105.2	105.2	105.2	105.4	105.6	105.7	105.8	105.9	105.9	105.9	105.9	106.0	106.0	106.1	106.1	106.1	106.1	106.1	106.2	106.2	106.2	106.2	106.2	106.2	106.2	106.2	106.2		106.4
500	95.6	96.3	101.2	101.3	101.2	101.2	101.2	101.2	101.1	101.2	101.1	101.1	101.1	101.1	101.1	101.1	101.1	101.1	101.1	101.1	101.1	101.0	101.0	101.0	101.0	101.0	101.0	101.0	101.0		101.2
1,000	93.5	93.9	99.2	99.2	99.2	99.2	99.1	99.1	99.0	99.0	98.9	99.0	98.9	98.9	98.9	98.9	98.9	98.9	98.9	98.9	98.9	98.8	98.9	98.9	98.9	98.8	98.8	98.8	98.8		99.0
2,000	90.9	91.5	97.0	97.0	97.0	97.0	96.9	96.9	96.8	96.8	96.8	96.8	96.7	96.7	96.7	96.7	96.7	96.7	96.7	96.7	96.7	96.7	96.7	96.7	96.7	96.7	96.7	96.7	96.7		96.9
4,000	82.2	82.7	89.4	89.4	89.4	89.5	89.6	89.6	89.6	89.7	89.7	89.8	89.8	89.8	89.8	89.8	89.8	89.8	89.8	89.8	89.8	89.8	89.8	89.8	89.8	89.8	89.8	89.8	89.8		90.0
8,000	62.5	62.7	71.9	72.0	72.0	72.4	72.8	73.0	73.2	73.4	73.5	73.5	73.6	73.7	73.8	73.9	73.9	74.0	74.1	74.2	74.3	74.3	74.2	74.3	74.3	74.3	74.3	74.3	74.3		74.5
Overall A-weighted (dBA)	103.0	103.6	104.7	104.7	104.7	104.7	104.7	104.7	104.7	104.7	104.7	104.7	104.7	104.7	104.7	104.7	104.7	104.7	104.7	104.7	104.7	104.7	104.7	104.7	104.7	104.7	104.7	104.7	104.7		0.2

* An upward adjustment of 0.2 dB has been added to the turbine sound power levels. The measurement uncertainty was not added in accordance to the Transition Rules for LRP 1 projects in the Noise Guidelines.

Table 5-5 Vestas V136 3.45 STE Mode S02 wind turbine acoustic emission summary

Make and Model: Vestas V136										
Electrical Rating: 3.45 MW										
Hub Height (m): 132										
Wind Shear Coefficient: 0.36, Worst case summer night time shear of the region										
	Octave band sound power level [dB]									
	Manufacturer's emission levels*					Adjusted emission levels				
Wind speed [m/s]	16	17	18	19	20	6	7	8	9	10
Frequency [Hz]										
31.5	115.9	115.9	116.0	116.0	116.0	116.0	116.0	116.0	116.0	116.0
63	112.5	112.5	112.5	112.5	112.5	112.5	112.5	112.5	112.5	112.5
125	107.9	107.9	107.9	107.9	107.9	107.9	107.9	107.9	107.9	107.9
250	104.9	104.9	105.0	105.0	105.0	105.0	105.0	105.0	105.0	105.0
500	99.9	99.9	99.8	99.8	99.8	99.8	99.8	99.8	99.8	99.8
1000	97.7	97.7	97.6	97.7	97.6	97.6	97.6	97.6	97.6	97.6
2000	95.5	95.5	95.5	95.5	95.5	95.5	95.5	95.5	95.5	95.5
4000	88.6	88.6	88.6	88.6	88.6	88.6	88.6	88.6	88.6	88.6
8000	72.7	72.9	73.1	73.0	73.1	73.1	73.1	73.1	73.1	73.1
A-weighted	103.5	103.5	103.5	103.5	103.5	103.5	103.5	103.5	103.5	103.5

*Manufacturer's emission levels are referenced to hub height wind speeds and not 10m wind speeds.

In order to explain how turbine modes S01 and S02 achieve the same rated output at high wind speeds but produce different sound power levels, Vestas provided the following explanation:

Peak sound emissions occur near the knee of the power curve, where the turbine in standard operation reaches rated power (i.e. rated wind speed). Above this knee, the turbine is operating at reduced efficiency, dumping energy by pitching out, reducing tip speed, or a combination of both, in order to reduce loads on the turbine components. In sound, optimized operation, the tip speed and blade pitch schedule is altered such that peak sound emission are reduced at the standard rated wind speed yet the standard power rating is achieved at a higher wind speed. These improvements are possible up to a threshold of pitch and RPM control, as evidenced in modes S01 and S02, but eventually, as the turbine is further curtailed, rated power cannot be achieved before cut-out as seen in mode S03.

Table 5-6 Effective Modelled Wind Turbine Acoustic Emissions at Hub Height (S02)

Make and Model:	Vestas V136 3.45 MW STE S02																																	
Electrical Rating:	3450 kW																																	
Hub Height (m):	132																																	
Octave Band Sound Power Level (dB)																																		
Manufacturer's Emission Levels at bin centre wind speeds at hub height																																		
Wind Speeds at hub height (m/s)	8.0	8.5	9.0	9.5	10.0	10.5	11.0	11.5	12.0	12.5	13.0	13.5	14.0	14.5	15.0	15.5	16.0	16.5	17.0	17.5	18.0	18.5	19.0	19.5	20.0	(A) Manufacturer's Worst Case Spectrum (dB)	(B) Positive Overall Adjustment* (dB)	(A+B) Maximum Sound Power Level (dB)						
Frequency (Hz)																																		
31.5	114.3	114.5	114.7	114.8	114.9	115.1	115.2	115.4	115.5	115.6	115.7	115.7	115.8	115.8	115.9	115.9	115.9	115.9	115.9	116.0	116.0	116.0	116.0	116.0	116.0	116.0	116.0	116.0	116.0	116.0	116.0	116.0	116.5	
63	112.5	112.6	112.8	112.8	112.7	112.8	112.7	112.7	112.7	112.6	112.6	112.6	112.6	112.6	112.5	112.5	112.5	112.5	112.5	112.5	112.5	112.5	112.5	112.5	112.5	112.5	112.5	112.5	112.5	112.5	112.5	112.5	112.5	113.0
125	107.6	107.8	108.0	108.0	107.9	108.0	107.9	107.9	107.9	107.9	107.9	107.9	107.9	107.9	107.9	107.9	107.9	107.9	107.9	107.9	107.9	107.9	107.9	107.9	107.9	107.9	107.9	107.9	107.9	107.9	107.9	107.9	108.4	
250	103.7	103.8	104.0	104.0	104.1	104.3	104.4	104.5	104.6	104.7	104.7	104.8	104.8	104.8	104.8	104.9	104.9	104.9	104.9	104.9	105.0	105.0	105.0	105.0	105.0	105.0	105.0	105.0	105.0	105.0	105.0	105.0	105.5	
500	99.3	99.7	100.0	100.0	99.9	99.9	99.9	99.9	99.9	99.9	99.9	99.9	99.9	99.9	99.9	99.9	99.9	99.9	99.9	99.9	99.9	99.8	99.8	99.8	99.8	99.8	99.8	99.8	99.8	99.8	99.8	99.8	100.3	
1,000	97.5	97.8	98.1	98.1	98.0	98.0	97.9	97.9	97.8	97.8	97.8	97.8	97.7	97.7	97.7	97.8	97.7	97.7	97.7	97.7	97.7	97.6	97.7	97.7	97.7	97.6	97.6	97.6	97.6	97.6	97.6	97.6	98.1	
2,000	95.2	95.5	95.7	95.7	95.7	95.7	95.6	95.6	95.6	95.6	95.6	95.6	95.5	95.5	95.5	95.5	95.5	95.5	95.5	95.5	95.5	95.5	95.5	95.5	95.5	95.5	95.5	95.5	95.5	95.5	95.5	95.5	96.0	
4,000	87.6	87.9	88.1	88.1	88.1	88.2	88.3	88.4	88.4	88.4	88.4	88.5	88.5	88.5	88.5	88.6	88.6	88.6	88.6	88.6	88.6	88.6	88.6	88.6	88.6	88.6	88.6	88.6	88.6	88.6	88.6	88.6	89.1	
8,000	70.7	70.7	70.7	70.8	70.9	71.3	71.6	71.9	72.1	72.2	72.3	72.4	72.5	72.5	72.5	72.6	72.7	72.8	72.9	73.0	73.1	73.1	73.0	73.1	73.1	73.1	73.1	73.1	73.1	73.1	73.1	73.6		
Overall A-weighted (dBA)	103.0	103.3	103.5	103.5	103.5	103.5	103.5	103.5	103.5	103.5	103.5	103.5	103.5	103.5	103.5	103.5	103.5	103.5	103.5	103.5	103.5	103.5	103.5	103.5	103.5	103.5	103.5	103.5	103.5	103.5	103.5	104.0		

* An upward adjustment of 0.5 dB has been added to the turbine sound power levels. The measurement uncertainty was not added in accordance to the Transition Rules for LRP 1 projects in the Noise Guidelines.



5.2 Adjacent wind farm turbines

Noise emissions from seven adjacent wind farms have been considered in this analysis. In accordance with the transition rules for LRP1 projects set forth in the Noise Guidelines, a positive uncertainty has not been applied on the sound power levels.

5.2.1 Pointe aux Roches Wind Farm

The Pointe aux Roches Wind Farm consists of 27 Vestas V90-1.8 turbines. Two modes of operation are in use: Standard Mode and High Power Mode. Each turbine operates in one mode. Twenty-one turbines operate in High Power Mode, while six operate in Standard Mode. The turbine locations and modes are included in Appendix F.

Broadband and octave band sound power levels for the High Power mode were obtained from the Pointe-Aux-Roches noise report [6] and are summarized in Table 5-7 and Table 5-8.

The octave band sound power levels corresponding to 10 m wind speeds of 8 to 10 m/s correspond to the highest broadband sound power level. These were used in the Pointe-Aux-Roches noise report, and for all calculations in the current analysis.

Table 5-7 Vestas V90-1.8 High Power wind turbine acoustic emission summary

Make and Model: Vestas V90-1.8, High Power mode										
Electrical Rating: 1.8 MW										
Hub Height (m): 80 m										
Wind Shear Coefficient: 0.36, Worst case summer night time shear in the region										
	Octave band sound power level [dB]									
	Manufacturer's emission levels					Adjusted emission levels				
Wind speed [m/s]	6	7	8	9	10	6	7	8	9	10
Frequency [Hz]										
31.5	112.1	114.8	115.8	115.8	115.8	115.8	115.8	115.8	115.8	115.8
63	107.6	110.8	112.6	112.6	112.6	112.6	112.6	112.6	112.6	112.6
125	106.3	108.9	109.7	109.7	109.7	109.7	109.7	109.7	109.7	109.7
250	100.7	102.6	103.3	103.3	103.3	103.3	103.3	103.3	103.3	103.3
500	98.9	100.5	101.2	101.2	101.2	101.2	101.2	101.2	101.2	101.2
1000	96.8	98.5	98.5	98.5	98.5	98.5	98.5	98.5	98.5	98.5
2000	94.4	95.7	96.1	96.1	96.1	96.1	96.1	96.1	96.1	96.1
4000	91.8	93.6	94.2	94.2	94.2	94.2	94.2	94.2	94.2	94.2
8000	82.5	85.5	85.7	85.7	85.7	85.7	85.7	85.7	85.7	85.7
A-weighted	102.3	104.0	104.5	104.5	104.5	104.5	104.5	104.5	104.5	104.5

Table 5-8 Vestas V90-1.8 Standard Mode wind turbine acoustic emission summary

Make and Model: Vestas V90-1.8, Standard Mode										
Electrical Rating: 1.8 MW										
Hub Height (m): 80 m										
Wind Shear Coefficient: 0.36, Worst case summer night time shear in the region										
	Octave Band Sound Power Level [dB]									
	Manufacturer's Emission Levels					Adjusted Emission Levels				
Wind Speed [m/s]	6	7	8	9	10	6	7	8	9	10
Frequency [Hz]										
63	110.5	111.9	111.8	110.8	111.5	111.5	111.5	111.5	111.5	111.5
125	104.9	106.4	106.3	106.3	106.1	106.1	106.1	106.1	106.1	106.1
250	100.7	101.6	101.4	100.5	100.9	100.9	100.9	100.9	100.9	100.9
500	97.7	97.9	98.4	97.8	97.9	97.9	97.9	97.9	97.9	97.9
1000	97.2	97.8	98.1	96.8	97.8	97.8	97.8	97.8	97.8	97.8
2000	94.4	95.1	95.8	94.8	95.8	95.8	95.8	95.8	95.8	95.8
4000	92.6	93.8	94.5	97.3	95.0	95.0	95.0	95.0	95.0	95.0
8000	85.8	89.2	89.9	90.7	92.5	92.5	92.5	92.5	92.5	92.5
A-weighted	102.3	103.1	103.5	103.5	103.5	103.5	103.5	103.5	103.5	103.5

5.2.2 Gracey and Richardson Wind Farms

The Gracey and Richardson wind farms each consist of five Enercon E-82 turbines. The turbine locations are included in Appendix F. Broadband and octave band sound power levels for each mode were obtained from the South Kent noise report's adjacent wind farm section [7], which provide more up-to-date information compared to the original noise reports, and are summarized in Table 5-9. The octave band sound power levels corresponding to 10 m wind speeds of 8 to 10 m/s correspond to the highest broadband sound power level. Therefore, the 8-10 m/s levels were used in the current analysis.

Table 5-9 Enercon E82 wind turbine acoustic emission summary

Make and Model: Enercon E-82										
Electrical Rating: 2.0 MW										
Hub Height (m): 78 m										
Wind Shear Coefficient: 0.36, Worst case summer night time shear in the region										
	Octave band sound power level [dB]									
	Manufacturer's emission levels					Adjusted emission levels				
Wind speed [m/s]	6	7	8	9	10	6	7	8	9	10
Frequency [Hz]										
63	108.3	110.5	110.9	110.9	110.9	110.9	110.9	110.9	110.9	110.9
125	103.8	106.2	108.3	108.3	108.3	108.3	108.3	108.3	108.3	108.3
250	102.8	104.8	103.6	103.6	103.6	103.6	103.6	103.6	103.6	103.6
500	99.1	101.5	101.5	101.5	101.5	101.5	101.5	101.5	101.5	101.5
1000	95.3	98.5	100.0	100.0	100.0	100.0	100.0	100.0	100.0	100.0
2000	87.8	91.3	93.6	93.6	93.6	93.6	93.6	93.6	93.6	93.6
4000	77.0	80.2	82.1	82.1	82.1	82.1	82.1	82.1	82.1	82.1
8000	78.4	78.8	79.3	79.3	79.3	79.3	79.3	79.3	79.3	79.3
A-weighted	100.7	103.3	104.0	104.0	104.0	104.0	104.0	104.0	104.0	104.0

5.2.3 Comber Wind Farm

The Comber Wind Farm located immediately northwest of the Project turbines is owned and operated by Brookfield Power and consists of 72 Siemens SWT 2.3-101 turbines at a hub height of 80 m located in Lakeshore. The turbine locations are included in Appendix F. Broadband and octave band sound power levels for each mode were obtained from the Comber noise report [8] and are summarized in Table 5-10.

Table 5-10 Siemens SWT 2.3-101 wind turbine acoustic emission summary (Comber)

Make and Model: SWT 2.3 101										
Electrical Rating: 2.3										
Hub Height (m): 80										
Wind Shear Coefficient: 0.36, Worst case summer night time shear in the region										
	Octave band sound power level [dB]									
	Manufacturer's emission levels					Adjusted emission levels				
Wind speed [m/s]	6	7	8	9	10	6	7	8	9	10
Frequency [Hz]										
63	106.8	108.7	108.7	108.7	108.7	108.7	108.7	108.7	108.7	108.7
125	107.9	109.5	109.5	109.5	109.5	109.5	109.5	109.5	109.5	109.5
250	104.5	105.7	105.7	105.7	105.7	105.7	105.7	105.7	105.7	105.7
500	102.7	104.3	104.3	104.3	104.3	104.3	104.3	104.3	104.3	104.3
1000	99.7	101.1	101.1	101.1	101.1	101.1	101.1	101.1	101.1	101.1
2000	95.1	96.2	96.2	96.2	96.2	96.2	96.2	96.2	96.2	96.2
4000	87.9	89.2	89.2	89.2	89.2	89.2	89.2	89.2	89.2	89.2
8000	85.7	87.3	87.3	87.3	87.3	87.3	87.3	87.3	87.3	87.3
A-weighted	104.6	106.0	106.0	106.0	106.0	106.0	106.0	106.0	106.0	106.0

5.2.4 South Kent Wind Farm

The South Kent turbine consists of a total of 124 Siemens SWT 101 turbines with four different noise operational modes and capacities. The turbine locations are included in Appendix F. Broadband and octave band sound power levels for each mode were obtained from the South Kent noise report [7], and are summarized in Table 5-11 to Table 5-14.

Table 5-11 Siemens SWT 2.221-101 wind turbine acoustic emission summary

Make and Model: SWT 2.221 101										
Electrical Rating: 2.221										
Hub Height (m): 80										
Wind Shear Coefficient: 0.36, Worst case summer night time shear in the region										
	Octave band sound power level [dB]									
	Manufacturer's emission levels					Adjusted emission levels				
Wind speed [m/s]	6	7	8	9	10	6	7	8	9	10
Frequency [Hz]										
63	112.5	112.2	111.0	111.1	110.7	112.2	112.2	112.2	112.2	112.2
125	106.4	107.7	107.2	106.6	105.7	107.7	107.7	107.7	107.7	107.7
250	105.1	106.1	105.0	104.3	103.5	106.1	106.1	106.1	106.1	106.1
500	100.9	101.5	100.4	100.2	99.8	101.5	101.5	101.5	101.5	101.5
1000	99.2	99.9	100.1	100.0	100.2	99.9	99.9	99.9	99.9	99.9
2000	95.3	96.0	97.7	97.8	98.2	96.0	96.0	96.0	96.0	96.0
4000	91.2	92.5	92.6	94.4	94.5	92.5	92.5	92.5	92.5	92.5
8000	78.2	79.0	81.9	81.8	81.6	79.0	79.0	79.0	79.0	79.0
A-weighted	104.2	105.0	105.0	105.0	105.0	105.0	105.0	105.0	105.0	105.0

Table 5-12 Siemens SWT 2.126-101 wind turbine acoustic emission summary

Make and Model: SWT 2.126 101										
Electrical Rating: 2.126										
Hub Height (m): 80										
Wind Shear Coefficient: 0.36, Worst case summer night time shear in the region										
	Octave band sound power level [dB]									
	Manufacturer's emission levels					Adjusted emission levels				
Wind speed [m/s]	6	7	8	9	10	6	7	8	9	10
Frequency [Hz]										
63	112.2	111.8	110.8	110.8	110.4	111.8	111.8	111.8	111.8	111.8
125	105.9	107.1	106.8	106.2	105.3	107.1	107.1	107.1	107.1	107.1
250	105.0	105.8	103.3	102.6	101.7	105.8	105.8	105.8	105.8	105.8
500	100.3	100.8	99.5	99.2	98.8	100.8	100.8	100.8	100.8	100.8
1000	97.7	98.3	99.3	99.2	99.3	98.3	98.3	98.3	98.3	98.3
2000	93.9	94.5	96.6	96.7	97.2	94.5	94.5	94.5	94.5	94.5
4000	90.6	91.8	91.5	93.3	93.4	91.8	91.8	91.8	91.8	91.8
8000	78.1	78.8	80.4	80.3	80.1	78.8	78.8	78.8	78.8	78.8
A-weighted	103.3	104.0	104.0	104.0	104.0	104.0	104.0	104.0	104.0	104.0

Table 5-13 Siemens SWT 1.903-101 wind turbine acoustic emission summary

Make and Model: SWT 1.903 101										
Electrical Rating: 1.903										
Hub Height (m): 80										
Wind Shear Coefficient: 0.36, Worst case summer night time shear in the region										
	Octave band sound power level [dB]									
	Manufacturer's emission levels					Adjusted emission levels				
Wind speed [m/s]	6	7	8	9	10	6	7	8	9	10
Frequency [Hz]										
63	111.7	111.3	110.4	110.5	110.2	111.3	111.3	111.3	111.3	111.3
125	105.1	105.9	106.1	106.0	105.6	105.9	105.9	105.9	105.9	105.9
250	104.2	103.9	103.0	102.8	102.2	103.9	103.9	103.9	103.9	103.9
500	98.4	98.0	97.0	96.8	96.4	98.0	98.0	98.0	98.0	98.0
1000	94.5	95.9	96.4	96.3	96.4	95.9	95.9	95.9	95.9	95.9
2000	91.4	93.6	94.6	94.7	95.2	93.6	93.6	93.6	93.6	93.6
4000	89.1	89.7	89.6	90.5	90.7	89.7	89.7	89.7	89.7	89.7
8000	77.6	79.1	79.7	79.9	79.9	79.1	79.1	79.1	79.1	79.1
A-weighted	101.4	102.0	102.0	102.0	102.0	102.0	102.0	102.0	102.0	102.0

Table 5-14 Siemens SWT 1.824-101 wind turbine acoustic emission summary

Make and Model: SWT 1.824 101										
Electrical Rating: 1.824										
Hub Height (m): 80										
Wind Shear Coefficient: 0.36, Worst case summer night time shear in the region										
	Octave band sound power level [dB]									
	Manufacturer's emission levels					Adjusted emission levels				
Wind speed [m/s]	6	7	8	9	10	6	7	8	9	10
Frequency [Hz]										
63	111.5	111.1	110.2	110.2	110.0	111.1	111.1	111.1	111.1	111.1
125	104.7	105.6	105.7	105.6	105.2	105.6	105.6	105.6	105.6	105.6
250	103.8	103.5	102.6	102.4	101.8	103.5	103.5	103.5	103.5	103.5
500	97.0	96.7	95.8	95.6	95.2	96.7	96.7	96.7	96.7	96.7
1000	92.8	94.4	95.0	94.9	95.1	94.4	94.4	94.4	94.4	94.4
2000	90.3	92.5	93.5	93.7	94.1	92.5	92.5	92.5	92.5	92.5
4000	88.2	88.7	88.6	89.4	89.7	88.7	88.7	88.7	88.7	88.7
8000	77.3	78.6	79.1	79.3	79.2	78.6	78.6	78.6	78.6	78.6
A-weighted	100.4	101.0	101.0	101.0	101.0	101.0	101.0	101.0	101.0	101.0

5.2.5 Port Alma and Chatham Wind Farms

The Port Alma and Chatham Wind farms, located east of the Project turbines, are owned and operated by Kruger, and consist of a total of 88 Siemens SWT 2.2 MW and 2.3 MW turbines with rotors of 93 m or 101 m. The coordinates of the turbines are shown in Appendix F. Broadband and octave band sound power levels for each mode were obtained from the KEC environmental noise impact assessment [9], which provides more up-to-date information on the Port Alma project, and are summarized in Table 5-15 to Table 5-18.

Table 5-15 Siemens SWT 2.2 93 wind turbine acoustic emission summary

Make and Model: SWT 2.2 93										
Electrical Rating: 2.2 MW										
Hub Height (m): 80										
Wind Shear Coefficient: 0.36, Worst case summer night time shear in the region										
	Octave band sound power level [dB]									
	Manufacturer's emission levels					Adjusted emission levels				
Wind speed [m/s]	6	7	8	9	10	6	7	8	9	10
Frequency [Hz]										
63	109.5	111.3	111.3	111.3	111.3	111.3	111.3	111.3	111.3	111.3
125	109.7	109.6	109.6	109.6	109.6	109.6	109.6	109.6	109.6	109.6
250	107.8	107.3	107.3	107.3	107.3	107.3	107.3	107.3	107.3	107.3
500	100.3	102.0	102.0	102.0	102.0	102.0	102.0	102.0	102.0	102.0
1000	93.2	96.5	96.5	96.5	96.5	96.5	96.5	96.5	96.5	96.5
2000	90.2	91.9	91.9	91.9	91.9	91.9	91.9	91.9	91.9	91.9
4000	85.8	87.6	87.6	87.6	87.6	87.6	87.6	87.6	87.6	87.6
8000	80.7	86.2	86.2	86.2	86.2	86.2	86.2	86.2	86.2	86.2
A-weighted	103.0	104.0	104.0	104.0	104.0	104.0	104.0	104.0	104.0	104.0

Table 5-16 Siemens SWT 2.2 101 wind turbine acoustic emission summary

Make and Model: SWT 2.2 101										
Electrical Rating: 2.2 MW										
Hub Height (m): 80										
Wind Shear Coefficient: 0.36, Worst case summer night time shear in the region										
	Octave band sound power level [dB]									
	Manufacturer's emission levels					Adjusted emission levels				
Wind speed [m/s]	6	7	8	9	10	6	7	8	9	10
Frequency [Hz]										
63	107.5	108.6	108.6	108.6	108.6	108.6	108.6	108.6	108.6	108.6
125	108.6	109.1	109.1	109.1	109.1	109.1	109.1	109.1	109.1	109.1
250	104.3	104.6	104.6	104.6	104.6	104.6	104.6	104.6	104.6	104.6
500	101.4	103.0	103.0	103.0	103.0	103.0	103.0	103.0	103.0	103.0
1000	98.3	100.1	100.1	100.1	100.1	100.1	100.1	100.1	100.1	100.1
2000	94.6	95.3	95.3	95.3	95.3	95.3	95.3	95.3	95.3	95.3
4000	87.0	88.6	88.6	88.6	88.6	88.6	88.6	88.6	88.6	88.6
8000	84.7	86.8	86.8	86.8	86.8	86.8	86.8	86.8	86.8	86.8
A-weighted	103.7	105.0	105.0	105.0	105.0	105.0	105.0	105.0	105.0	105.0

Table 5-17 Siemens SWT 2.3 93 wind turbine acoustic emission summary

Make and Model: SWT 2.3 93										
Electrical Rating: 2.3 MW										
Hub Height (m): 80										
Wind Shear Coefficient: 0.36, Worst case summer night time shear in the region										
	Octave band sound power level [dB]									
	Manufacturer's emission levels					Adjusted emission levels				
Wind speed [m/s]	6	7	8	9	10	6	7	8	9	10
Frequency [Hz]										
63	107.6	109.7	110.5	110.4	110.4	110.5	110.5	110.5	110.5	110.5
125	108.3	109.5	109.4	109.3	109.3	109.4	109.4	109.4	109.4	109.4
250	107.6	108.8	108.6	108.5	108.5	108.6	108.6	108.6	108.6	108.6
500	101.6	103.3	103.6	103.5	103.5	103.6	103.6	103.6	103.6	103.6
1000	94.7	96.8	97.5	97.4	97.4	97.5	97.5	97.5	97.5	97.5
2000	90.5	92.3	92.8	92.7	92.7	92.8	92.8	92.8	92.8	92.8
4000	87.2	88.1	87.7	87.6	87.6	87.7	87.7	87.7	87.7	87.7
8000	83.1	85.3	86.1	86.0	86.0	86.1	86.1	86.1	86.1	86.1
A-weighted	103.4	104.9	105.1	105.0	105.0	105.1	105.1	105.1	105.1	105.1

Table 5-18 Siemens SWT 2.3-101 wind turbine acoustic emission summary

Make and Model: SWT 2.3 101										
Electrical Rating: 2.3 MW										
Hub Height (m): 80										
Wind Shear Coefficient: 0.36, Worst case summer night time shear in the region										
	Octave band sound power level [dB]									
	Manufacturer's emission levels					Adjusted emission levels				
Wind speed [m/s]	6	7	8	9	10	6	7	8	9	10
Frequency [Hz]										
63	106.8	108.7	108.7	108.7	108.7	108.7	108.7	108.7	108.7	108.7
125	107.9	109.5	109.5	109.5	109.5	109.5	109.5	109.5	109.5	109.5
250	104.5	105.7	105.7	105.7	105.7	105.7	105.7	105.7	105.7	105.7
500	102.7	104.3	104.3	104.3	104.3	104.3	104.3	104.3	104.3	104.3
1000	99.7	101.1	101.1	101.1	101.1	101.1	101.1	101.1	101.1	101.1
2000	95.1	96.2	96.2	96.2	96.2	96.2	96.2	96.2	96.2	96.2
4000	87.9	89.2	89.2	89.2	89.2	89.2	89.2	89.2	89.2	89.2
8000	85.7	87.3	87.3	87.3	87.3	87.3	87.3	87.3	87.3	87.3
A-weighted	104.6	106.0	106.0	106.0	106.0	106.0	106.0	106.0	106.0	106.0

5.3 Romney substation transformer

The noise contribution of the Romney substation has been considered in this analysis. Noise emission from the Project substation mainly originates from one transformer. The transformer rating is estimated to be 75 MVA-230 kV. The choice of transformer has not yet been finalized, but will be sourced in accordance with permitted specifications.

The broadband sound power level of the Romney transformer has been calculated to be 103.5 dBA, based on a guaranteed audible noise level of 75 dBA. This also includes a 5 dBA tonal penalty, as prescribed in Publication NPC-104.

The transformer's measurement surface area, as defined in standard IEEE C57.12.90 [13], has been estimated to be 220 m². This calculation is based on an eight-sided polygon perimeter that includes a 2 m offset from all fan-cooled surfaces, as well as the top area of the measurement surface. A sketch of the plan view of the transformer, showing the approximate perimeter of the measurement surface area, is included in Appendix G. The substation coordinates are included in Appendix F.

The transformer's broadband sound power level L_W has been estimated as a function of its sound pressure level and measurement surface area using the following equation, as defined by IEEE C57.12.90.

$$L_W = L_p + 10 * \log S$$

A broadband sound power level of 103.5 dBA was used for the transformer for all noise modeling. The calculation of the broadband level is summarized in Table 5-19.

Table 5-19 Romney transformer sound power level calculation summary

Transformer Power Rating [MVA]	75
Transformer Voltage Rating [kV]	230
Sound Pressure Level L_p [dBA]	75
Sound measurement area S (m ²)	220
Sound Power Level [dBA] (without penalty)	98.5
Sound Power Level L_W [dBA] (with penalty)	103.5

Table 5-20 provides the octave band sound power levels of the Romney substation transformer using a typical octave band sound distribution for a large transformer [13], [14].

Table 5-21 details the octave band calculation. The transformer has been conservatively modeled as a point source at a height of 4.5 m.

Table 5-20 Romney Wind Energy Centre substation transformer sound power level

Frequency (Hz)	Octave band sound power level* (dBA)									Broadband (dBA)
	32	63	125	250	500	1000	2000	4000	8000	
PWL dBA	60.7	79.9	92.0	94.5	99.9	97.1	93.3	88.1	79.0	103.5
PWL dB Lin	100.1	106.1	108.1	103.1	103.1	97.1	92.1	87.1	80.1	

* Includes 5 dB penalty to account for tonality

Table 5-21 Romney transformer octave band calculation details

32	63	125	250	500	1000	2000	4000	8000	Frequency [Hz]
-1	5	7	2	2	-4	-9	-14	-21	Typical Outdoor Transformer Octave band relative distribution [dB Lin]
-39.4	-26.2	-16.1	-8.6	-3.2	0.0	1.2	1.0	-1.1	dB Lin to dBA Conversion Scale
-40.4	-21.2	-9.1	-6.6	-1.2	-4.0	-7.8	-13.0	-22.1	Typical Outdoor Transformer Octave band relative distribution [dBA]
60.7	79.9	92.0	94.5	99.9	97.1	93.3	88.1	79.0	Scaled to 103.5 dBA Transformer
100.1	106.1	108.1	103.1	103.1	97.1	92.1	87.1	80.1	In dB Linear

6 NOISE IMPACT ASSESSMENT

The sound pressure levels at each PoR, Participant, and VLR for the aggregate of all wind turbines and substation associated with the Project, as well as neighbouring projects, were calculated based on the ISO 9613-2 method.

The International Standards Organization (ISO) 9613 standard [15], [16] provides a prediction of the equivalent continuous A-weighted sound pressure level at a distance from one or more point sources under meteorological conditions favorable to propagation from sources of sound emission. These conditions are for downwind propagation or, equivalently, propagation under a well-developed moderate ground-based temperature inversion, commonly occurring at night.

The method consists of octave-band algorithms (i.e., with nominal mid-band frequencies from 31.5 Hz to 8 kHz) for calculating the attenuation of the emitted sound. The algorithm takes into account the following physical effects:

- Geometrical divergence – attenuation due to spherical spreading from the sound source;
- Atmospheric absorption – attenuation due to absorption by the atmosphere; and
- Ground effect – attenuation due to the acoustical properties of the ground.

ISO-9613-2 parameters were set as follows:

- Ambient air temperature: 10°C;
- Ambient barometric pressure: 101.32 kPa;
- Humidity: 70%;
- Global ground factor: 0.7;
- Substation gravel area ground factor: 0;
- The effect of topography was considered.

In accordance with the transition rules for LRP1 projects set forth in the Noise Guidelines, DNV GL has applied a global ground factor of 0.7, with the exception of the gravel pad around the transformer which is set to hard ground.

Additional calculations concerning propagation through foliage were not performed in this NIA, implying that the values calculated for sound attenuation are likely to be conservative in areas where there is foliage present in the line of sight between any turbine and PoR. The estimated accuracy of the ISO 9613 method, as stated in ISO 9613-2, is ± 3 dB.

The wind turbine and transformer noise emission ratings used for each octave band were those specified in Section 5. The noise impact was calculated for each PoR and Participant located within 1,500 m of one or more turbines or 1,000 m from the substation, and the calculated noise level was then compared with the applicable noise limit for each PoR as stated in Table 3-1.

Noise levels were calculated at 4.5 m above ground level for 2-storey PoR/Participants, 7.5 m above ground level for 3-storey PoR/Participants, and at 1.5 m above ground level at 16 points along a 30-m radius circle for each 1-storey PoR/Participant. For the latter, the highest of these 16 values was chosen and presented in the table of noise levels.

6.1 Evaluation of site topography

Section 7.3.1 of ISO 9613-2 [16] states that when calculating the ground attenuation A_{gr} , the General method of calculation is applicable only to ground which is approximately flat, either horizontally or with a constant slope. DNV GL has reviewed the topography at the Romney site to determine if a correction is needed to account for different ground conditions, such as concave terrain.

The Institute of Acoustics (UK) has published a good practice guide (the "Guide") for the assessment of wind turbine noise [17], with Sections 4.3.9 and 4.3.10 of the Guide proposing a 2-step methodology for assessing whether or not a correction to the modelling is needed to account for concave topography. As a first-step, the Guide recommends the use of the criterion shown below to quantitatively evaluate the level of concavity between a turbine and a receptor.

$$h_m \geq 1.5 \cdot Abs(h_s - h_r)/2$$

In this criterion, h_m is the mean height above ground of the direct line of sight from the receiver to the source, as defined in ISO 9613-2. h_s is the height of the source, and h_r is the height of the receiver.

If the criterion is met, then examination of ground profiles between sources and receivers is necessary, as a second-step, to assist with determining the application of a correction factor. The Guide states that the increase in sound level caused by concave terrain can be explained by the reduced ground effect and the potential for additional reflection paths that may exist, as shown in Figure 6-1, taken directly from [17].

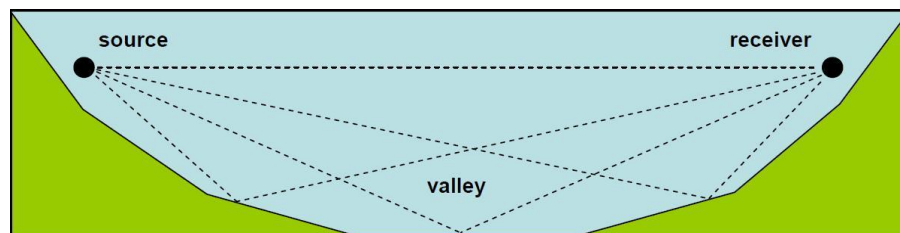

Figure 6-1 Diagram of multiple reflection paths for sound propagation across concave ground

DNV GL has reviewed the topography at the Romney site and evaluated the above criterion for each turbine-receptor pair. It was found that for all turbine to receptor paths, h_m is well below the criterion, indicating that concave paths are not present.

Considering all receptors, the minimum difference between h_m and the criterion is 5.4 m, which occurs between Richardson's T4 with a hub height of 78 m and Receptor R260, which is a 3-storey dwelling. The distance between this pair is 4.8 km. This is the worst-case profile at the site. The topographic profile between Richardson's T4 and R260 is illustrated in Figure 6-3.



Figure 6-2 Topographic profile between Richardson Turbine 4 and Receptor R260

Even in the worst-case profile shown in Figure 6-2, the terrain is relatively flat with a slight upward slope towards the receptor and exhibits minimal to no concavity. The image above has been scaled by a factor of 5 to demonstrate the slight slope. DNV GL does not consider it appropriate to apply any topographical correction at the Romney site.

7 NOISE IMPACT ASSESSMENT RESULTS

The noise level at each PoR within 1,500 m of any turbine or substation of the Project, for wind speeds between 6 m/s and 10 m/s, is tabulated in Table 7-1. For each PoR, the following information is provided:

- The distance to the closest wind turbine or substation;
- For PoR at 1.5 m above ground level, the sound pressure level presented for wind speeds from 6 m/s to 10 m/s is the maximum noise level on the circumference of a 30-m radius circle centered on the PoR;
- For PoR at 4.5 m or 7.5 m above ground level, the sound pressure level presented for wind speeds from 6 m/s to 10 m/s is the noise level at the PoR location at its respective height;
- The sound level limit for that PoR according to the Noise Guidelines at each wind speed from 6 m/s to 10 m/s;
- The applicable background sound level; and
- Whether or not the noise levels at the PoR comply with the Noise Guidelines (for continued reference, compliance is confirmed for all PoR).

The closest distance between a wind turbine and a Receptor for this project is 564 m between Turbine 2 and Receptor 250. The closest distance between a wind turbine and a VLR for this Project is 564 m between Turbine 12 and VLR 5562.

The highest calculated noise level at a Receptor was found at Receptor 248 at 40.0 dBA. The highest calculated noise level at a VLR was found at VLR 5578 at 40.0 dBA. Receptor sound levels are listed in Table 7-1.

In accordance with Section 6.4.5 of the Noise Guidelines, cumulative impact has been assessed at all shared participants and PoRs with neighbouring wind farms at a distance of up to 2 km from a Project turbine. The concordance tables shown in Table 7-3 and Table 7-4 show the breakdown of the noise contribution at shared PoRs and Participants of the Romney Project and adjacent projects.

The results show that the Project complies with the applicable MOECC environmental Noise Guidelines at all wind speeds modelled (i.e., 6, 7, 8, 9 and 10 m/s). Noise iso-contour maps illustrating the maximum noise contribution of the Project are shown in Appendix C.

Table 7-1 Noise impact assessment summary

Point of Reception ID	Receptor height [m]	Distance to nearest source [m]	Nearest source [ID]	Calculated sound pressure level at receptor [dB(A)] at selected wind speed in m/s					Sound level limit [dB(A)] at selected wind speed in m/s					Applicable background sound level	Compliant (Yes/No)
				≤6	7	8	9	10	≤6	7	8	9	10	NPC 232 (C 3)	
R14	4.5	820	T5	36.4	36.4	36.4	36.4	36.4	40	43	45	49	51	40	Yes
R15	4.5	1058	T5	35.6	35.6	35.6	35.6	35.6	40	43	45	49	51	40	Yes
R18	1.5	809	T5	36.5	36.5	36.5	36.5	36.5	40	43	45	49	51	40	Yes
R19	4.5	710	T13	39.7	39.7	39.7	39.7	39.7	40	43	45	49	51	40	Yes
R20	4.5	635	T14	39.9	39.9	39.9	39.9	39.9	40	43	45	49	51	40	Yes
R22	1.5	909	T11	36.0	36.0	36.0	36.0	36.0	40	43	45	49	51	40	Yes
R23	1.5	720	T16	35.3	35.3	35.3	35.3	35.3	40	43	45	49	51	40	Yes
R24	7.5	645	T16	38.1	38.1	38.1	38.1	38.1	40	43	45	49	51	40	Yes
R25	4.5	677	T16	37.3	37.3	37.3	37.3	37.3	40	43	45	49	51	40	Yes
R27	4.5	976	T16	35.9	35.9	35.9	35.9	35.9	40	43	45	49	51	40	Yes
R28	4.5	1345	T8	37.0	37.0	37.0	37.0	37.0	40	43	45	49	51	40	Yes
R34	4.5	669	T3	39.9	39.9	39.9	39.9	39.9	40	43	45	49	51	40	Yes
R37	1.5	984	T2	33.3	33.3	33.3	33.3	33.3	40	43	45	49	51	40	Yes
R145	4.5	1353	T9	31.4	31.4	31.4	31.4	31.4	40	43	45	49	51	40	Yes
R146	4.5	799	T9	36.1	36.1	36.1	36.1	36.1	40	43	45	49	51	40	Yes
R147	4.5	770	T9	36.4	36.4	36.4	36.4	36.4	40	43	45	49	51	40	Yes
R149	1.5	740	T9	35.3	35.3	35.3	35.3	35.3	40	43	45	49	51	40	Yes
R150	1.5	1340	T9	29.7	29.7	29.7	29.7	29.7	40	43	45	49	51	40	Yes
R151	4.5	1438	T9	30.9	30.9	30.9	30.9	30.9	40	43	45	49	51	40	Yes
R152	4.5	1454	T9	30.8	30.8	30.8	30.8	30.8	40	43	45	49	51	40	Yes
R153	4.5	686	T9	37.5	37.5	37.5	37.5	37.5	40	43	45	49	51	40	Yes
R154	4.5	773	T9	36.4	36.4	36.4	36.4	36.4	40	43	45	49	51	40	Yes
R155	4.5	1085	T9	35.5	35.5	35.5	35.5	35.5	40	43	45	49	51	40	Yes
R156	7.5	1153	T5	36.1	36.1	36.1	36.1	36.1	40	43	45	49	51	40	Yes
R157	4.5	726	T5	37.2	37.2	37.2	37.2	37.2	40	43	45	49	51	40	Yes
R158	4.5	630	T5	38.4	38.4	38.4	38.4	38.4	40	43	45	49	51	40	Yes
R159	4.5	567	T5	39.4	39.4	39.4	39.4	39.4	40	43	45	49	51	40	Yes
R160	4.5	724	T5	39.1	39.1	39.1	39.1	39.1	40	43	45	49	51	40	Yes
R161	4.5	823	T5	38.0	38.0	38.0	38.0	38.0	40	43	45	49	51	40	Yes
R162	4.5	758	T6	38.4	38.4	38.4	38.4	38.4	40	43	45	49	51	40	Yes
R163	4.5	666	T6	38.9	38.9	38.9	38.9	38.9	40	43	45	49	51	40	Yes
R164	4.5	814	T11	38.9	38.9	38.9	38.9	38.9	40	43	45	49	51	40	Yes
R166	4.5	761	T5	38.3	38.3	38.3	38.3	38.3	40	43	45	49	51	40	Yes
R167	4.5	779	T10	38.2	38.2	38.2	38.2	38.2	40	43	45	49	51	40	Yes
R169	4.5	662	T10	39.0	39.0	39.0	39.0	39.0	40	43	45	49	51	40	Yes

Point of Reception ID	Receptor height [m]	Distance to nearest source [m]	Nearest source [ID]	Calculated sound pressure level at receptor [dB(A)] at selected wind speed in m/s					Sound level limit [dB(A)] at selected wind speed in m/s					Applicable background sound level NPC 232 (C 3)	Compliant (Yes/No)
				≤6	7	8	9	10	≤6	7	8	9	10		
R170	4.5	778	T14	38.6	38.6	38.6	38.6	38.6	40	43	45	49	51	40	Yes
R171	7.5	667	T14	39.1	39.1	39.1	39.1	39.1	40	43	45	49	51	40	Yes
R172	1.5	849	T14	36.1	36.1	36.1	36.1	36.1	40	43	45	49	51	40	Yes
R174	1.5	590	T15	37.7	37.7	37.7	37.7	37.7	40	43	45	49	51	40	Yes
R175	4.5	772	T13	38.2	38.2	38.2	38.2	38.2	40	43	45	49	51	40	Yes
R176	4.5	913	T15	36.8	36.8	36.8	36.8	36.8	40	43	45	49	51	40	Yes
R177	4.5	791	T12	39.6	39.6	39.6	39.6	39.6	40	43	45	49	51	40	Yes
R178	1.5	748	T12	37.9	37.9	37.9	37.9	37.9	40	43	45	49	51	40	Yes
R179	1.5	765	T10	37.6	37.6	37.6	37.6	37.6	40	43	45	49	51	40	Yes
R180	1.5	745	T10	37.7	37.7	37.7	37.7	37.7	40	43	45	49	51	40	Yes
R182	4.5	835	T12	39.0	39.0	39.0	39.0	39.0	40	43	45	49	51	40	Yes
R183	1.5	731	T9	37.4	37.4	37.4	37.4	37.4	40	43	45	49	51	40	Yes
R184	4.5	786	T9	37.6	37.6	37.6	37.6	37.6	40	43	45	49	51	40	Yes
R185	1.5	832	T9	36.6	36.6	36.6	36.6	36.6	40	43	45	49	51	40	Yes
R186	4.5	799	T9	37.3	37.3	37.3	37.3	37.3	40	43	45	49	51	40	Yes
R189	1.5	617	T12	37.8	37.8	37.8	37.8	37.8	40	43	45	49	51	40	Yes
R190	1.5	766	T12	37.0	37.0	37.0	37.0	37.0	40	43	45	49	51	40	Yes
R191	1.5	751	T13	37.0	37.0	37.0	37.0	37.0	40	43	45	49	51	40	Yes
R192	1.5	742	T13	36.8	36.8	36.8	36.8	36.8	40	43	45	49	51	40	Yes
R194	4.5	786	T13	37.5	37.5	37.5	37.5	37.5	40	43	45	49	51	40	Yes
R195	4.5	763	T13	37.5	37.5	37.5	37.5	37.5	40	43	45	49	51	40	Yes
R196	1.5	1228	T13	32.4	32.4	32.4	32.4	32.4	40	43	45	49	51	40	Yes
R197	4.5	811	T14	36.9	36.9	36.9	36.9	36.9	40	43	45	49	51	40	Yes
R198	1.5	817	T14	34.9	34.9	34.9	34.9	34.9	40	43	45	49	51	40	Yes
R199	4.5	742	T14	37.3	37.3	37.3	37.3	37.3	40	43	45	49	51	40	Yes
R200	4.5	958	T14	35.5	35.5	35.5	35.5	35.5	40	43	45	49	51	40	Yes
R201	4.5	1021	T15	35.6	35.6	35.6	35.6	35.6	40	43	45	49	51	40	Yes
R202	4.5	754	T15	37.3	37.3	37.3	37.3	37.3	40	43	45	49	51	40	Yes
R203	4.5	1063	T15	34.7	34.7	34.7	34.7	34.7	40	43	45	49	51	40	Yes
R204	1.5	1039	T15	32.9	32.9	32.9	32.9	32.9	40	43	45	49	51	40	Yes
R205	1.5	1449	T15	30.8	30.8	30.8	30.8	30.8	40	43	45	49	51	40	Yes
R206	1.5	1458	T15	30.8	30.8	30.8	30.8	30.8	40	43	45	49	51	40	Yes
R207	4.5	1335	T16	33.1	33.1	33.1	33.1	33.1	40	43	45	49	51	40	Yes
R208	1.5	898	T16	33.5	33.5	33.5	33.5	33.5	40	43	45	49	51	40	Yes
R209	1.5	992	T16	32.5	32.5	32.5	32.5	32.5	40	43	45	49	51	40	Yes
R210	4.5	1181	T16	33.7	33.7	33.7	33.7	33.7	40	43	45	49	51	40	Yes
R211	4.5	1273	T16	33.4	33.4	33.4	33.4	33.4	40	43	45	49	51	40	Yes

Point of Reception ID	Receptor height [m]	Distance to nearest source [m]	Nearest source [ID]	Calculated sound pressure level at receptor [dB(A)] at selected wind speed in m/s					Sound level limit [dB(A)] at selected wind speed in m/s					Applicable background sound level NPC 232 (C 3)	Compliant (Yes/No)
				≤6	7	8	9	10	≤6	7	8	9	10		
R212	1.5	1500	T16	29.8	29.8	29.8	29.8	29.8	40	43	45	49	51	40	Yes
R217	1.5	1347	T16	36.1	36.1	36.1	36.1	36.1	40	43	45	49	51	40	Yes
R218	1.5	1350	T16	33.3	33.3	33.3	33.3	33.3	40	43	45	49	51	40	Yes
R219	1.5	1382	T16	33.2	33.2	33.2	33.2	33.2	40	43	45	49	51	40	Yes
R220	1.5	1398	T16	33.3	33.3	33.3	33.3	33.3	40	43	45	49	51	40	Yes
R222	4.5	1183	T15	35.6	35.6	35.6	35.6	35.6	40	43	45	49	51	40	Yes
R225	1.5	1214	T8	34.8	34.8	34.8	34.8	34.8	40	43	45	49	51	40	Yes
R230	4.5	1430	T1	39.3	39.3	39.3	39.3	39.3	40	43	45	49	51	40	Yes
R233	1.5	1357	A1	36.7	36.7	36.7	36.7	36.7	40	43	45	49	51	40	Yes
R234	4.5	1288	A1	38.2	38.2	38.2	38.2	38.2	40	43	45	49	51	40	Yes
R243	4.5	1341	T8	38.3	38.3	38.3	38.3	38.3	40	43	45	49	51	40	Yes
R244	1.5	1082	T8	35.1	35.1	35.1	35.1	35.1	40	43	45	49	51	40	Yes
R246	4.5	782	T8	37.9	37.9	37.9	37.9	37.9	40	43	45	49	51	40	Yes
R247	4.5	654	T11	39.8	39.8	39.8	39.8	39.8	40	43	45	49	51	40	Yes
R248	4.5	802	T7	39.9	39.9	39.9	39.9	39.9	40	43	45	49	51	40	Yes
R249	4.5	824	T2	39.8	39.8	39.8	39.8	39.8	40	43	45	49	51	40	Yes
R250	1.5	564	T2	38.2	38.2	38.2	38.2	38.2	40	43	45	49	51	40	Yes
R251	1.5	660	T2	36.7	36.7	36.7	36.7	36.7	40	43	45	49	51	40	Yes
R252	1.5	632	T3	37.8	37.8	37.8	37.8	37.8	40	43	45	49	51	40	Yes
R253	4.5	755	T1	39.5	39.5	39.5	39.5	39.5	40	43	45	49	51	40	Yes
R254	1.5	854	T4	36.8	36.8	36.8	36.8	36.8	40	43	45	49	51	40	Yes
R255	4.5	1045	T1	37.8	37.8	37.8	37.8	37.8	40	43	45	49	51	40	Yes
R256	4.5	1032	A1	37.3	37.3	37.3	37.3	37.3	40	43	45	49	51	40	Yes
V257	4.5	607	T1	40.0	40.0	40.0	40.0	40.0	40	43	45	49	51	40	Yes
R258	4.5	694	A1	38.8	38.8	38.8	38.8	38.8	40	43	45	49	51	40	Yes
R260	7.5	1119	A1	35.8	35.8	35.8	35.8	35.8	40	43	45	49	51	40	Yes
R261	4.5	1357	A1	34.6	34.6	34.6	34.6	34.6	40	43	45	49	51	40	Yes
R262	4.5	1431	A1	34.8	34.8	34.8	34.8	34.8	40	43	45	49	51	40	Yes
R265	4.5	1212	A1	34.6	34.6	34.6	34.6	34.6	40	43	45	49	51	40	Yes
R266	4.5	1144	A1	34.8	34.8	34.8	34.8	34.8	40	43	45	49	51	40	Yes
R267	1.5	1173	A1	32.5	32.5	32.5	32.5	32.5	40	43	45	49	51	40	Yes
R268	4.5	1290	A1	33.8	33.8	33.8	33.8	33.8	40	43	45	49	51	40	Yes
R271	4.5	972	T1	36.1	36.1	36.1	36.1	36.1	40	43	45	49	51	40	Yes
R275	4.5	1476	T17	31.6	31.6	31.6	31.6	31.6	40	43	45	49	51	40	Yes
R276	4.5	1318	T3	35.2	35.2	35.2	35.2	35.2	40	43	45	49	51	40	Yes
R277	4.5	1259	T2	34.9	34.9	34.9	34.9	34.9	40	43	45	49	51	40	Yes
R320	1.5	1342	T17	30.1	30.1	30.1	30.1	30.1	40	43	45	49	51	40	Yes

Point of Reception ID	Receptor height [m]	Distance to nearest source [m]	Nearest source [ID]	Calculated sound pressure level at receptor [dB(A)] at selected wind speed in m/s					Sound level limit [dB(A)] at selected wind speed in m/s					Applicable background sound level NPC 232 (C 3)	Compliant (Yes/No)
				≤6	7	8	9	10	≤6	7	8	9	10		
R321	4.5	843	T17	35.2	35.2	35.2	35.2	35.2	40	43	45	49	51	40	Yes
R322	4.5	651	T17	37.4	37.4	37.4	37.4	37.4	40	43	45	49	51	40	Yes
R323	1.5	734	T17	34.8	34.8	34.8	34.8	34.8	40	43	45	49	51	40	Yes
R324	4.5	920	T17	34.5	34.5	34.5	34.5	34.5	40	43	45	49	51	40	Yes
R325	4.5	1399	T17	32.7	32.7	32.7	32.7	32.7	40	43	45	49	51	40	Yes
R327	4.5	1484	T17	35.3	35.3	35.3	35.3	35.3	40	43	45	49	51	40	Yes
R328	4.5	878	T17	36.0	36.0	36.0	36.0	36.0	40	43	45	49	51	40	Yes
R329	1.5	1030	T17	32.7	32.7	32.7	32.7	32.7	40	43	45	49	51	40	Yes
R330	4.5	1187	T17	34.0	34.0	34.0	34.0	34.0	40	43	45	49	51	40	Yes
R442	4.5	1100	A1	34.7	34.7	34.7	34.7	34.7	40	43	45	49	51	40	Yes
R443	4.5	1212	T1	35.1	35.1	35.1	35.1	35.1	40	43	45	49	51	40	Yes
R449	4.5	1029	T17	35.6	35.6	35.6	35.6	35.6	40	43	45	49	51	40	Yes
R450	1.5	892	T17	34.3	34.3	34.3	34.3	34.3	40	43	45	49	51	40	Yes
R494	4.5	809	TRANS	39.4	39.4	39.4	39.4	39.4	40	43	45	49	51	40	Yes
R495	1.5	741	TRANS	38.0	38.0	38.0	38.0	38.0	40	43	45	49	51	40	Yes
R497	4.5	817	TRANS	39.6	39.6	39.6	39.6	39.6	40	43	45	49	51	40	Yes
R560	4.5	1445	T12	31.1	31.1	31.1	31.1	31.1	40	43	45	49	51	40	Yes
R561	4.5	1369	T12	31.6	31.6	31.6	31.6	31.6	40	43	45	49	51	40	Yes
R562	1.5	1344	T12	29.8	29.8	29.8	29.8	29.8	40	43	45	49	51	40	Yes
R563	4.5	1321	T12	31.8	31.8	31.8	31.8	31.8	40	43	45	49	51	40	Yes
R565	1.5	1194	T9	30.7	30.7	30.7	30.7	30.7	40	43	45	49	51	40	Yes
R569	1.5	1160	T9	31.1	31.1	31.1	31.1	31.1	40	43	45	49	51	40	Yes
R581	4.5	1185	A1	34.3	34.3	34.3	34.3	34.3	40	43	45	49	51	40	Yes
R624	1.5	1374	T9	29.9	29.9	29.9	29.9	29.9	40	43	45	49	51	40	Yes
R625	1.5	1456	T9	29.4	29.4	29.4	29.4	29.4	40	43	45	49	51	40	Yes
R628	1.5	1000	T9	33.3	33.3	33.3	33.3	33.3	40	43	45	49	51	40	Yes
R629	4.5	1166	T12	32.9	32.9	32.9	32.9	32.9	40	43	45	49	51	40	Yes
R630	4.5	748	T12	36.7	36.7	36.7	36.7	36.7	40	43	45	49	51	40	Yes
R634	4.5	1116	T12	33.3	33.3	33.3	33.3	33.3	40	43	45	49	51	40	Yes
R635	1.5	989	T12	32.5	32.5	32.5	32.5	32.5	40	43	45	49	51	40	Yes
R636	1.5	979	T12	32.6	32.6	32.6	32.6	32.6	40	43	45	49	51	40	Yes
R637	1.5	932	T12	33.1	33.1	33.1	33.1	33.1	40	43	45	49	51	40	Yes
R638	1.5	954	T12	32.9	32.9	32.9	32.9	32.9	40	43	45	49	51	40	Yes
R639	1.5	930	T12	33.1	33.1	33.1	33.1	33.1	40	43	45	49	51	40	Yes
R640	4.5	900	T12	35.1	35.1	35.1	35.1	35.1	40	43	45	49	51	40	Yes
R641	1.5	908	T12	33.3	33.3	33.3	33.3	33.3	40	43	45	49	51	40	Yes
R643	1.5	889	T12	33.5	33.5	33.5	33.5	33.5	40	43	45	49	51	40	Yes

Point of Reception ID	Receptor height [m]	Distance to nearest source [m]	Nearest source [ID]	Calculated sound pressure level at receptor [dB(A)] at selected wind speed in m/s					Sound level limit [dB(A)] at selected wind speed in m/s					Applicable background sound level NPC 232 (C 3)	Compliant (Yes/No)
				≤6	7	8	9	10	≤6	7	8	9	10		
R645	1.5	862	T12	33.8	33.8	33.8	33.8	33.8	40	43	45	49	51	40	Yes
R647	1.5	838	T12	34.1	34.1	34.1	34.1	34.1	40	43	45	49	51	40	Yes
R650	1.5	813	T12	34.4	34.4	34.4	34.4	34.4	40	43	45	49	51	40	Yes
R652	1.5	792	T12	34.6	34.6	34.6	34.6	34.6	40	43	45	49	51	40	Yes
R660	1.5	709	T12	35.8	35.8	35.8	35.8	35.8	40	43	45	49	51	40	Yes
R665	4.5	629	T12	38.3	38.3	38.3	38.3	38.3	40	43	45	49	51	40	Yes
R669	4.5	1270	T9	32.8	32.8	32.8	32.8	32.8	40	43	45	49	51	40	Yes
R671	4.5	1420	T9	31.2	31.2	31.2	31.2	31.2	40	43	45	49	51	40	Yes
R672	1.5	1400	T9	29.4	29.4	29.4	29.4	29.4	40	43	45	49	51	40	Yes
R675	1.5	1375	T9	29.6	29.6	29.6	29.6	29.6	40	43	45	49	51	40	Yes
R676	4.5	1357	T9	31.5	31.5	31.5	31.5	31.5	40	43	45	49	51	40	Yes
R677	1.5	1336	T9	29.8	29.8	29.8	29.8	29.8	40	43	45	49	51	40	Yes
R678	4.5	1323	T9	31.8	31.8	31.8	31.8	31.8	40	43	45	49	51	40	Yes
R680	1.5	1293	T9	30.1	30.1	30.1	30.1	30.1	40	43	45	49	51	40	Yes
R681	1.5	1050	T9	33.0	33.0	33.0	33.0	33.0	40	43	45	49	51	40	Yes
R685	1.5	1251	T9	30.4	30.4	30.4	30.4	30.4	40	43	45	49	51	40	Yes
R686	4.5	1231	T9	32.4	32.4	32.4	32.4	32.4	40	43	45	49	51	40	Yes
R687	1.5	1202	T9	30.7	30.7	30.7	30.7	30.7	40	43	45	49	51	40	Yes
R688	1.5	1183	T9	30.9	30.9	30.9	30.9	30.9	40	43	45	49	51	40	Yes
R689	4.5	1135	T9	33.1	33.1	33.1	33.1	33.1	40	43	45	49	51	40	Yes
R690	4.5	1118	T9	33.2	33.2	33.2	33.2	33.2	40	43	45	49	51	40	Yes
R691	1.5	1101	T9	31.5	31.5	31.5	31.5	31.5	40	43	45	49	51	40	Yes
R701	1.5	689	T13	37.9	37.9	37.9	37.9	37.9	40	43	45	49	51	40	Yes
R704	1.5	582	T9	38.2	38.2	38.2	38.2	38.2	40	43	45	49	51	40	Yes
R720	1.5	611	T17	36.7	36.7	36.7	36.7	36.7	40	43	45	49	51	40	Yes
R818	4.5	792	T16	37.1	37.1	37.1	37.1	37.1	40	43	45	49	51	40	Yes
R819	1.5	668	A1	36.5	36.5	36.5	36.5	36.5	40	43	45	49	51	40	Yes
R821	1.5	814	T16	35.2	35.2	35.2	35.2	35.2	40	43	45	49	51	40	Yes
R823	1.5	1050	T16	32.0	32.0	32.0	32.0	32.0	40	43	45	49	51	40	Yes
R825	1.5	1449	T16	29.5	29.5	29.5	29.5	29.5	40	43	45	49	51	40	Yes
R910	4.5	1026	T14	35.0	35.0	35.0	35.0	35.0	40	43	45	49	51	40	Yes
R996	4.5	816	TRANS	38.9	38.9	38.9	38.9	38.9	40	43	45	49	51	40	Yes
R997	1.5	660	TRANS	36.2	36.2	36.2	36.2	36.2	40	43	45	49	51	40	Yes
R2034	4.5	849	TRANS	39.7	39.7	39.7	39.7	39.7	40	43	45	49	51	40	Yes
R2035	1.5	800	TRANS	38.8	38.8	38.8	38.8	38.8	40	43	45	49	51	40	Yes
R2036	1.5	802	TRANS	37.1	37.1	37.1	37.1	37.1	40	43	45	49	51	40	Yes
R2037	4.5	729	TRANS	38.8	38.8	38.8	38.8	38.8	40	43	45	49	51	40	Yes

Point of Reception ID	Receptor height [m]	Distance to nearest source [m]	Nearest source [ID]	Calculated sound pressure level at receptor [dB(A)] at selected wind speed in m/s					Sound level limit [dB(A)] at selected wind speed in m/s					Applicable background sound level NPC 232 (C 3)	Compliant (Yes/No)
				≤6	7	8	9	10	≤6	7	8	9	10		
R2038	4.5	713	TRANS	38.7	38.7	38.7	38.7	38.7	40	43	45	49	51	40	Yes
R2039	1.5	629	TRANS	37.4	37.4	37.4	37.4	37.4	40	43	45	49	51	40	Yes
R2072	4.5	1148	A1	34.8	34.8	34.8	34.8	34.8	40	43	45	49	51	40	Yes
R2074	4.5	1421	T5	32.3	32.3	32.3	32.3	32.3	40	43	45	49	51	40	Yes
R2082	4.5	803	T9	36.0	36.0	36.0	36.0	36.0	40	43	45	49	51	40	Yes
R2085	4.5	776	T12	39.6	39.6	39.6	39.6	39.6	40	43	45	49	51	40	Yes
R2086	1.5	837	T12	37.1	37.1	37.1	37.1	37.1	40	43	45	49	51	40	Yes
R2087	4.5	849	T9	38.4	38.4	38.4	38.4	38.4	40	43	45	49	51	40	Yes
R2088	1.5	1357	T9	30.2	30.2	30.2	30.2	30.2	40	43	45	49	51	40	Yes
R2089	1.5	1400	T9	29.7	29.7	29.7	29.7	29.7	40	43	45	49	51	40	Yes
R2091	1.5	1386	T9	29.4	29.4	29.4	29.4	29.4	40	43	45	49	51	40	Yes
R2092	4.5	1084	T9	33.4	33.4	33.4	33.4	33.4	40	43	45	49	51	40	Yes
R2093	4.5	650	T10	39.0	39.0	39.0	39.0	39.0	40	43	45	49	51	40	Yes
R2094	4.5	673	T10	38.6	38.6	38.6	38.6	38.6	40	43	45	49	51	40	Yes
R2095	4.5	822	T2	39.2	39.2	39.2	39.2	39.2	40	43	45	49	51	40	Yes
R2096	1.5	660	T5	37.5	37.5	37.5	37.5	37.5	40	43	45	49	51	40	Yes
R2097	1.5	713	T3	37.8	37.8	37.8	37.8	37.8	40	43	45	49	51	40	Yes
R2099	1.5	810	T3	36.4	36.4	36.4	36.4	36.4	40	43	45	49	51	40	Yes
R2143	1.5	1293	T12	30.1	30.1	30.1	30.1	30.1	40	43	45	49	51	40	Yes
R2144	1.5	779	T12	34.8	34.8	34.8	34.8	34.8	40	43	45	49	51	40	Yes
R2145	4.5	770	T12	37.6	37.6	37.6	37.6	37.6	40	43	45	49	51	40	Yes
R2146	1.5	965	T12	34.0	34.0	34.0	34.0	34.0	40	43	45	49	51	40	Yes
R2152	4.5	1416	T16	31.6	31.6	31.6	31.6	31.6	40	43	45	49	51	40	Yes
R2153	1.5	1384	T16	29.7	29.7	29.7	29.7	29.7	40	43	45	49	51	40	Yes
R2154	1.5	1362	T16	29.8	29.8	29.8	29.8	29.8	40	43	45	49	51	40	Yes
V5002	4.5	754	T9	36.6	36.6	36.6	36.6	36.6	40	43	45	49	51	40	Yes
V5009	4.5	952	T2	35.9	35.9	35.9	35.9	35.9	40	43	45	49	51	40	Yes
R5016	1.5	632	T14	38.3	38.3	38.3	38.3	38.3	40	43	45	49	51	40	Yes
R5017	4.5	631	T1	39.5	39.5	39.5	39.5	39.5	40	43	45	49	51	40	Yes
V5019	4.5	778	T2	39.0	39.0	39.0	39.0	39.0	40	43	45	49	51	40	Yes
V5021	4.5	1187	T15	35.7	35.7	35.7	35.7	35.7	40	43	45	49	51	40	Yes
V5023	4.5	831	T14	38.5	38.5	38.5	38.5	38.5	40	43	45	49	51	40	Yes
V5024	4.5	964	T15	35.2	35.2	35.2	35.2	35.2	40	43	45	49	51	40	Yes
V5025	4.5	986	T13	36.6	36.6	36.6	36.6	36.6	40	43	45	49	51	40	Yes
R5026	4.5	911	T15	35.8	35.8	35.8	35.8	35.8	40	43	45	49	51	40	Yes
V5028	4.5	725	T13	37.9	37.9	37.9	37.9	37.9	40	43	45	49	51	40	Yes
V5029	4.5	702	T16	36.9	36.9	36.9	36.9	36.9	40	43	45	49	51	40	Yes

Point of Reception ID	Receptor height [m]	Distance to nearest source [m]	Nearest source [ID]	Calculated sound pressure level at receptor [dB(A)] at selected wind speed in m/s					Sound level limit [dB(A)] at selected wind speed in m/s					Applicable background sound level NPC 232 (C 3)	Compliant (Yes/No)
				≤6	7	8	9	10	≤6	7	8	9	10		
V5030	4.5	689	T5	37.8	37.8	37.8	37.8	37.8	40	43	45	49	51	40	Yes
V5102	4.5	863	T9	36.3	36.3	36.3	36.3	36.3	40	43	45	49	51	40	Yes
V5171	4.5	1482	T16	32.9	32.9	32.9	32.9	32.9	40	43	45	49	51	40	Yes
V5172	4.5	1491	T16	32.1	32.1	32.1	32.1	32.1	40	43	45	49	51	40	Yes
V5174	4.5	1496	T16	31.9	31.9	31.9	31.9	31.9	40	43	45	49	51	40	Yes
V5175	4.5	1483	T16	31.9	31.9	31.9	31.9	31.9	40	43	45	49	51	40	Yes
V5177	4.5	1048	T16	34.3	34.3	34.3	34.3	34.3	40	43	45	49	51	40	Yes
R5184	4.5	1281	T16	32.2	32.2	32.2	32.2	32.2	40	43	45	49	51	40	Yes
R5185	4.5	1260	T16	32.3	32.3	32.3	32.3	32.3	40	43	45	49	51	40	Yes
V5190	4.5	1397	T12	31.6	31.6	31.6	31.6	31.6	40	43	45	49	51	40	Yes
V5193	4.5	1498	T12	30.8	30.8	30.8	30.8	30.8	40	43	45	49	51	40	Yes
R5199	4.5	1305	T16	32.1	32.1	32.1	32.1	32.1	40	43	45	49	51	40	Yes
R5200	4.5	1345	T16	31.8	31.8	31.8	31.8	31.8	40	43	45	49	51	40	Yes
V5201	4.5	1447	T16	31.5	31.5	31.5	31.5	31.5	40	43	45	49	51	40	Yes
R5202	4.5	1364	T16	31.8	31.8	31.8	31.8	31.8	40	43	45	49	51	40	Yes
V5203	4.5	1491	T16	31.3	31.3	31.3	31.3	31.3	40	43	45	49	51	40	Yes
V5244	4.5	1199	T5	35.1	35.1	35.1	35.1	35.1	40	43	45	49	51	40	Yes
V5245	4.5	1174	T9	35.2	35.2	35.2	35.2	35.2	40	43	45	49	51	40	Yes
V5246	4.5	1145	T9	32.9	32.9	32.9	32.9	32.9	40	43	45	49	51	40	Yes
V5247	4.5	886	T9	36.3	36.3	36.3	36.3	36.3	40	43	45	49	51	40	Yes
V5248	4.5	728	T9	37.3	37.3	37.3	37.3	37.3	40	43	45	49	51	40	Yes
V5262	4.5	429	TRANS	39.7	39.7	39.7	39.7	39.7	40	43	45	49	51	40	Yes
V5276	4.5	875	T1	37.7	37.7	37.7	37.7	37.7	40	43	45	49	51	40	Yes
V5277	4.5	604	A1	38.8	38.8	38.8	38.8	38.8	40	43	45	49	51	40	Yes
V5288	4.5	1123	T9	33.1	33.1	33.1	33.1	33.1	40	43	45	49	51	40	Yes
V5289	4.5	793	T17	36.8	36.8	36.8	36.8	36.8	40	43	45	49	51	40	Yes
V5290	4.5	1003	T17	35.6	35.6	35.6	35.6	35.6	40	43	45	49	51	40	Yes
V5298	4.5	964	T17	34.1	34.1	34.1	34.1	34.1	40	43	45	49	51	40	Yes
V5317	4.5	1391	T17	31.7	31.7	31.7	31.7	31.7	40	43	45	49	51	40	Yes
V5318	4.5	747	T17	36.1	36.1	36.1	36.1	36.1	40	43	45	49	51	40	Yes
V5321	4.5	1444	T17	32.1	32.1	32.1	32.1	32.1	40	43	45	49	51	40	Yes
V5328	4.5	1389	T1	34.8	34.8	34.8	34.8	34.8	40	43	45	49	51	40	Yes
V5339	4.5	750	T2	37.2	37.2	37.2	37.2	37.2	40	43	45	49	51	40	Yes
V5340	4.5	860	T2	36.4	36.4	36.4	36.4	36.4	40	43	45	49	51	40	Yes
V5348	4.5	833	T17	36.5	36.5	36.5	36.5	36.5	40	43	45	49	51	40	Yes
V5350	4.5	875	T17	36.3	36.3	36.3	36.3	36.3	40	43	45	49	51	40	Yes
V5351	4.5	904	T17	35.8	35.8	35.8	35.8	35.8	40	43	45	49	51	40	Yes

Point of Reception ID	Receptor height [m]	Distance to nearest source [m]	Nearest source [ID]	Calculated sound pressure level at receptor [dB(A)] at selected wind speed in m/s					Sound level limit [dB(A)] at selected wind speed in m/s					Applicable background sound level NPC 232 (C 3)	Compliant (Yes/No)
				≤6	7	8	9	10	≤6	7	8	9	10		
V5352	4.5	1138	T17	34.0	34.0	34.0	34.0	34.0	40	43	45	49	51	40	Yes
V5353	4.5	1031	T17	33.6	33.6	33.6	33.6	33.6	40	43	45	49	51	40	Yes
V5354	4.5	1385	T17	31.8	31.8	31.8	31.8	31.8	40	43	45	49	51	40	Yes
V5357	4.5	1375	T17	33.1	33.1	33.1	33.1	33.1	40	43	45	49	51	40	Yes
V5396	4.5	1376	T2	34.8	34.8	34.8	34.8	34.8	40	43	45	49	51	40	Yes
V5397	4.5	877	T2	36.2	36.2	36.2	36.2	36.2	40	43	45	49	51	40	Yes
V5399	4.5	736	T5	37.1	37.1	37.1	37.1	37.1	40	43	45	49	51	40	Yes
V5402	4.5	1275	T17	33.6	33.6	33.6	33.6	33.6	40	43	45	49	51	40	Yes
V5403	4.5	1011	T17	35.0	35.0	35.0	35.0	35.0	40	43	45	49	51	40	Yes
V5418	4.5	1170	A1	35.2	35.2	35.2	35.2	35.2	40	43	45	49	51	40	Yes
V5420	4.5	1246	A1	34.7	34.7	34.7	34.7	34.7	40	43	45	49	51	40	Yes
V5442	4.5	1297	A1	34.5	34.5	34.5	34.5	34.5	40	43	45	49	51	40	Yes
V5444	4.5	1099	A1	34.6	34.6	34.6	34.6	34.6	40	43	45	49	51	40	Yes
V5463	4.5	976	T6	37.4	37.4	37.4	37.4	37.4	40	43	45	49	51	40	Yes
V5466	4.5	683	T9	38.1	38.1	38.1	38.1	38.1	40	43	45	49	51	40	Yes
V5467	4.5	1199	T9	32.7	32.7	32.7	32.7	32.7	40	43	45	49	51	40	Yes
V5468	4.5	960	T15	36.3	36.3	36.3	36.3	36.3	40	43	45	49	51	40	Yes
V5470	4.5	751	T10	39.5	39.5	39.5	39.5	39.5	40	43	45	49	51	40	Yes
V5471	4.5	881	T5	37.5	37.5	37.5	37.5	37.5	40	43	45	49	51	40	Yes
V5473	4.5	810	T1	37.2	37.2	37.2	37.2	37.2	40	43	45	49	51	40	Yes
V5475	4.5	940	T13	37.7	37.7	37.7	37.7	37.7	40	43	45	49	51	40	Yes
V5476	4.5	766	T9	39.4	39.4	39.4	39.4	39.4	40	43	45	49	51	40	Yes
V5477	4.5	582	T10	39.9	39.9	39.9	39.9	39.9	40	43	45	49	51	40	Yes
V5478	4.5	847	T5	37.8	37.8	37.8	37.8	37.8	40	43	45	49	51	40	Yes
V5479	4.5	789	T13	39.3	39.3	39.3	39.3	39.3	40	43	45	49	51	40	Yes
V5480	4.5	728	T13	38.7	38.7	38.7	38.7	38.7	40	43	45	49	51	40	Yes
V5482	4.5	667	T6	38.9	38.9	38.9	38.9	38.9	40	43	45	49	51	40	Yes
V5484	4.5	567	T14	39.8	39.8	39.8	39.8	39.8	40	43	45	49	51	40	Yes
V5485	4.5	684	T14	38.6	38.6	38.6	38.6	38.6	40	43	45	49	51	40	Yes
V5486	4.5	742	T6	38.7	38.7	38.7	38.7	38.7	40	43	45	49	51	40	Yes
V5488	4.5	764	T15	36.7	36.7	36.7	36.7	36.7	40	43	45	49	51	40	Yes
V5489	4.5	891	T6	37.6	37.6	37.6	37.6	37.6	40	43	45	49	51	40	Yes
V5490	4.5	815	T14	36.9	36.9	36.9	36.9	36.9	40	43	45	49	51	40	Yes
V5496	4.5	637	A1	38.5	38.5	38.5	38.5	38.5	40	43	45	49	51	40	Yes
V5498	4.5	605	T5	38.7	38.7	38.7	38.7	38.7	40	43	45	49	51	40	Yes
V5499	4.5	1163	T16	35.5	35.5	35.5	35.5	35.5	40	43	45	49	51	40	Yes
V5500	4.5	792	T16	37.2	37.2	37.2	37.2	37.2	40	43	45	49	51	40	Yes

Point of Reception ID	Receptor height [m]	Distance to nearest source [m]	Nearest source [ID]	Calculated sound pressure level at receptor [dB(A)] at selected wind speed in m/s					Sound level limit [dB(A)] at selected wind speed in m/s					Applicable background sound level	Compliant (Yes/No)
				≤6	7	8	9	10	≤6	7	8	9	10	NPC 232 (C 3)	
V5503	4.5	1289	T14	36.1	36.1	36.1	36.1	36.1	40	43	45	49	51	40	Yes
V5504	4.5	900	T14	37.6	37.6	37.6	37.6	37.6	40	43	45	49	51	40	Yes
V5506	4.5	809	T14	38.2	38.2	38.2	38.2	38.2	40	43	45	49	51	40	Yes
V5507	4.5	697	T3	38.6	38.6	38.6	38.6	38.6	40	43	45	49	51	40	Yes
V5508	4.5	683	T5	39.9	39.9	39.9	39.9	39.9	40	43	45	49	51	40	Yes
V5509	4.5	762	T4	39.4	39.4	39.4	39.4	39.4	40	43	45	49	51	40	Yes
V5510	4.5	579	T14	39.6	39.6	39.6	39.6	39.6	40	43	45	49	51	40	Yes
V5511	4.5	707	T14	38.4	38.4	38.4	38.4	38.4	40	43	45	49	51	40	Yes
V5513	4.5	739	T13	38.4	38.4	38.4	38.4	38.4	40	43	45	49	51	40	Yes
V5514	4.5	594	T15	39.4	39.4	39.4	39.4	39.4	40	43	45	49	51	40	Yes
V5515	4.5	682	T15	38.8	38.8	38.8	38.8	38.8	40	43	45	49	51	40	Yes
V5516	4.5	625	T11	39.4	39.4	39.4	39.4	39.4	40	43	45	49	51	40	Yes
V5517	4.5	704	T15	38.9	38.9	38.9	38.9	38.9	40	43	45	49	51	40	Yes
V5518	4.5	759	T11	38.8	38.8	38.8	38.8	38.8	40	43	45	49	51	40	Yes
V5519	4.5	649	T11	39.4	39.4	39.4	39.4	39.4	40	43	45	49	51	40	Yes
V5520	4.5	1110	T15	35.9	35.9	35.9	35.9	35.9	40	43	45	49	51	40	Yes
V5521	4.5	984	T15	36.5	36.5	36.5	36.5	36.5	40	43	45	49	51	40	Yes
V5522	4.5	639	T2	38.5	38.5	38.5	38.5	38.5	40	43	45	49	51	40	Yes
V5523	4.5	742	T15	38.6	38.6	38.6	38.6	38.6	40	43	45	49	51	40	Yes
V5525	4.5	1114	A1	37.2	37.2	37.2	37.2	37.2	40	43	45	49	51	40	Yes
V5526	4.5	1072	A1	35.6	35.6	35.6	35.6	35.6	40	43	45	49	51	40	Yes
V5527	4.5	1046	A1	35.7	35.7	35.7	35.7	35.7	40	43	45	49	51	40	Yes
V5528	4.5	1174	T8	37.8	37.8	37.8	37.8	37.8	40	43	45	49	51	40	Yes
V5529	4.5	1109	T8	37.6	37.6	37.6	37.6	37.6	40	43	45	49	51	40	Yes
V5532	4.5	1005	T1	37.8	37.8	37.8	37.8	37.8	40	43	45	49	51	40	Yes
V5536	4.5	668	T8	39.1	39.1	39.1	39.1	39.1	40	43	45	49	51	40	Yes
V5538	4.5	951	T8	37.5	37.5	37.5	37.5	37.5	40	43	45	49	51	40	Yes
V5540	4.5	965	T8	37.3	37.3	37.3	37.3	37.3	40	43	45	49	51	40	Yes
V5541	4.5	613	T3	39.2	39.2	39.2	39.2	39.2	40	43	45	49	51	40	Yes
V5542	4.5	1040	T8	37.0	37.0	37.0	37.0	37.0	40	43	45	49	51	40	Yes
V5543	4.5	798	T8	37.7	37.7	37.7	37.7	37.7	40	43	45	49	51	40	Yes
V5544	4.5	824	T3	39.8	39.8	39.8	39.8	39.8	40	43	45	49	51	40	Yes
V5546	4.5	859	T3	39.8	39.8	39.8	39.8	39.8	40	43	45	49	51	40	Yes
V5547	4.5	833	T6	39.8	39.8	39.8	39.8	39.8	40	43	45	49	51	40	Yes
V5549	4.5	686	T6	39.3	39.3	39.3	39.3	39.3	40	43	45	49	51	40	Yes
V5550	4.5	720	T8	39.0	39.0	39.0	39.0	39.0	40	43	45	49	51	40	Yes
V5552	4.5	1285	A1	37.9	37.9	37.9	37.9	37.9	40	43	45	49	51	40	Yes

Point of Reception ID	Receptor height [m]	Distance to nearest source [m]	Nearest source [ID]	Calculated sound pressure level at receptor [dB(A)] at selected wind speed in m/s					Sound level limit [dB(A)] at selected wind speed in m/s					Applicable background sound level NPC 232 (C 3)	Compliant (Yes/No)
				≤6	7	8	9	10	≤6	7	8	9	10		
V5553	4.5	1449	T1	39.8	39.8	39.8	39.8	39.8	40	43	45	49	51	40	Yes
V5554	4.5	1478	T1	40.0	40.0	40.0	40.0	40.0	40	43	45	49	51	40	Yes
V5556	4.5	702	T14	38.8	38.8	38.8	38.8	38.8	40	43	45	49	51	40	Yes
V5557	4.5	772	T16	36.2	36.2	36.2	36.2	36.2	40	43	45	49	51	40	Yes
V5558	4.5	630	T13	39.9	39.9	39.9	39.9	39.9	40	43	45	49	51	40	Yes
V5559	4.5	870	T14	36.2	36.2	36.2	36.2	36.2	40	43	45	49	51	40	Yes
V5560	4.5	925	T13	36.9	36.9	36.9	36.9	36.9	40	43	45	49	51	40	Yes
V5561	4.5	848	T9	37.7	37.7	37.7	37.7	37.7	40	43	45	49	51	40	Yes
V5562	4.5	564	T12	39.7	39.7	39.7	39.7	39.7	40	43	45	49	51	40	Yes
V5563	4.5	818	T13	37.3	37.3	37.3	37.3	37.3	40	43	45	49	51	40	Yes
R5564	1.5	853	T13	35.7	35.7	35.7	35.7	35.7	40	43	45	49	51	40	Yes
V5566	4.5	854	T13	36.7	36.7	36.7	36.7	36.7	40	43	45	49	51	40	Yes
V5567	4.5	679	T12	37.5	37.5	37.5	37.5	37.5	40	43	45	49	51	40	Yes
V5568	4.5	1372	T15	33.0	33.0	33.0	33.0	33.0	40	43	45	49	51	40	Yes
V5571	4.5	869	T14	36.2	36.2	36.2	36.2	36.2	40	43	45	49	51	40	Yes
V5572	4.5	860	T13	38.3	38.3	38.3	38.3	38.3	40	43	45	49	51	40	Yes
V5573	4.5	737	T16	36.6	36.6	36.6	36.6	36.6	40	43	45	49	51	40	Yes
V5574	4.5	818	T2	38.8	38.8	38.8	38.8	38.8	40	43	45	49	51	40	Yes
V5578	4.5	707	TRANS	40.0	40.0	40.0	40.0	40.0	40	43	45	49	51	40	Yes
V5579	4.5	664	TRANS	39.6	39.6	39.6	39.6	39.6	40	43	45	49	51	40	Yes
V5580	4.5	725	TRANS	38.7	38.7	38.7	38.7	38.7	40	43	45	49	51	40	Yes
V5675	4.5	932	TRANS	39.7	39.7	39.7	39.7	39.7	40	43	45	49	51	40	Yes
V5738	4.5	1194	T9	32.6	32.6	32.6	32.6	32.6	40	43	45	49	51	40	Yes
V5907	4.5	1464	T9	31.0	31.0	31.0	31.0	31.0	40	43	45	49	51	40	Yes
V5908	4.5	931	T9	35.6	35.6	35.6	35.6	35.6	40	43	45	49	51	40	Yes
V5933	4.5	1222	T9	33.0	33.0	33.0	33.0	33.0	40	43	45	49	51	40	Yes
V5936	4.5	1274	T8	38.0	38.0	38.0	38.0	38.0	40	43	45	49	51	40	Yes
V5989	4.5	1358	T8	37.2	37.2	37.2	37.2	37.2	40	43	45	49	51	40	Yes
V5996	4.5	1469	T16	39.3	39.3	39.3	39.3	39.3	40	43	45	49	51	40	Yes
V5997	4.5	1168	T16	35.6	35.6	35.6	35.6	35.6	40	43	45	49	51	40	Yes
V5998	4.5	956	T16	36.5	36.5	36.5	36.5	36.5	40	43	45	49	51	40	Yes
V6001	4.5	1214	T8	37.8	37.8	37.8	37.8	37.8	40	43	45	49	51	40	Yes
V6002	4.5	1288	T8	37.0	37.0	37.0	37.0	37.0	40	43	45	49	51	40	Yes
V6014	4.5	1453	T16	32.4	32.4	32.4	32.4	32.4	40	43	45	49	51	40	Yes
V6015	4.5	1358	T16	32.5	32.5	32.5	32.5	32.5	40	43	45	49	51	40	Yes
V6016	4.5	1101	T16	33.5	33.5	33.5	33.5	33.5	40	43	45	49	51	40	Yes
V6018	4.5	676	T16	38.1	38.1	38.1	38.1	38.1	40	43	45	49	51	40	Yes

Point of Reception ID	Receptor height [m]	Distance to nearest source [m]	Nearest source [ID]	Calculated sound pressure level at receptor [dB(A)] at selected wind speed in m/s					Sound level limit [dB(A)] at selected wind speed in m/s					Applicable background sound level NPC 232 (C 3)	Compliant (Yes/No)
				≤6	7	8	9	10	≤6	7	8	9	10		
V6019	4.5	1300	T16	32.2	32.2	32.2	32.2	32.2	40	43	45	49	51	40	Yes
V6022	4.5	1347	T15	33.2	33.2	33.2	33.2	33.2	40	43	45	49	51	40	Yes
V6023	4.5	1206	T16	33.7	33.7	33.7	33.7	33.7	40	43	45	49	51	40	Yes
V6025	4.5	1108	T9	34.3	34.3	34.3	34.3	34.3	40	43	45	49	51	40	Yes
V6037	4.5	922	T9	36.4	36.4	36.4	36.4	36.4	40	43	45	49	51	40	Yes
V6040	4.5	1269	T12	32.2	32.2	32.2	32.2	32.2	40	43	45	49	51	40	Yes
V6050	4.5	883	T16	35.0	35.0	35.0	35.0	35.0	40	43	45	49	51	40	Yes
V6051	4.5	806	T16	35.7	35.7	35.7	35.7	35.7	40	43	45	49	51	40	Yes
V6052	4.5	829	T16	35.6	35.6	35.6	35.6	35.6	40	43	45	49	51	40	Yes
R6118	1.5	1086	T16	31.7	31.7	31.7	31.7	31.7	40	43	45	49	51	40	Yes
V6127	4.5	865	A1	36.5	36.5	36.5	36.5	36.5	40	43	45	49	51	40	Yes
V6128	4.5	726	T13	39.3	39.3	39.3	39.3	39.3	40	43	45	49	51	40	Yes
V6129	4.5	840	T15	36.0	36.0	36.0	36.0	36.0	40	43	45	49	51	40	Yes
V6130	4.5	836	T15	36.1	36.1	36.1	36.1	36.1	40	43	45	49	51	40	Yes
V6132	4.5	715	T13	38.6	38.6	38.6	38.6	38.6	40	43	45	49	51	40	Yes
V6133	4.5	742	T13	38.4	38.4	38.4	38.4	38.4	40	43	45	49	51	40	Yes
V6134	4.5	905	T14	37.9	37.9	37.9	37.9	37.9	40	43	45	49	51	40	Yes
V6135	4.5	922	T14	37.8	37.8	37.8	37.8	37.8	40	43	45	49	51	40	Yes
V6136	4.5	832	T14	38.0	38.0	38.0	38.0	38.0	40	43	45	49	51	40	Yes
V6137	4.5	1338	T16	35.3	35.3	35.3	35.3	35.3	40	43	45	49	51	40	Yes
R6140	1.5	1064	T16	32.0	32.0	32.0	32.0	32.0	40	43	45	49	51	40	Yes
R6141	1.5	1102	T16	31.7	31.7	31.7	31.7	31.7	40	43	45	49	51	40	Yes
V6176	4.5	853	T12	35.6	35.6	35.6	35.6	35.6	40	43	45	49	51	40	Yes
R6178	1.5	927	T12	34.1	34.1	34.1	34.1	34.1	40	43	45	49	51	40	Yes
V6290	4.5	1200	T16	33.4	33.4	33.4	33.4	33.4	40	43	45	49	51	40	Yes

- For single storey receptors, the sound levels were considered at 1.5 m above grade and 30 m horizontally from the dwelling, in 16 evenly spaced directions. In this way, a circle of 16 dummy receptors was created around each single storey receptor. The reported sound level at each receptor is then taken to be the maximum sound level from the circle of dummy receptors. The coordinates of the circle point with the maximum sound level for each of the 94 one-storey receptors are shown in a table in Appendix A (UTM17-NAD83 projection).

Table 7-2 Noise impact assessment summary – participants

Participant ID	Height [m]	Distance to nearest source [m]	Nearest source ID	Max Calculated sound pressure level [dBA]
R16	4.5	621	T2	40.3
R17	1.5	582	T6	38.4
R21	4.5	607	T14	40.2
R26	1.5	796	T16	34.3
R30	4.5	649	T8	40.4
R32	4.5	578	T7	41.5
R33	1.5	770	T2	36.3
R35	4.5	821	T1	38.7
R36	1.5	571	A1	39.8
R165	1.5	563	T11	38.3
R168	4.5	562	T10	39.8
R181	1.5	735	T12	37.8
R188	4.5	573	T12	39.2
R193	4.5	711	T13	38.2
R448	1.5	584	T17	37.2
R2083	4.5	604	T15	39.1
R2098	1.5	551	T3	38.4
V5487	4.5	685	T2	40.5
V5494	4.5	751	T1	38.5
V5495	4.5	464	A1	42.1
V5497	4.5	625	T9	40.0
V5535	4.5	557	T4	41.5
V5539	4.5	720	T7	40.7
V5581	4.5	481	TRANS	39.1
V6116	4.5	559	T8	40.8

Table 7-3 Concordance table showing contributions from Romney and Chatham at shared receptors

UTM coordinates		Noise receptor ID	Distance to nearest source [m]		Nearest source ID		Level of farm [dBA]		Level [dBA]
Easting [m]	Northing [m]		Romney	Chatham	Romney	Chatham	Romney	Chatham ¹	Total ²
385204	4666881	R27	976	1608	T16	CH_T46	34.2	31.1	35.9
383944	4668332	R28	1345	895	T8	CH_T46	32.6	35.0	37.0
382369	4670150	R29	1517	708	T4	CH_T48	32.5	38.9	39.8
382129	4668851	R30 ³	649	1899	T8	CH_T48	40.0	30.0	40.4
381194	4669911	R35 ³	821	1768	T1	CH_T49	37.9	30.8	38.7
380313	4670845	R36 ³	571	1875	A1	CH_T50	39.6	26.4	39.8
383944	4666788	R176	913	1879	T15	CH_T46	36.1	28.1	36.8
386886	4665861	R210	1181	1958	T16	CH_T51	31.1	30.1	33.7
386982	4665885	R211	1273	1930	T16	CH_T51	30.3	30.3	33.4
387285	4666024	R214	1565	1809	T16	CH_T51	28.1	31.2	33.1
387366	4666002	R215	1646	1845	T16	CH_T51	25.6	28.9	30.8
387425	4666068	R216	1705	1793	T16	CH_T51	25.2	29.4	31.0
386217	4667306	R217	1347	950	T16	CH_T51	28.2	35.4	36.1
385049	4667225	R218	1350	1240	T16	CH_T46	30.2	30.6	33.3
385000	4667233	R219	1382	1224	T16	CH_T46	30.1	30.6	33.2
384989	4667245	R220	1398	1210	T16	CH_T46	30.1	30.6	33.3
384800	4667464	R221	1684	982	T16	CH_T46	31.5	33.9	35.9
384214	4667009	R222	1183	1563	T15	CH_T46	34.3	29.8	35.6
384575	4667728	R223	1850	761	T11	CH_T46	31.3	35.8	37.1
384219	4667997	R224	1669	759	T8	CH_T46	32.4	36.2	37.7
383812	4668484	R225	1214	1020	T8	CH_T46	31.1	32.5	34.8
384459	4669024	R226	1959	688	T8	CH_T46	29.0	38.8	39.2
383474	4670050	R228	1863	744	T8	CH_T48	29.6	39.5	40.0
381763	4670825	R230	1430	819	T1	CH_T50	32.5	38.3	39.3
381314	4671326	R233	1357	766	A1	CH_T50	31.2	35.2	36.7
381240	4671416	R234	1288	810	A1	CH_T50	33.1	36.3	38.2
381611	4671987	R235	1794	570	A1	CH_T50	29.3	39.3	39.9
381318	4672253	R236	1666	965	A1	CH_T50	29.3	34.6	36.2
381411	4672434	R237	1849	1038	A1	CH_T50	28.3	34.1	35.7
381330	4672394	R238	1761	1058	A1	CH_T50	26.7	31.9	33.6
382137	4670400	R240	1597	724	T4	CH_T49	30.4	37.5	38.2
382375	4670235	R241 ³	1587	656	T4	CH_T48	32.2	39.8	40.5
382610	4669981	R242	1568	673	T4	CH_T48	30.5	37.1	37.9
382745	4669738	R243	1341	853	T8	CH_T48	33.1	36.8	38.3
383560	4668904	R244	1082	1110	T8	CH_T47	31.7	32.8	35.1
383275	4668009	R246	782	1616	T8	CH_T46	37.1	30.4	37.9
381237	4669820	R254	854	1787	T4	CH_T49	36.2	28.5	36.8

UTM coordinates		Noise receptor ID	Distance to nearest source [m]		Nearest source ID		Level of farm [dBA]		Level [dBA]
Easting [m]	Northing [m]		Romney	Chatham	Romney	Chatham	Romney	Chatham ¹	Total ²
381478	4670071	R255	1045	1444	T1	CH_T49	36.1	32.9	37.8
380965	4671517	R256	1032	1068	A1	CH_T50	34.4	33.7	37.3
380448	4672298	R260	1119	1728	A1	CH_T50	32.9	29.4	35.8
381335	4672608	R460	1905	1224	A1	CH_T50	27.8	32.8	34.9
381400	4672677	R462	2000	1247	A1	CH_T50	25.4	30.7	32.6
385426	4666789	R818	792	1760	T16	CH_T46	35.7	31.5	37.1
381393	4672145	R820	1670	838	A1	CH_T50	29.5	35.8	37.1
385515	4666841	R821	814	1744	T16	CH_T46	33.8	29.7	35.2
387594	4666162	R1383	1877	1750	T16	CH_T51	26.2	32.2	33.4
387636	4666194	R1384	1921	1733	T16	CH_T51	23.9	30.2	31.3
387539	4666127	R1385	1820	1766	T16	CH_T51	24.5	29.8	31.1
387553	4665993	R2155	1834	1898	T16	CH_T51	24.5	29.0	30.5
387539	4665923	R2156	1823	1961	T16	CH_T51	24.5	28.6	30.2
384147	4667031	V5021	1187	1571	T15	CH_T46	34.4	29.7	35.7
387196	4665917	V5171	1482	1905	T16	CH_T51	28.7	30.6	32.9
387677	4666220	V5194	1963	1725	T16	CH_T51	25.7	32.5	33.6
380268	4672420	V5418	1170	1943	A1	CH_T50	31.9	27.9	35.2
384114	4666806	V5468	960	1789	T15	CH_T46	35.4	28.7	36.3
384753	4667377	V5469	1640	1071	T16	CH_T46	31.8	33.2	35.6
380245	4670927	V5495 ³	464	1907	A1	CH_T50	41.8	28.4	42.1
385067	4667015	V5499	1163	1449	T16	CH_T46	33.2	31.7	35.5
384109	4666962	V5520	1110	1650	T15	CH_T46	34.8	29.3	35.9
383985	4666855	V5521	984	1801	T15	CH_T46	35.7	28.6	36.5
381199	4672229	V5524	1556	1041	A1	CH_T50	29.9	33.9	35.9
381026	4671608	V5525	1114	1003	A1	CH_T50	33.6	34.2	37.2
380464	4672236	V5526	1072	1689	A1	CH_T50	32.9	29.2	35.6
382867	4669548	V5528	1174	1022	T8	CH_T48	33.7	35.6	37.8
382946	4669458	V5529	1109	1110	T8	CH_T48	33.9	35.2	37.6
381451	4670165	V5532	1005	1415	T1	CH_T49	36.0	33.1	37.8
382501	4669065	V5536	668	1566	T8	CH_T48	38.2	32.0	39.1
383311	4669038	V5538	951	1175	T8	CH_T47	34.5	34.4	37.5
383424	4668908	V5540	965	1190	T8	CH_T47	34.4	34.2	37.3
383594	4668711	V5542	1040	1257	T8	CH_T47	33.9	34.1	37.0
383335	4668094	V5543	798	1537	T8	CH_T46	36.7	30.9	37.7
383027	4667825	V5550	720	1908	T8	CH_T46	38.5	29.0	39.0
384674	4667468	V5551	1759	990	T16	CH_T46	31.7	33.7	35.8
381210	4671578	V5552	1285	819	A1	CH_T50	32.7	36.1	37.9
381504	4671252	V5553	1449	630	T1	CH_T50	32.3	38.8	39.8

UTM coordinates		Noise receptor ID	Distance to nearest source [m]		Nearest source ID		Level of farm [dBA]		Level [dBA]
Easting [m]	Northing [m]		Romney	Chatham	Romney	Chatham	Romney	Chatham ¹	Total ²
381727	4671002	V5554	1478	670	T1	CH_T50	32.1	39.2	40.0
381940	4670584	V5555	1525	786	T1	CH_T49	32.5	38.4	39.4
382956	4669629	V5936	1274	940	T8	CH_T48	33.0	36.4	38.0
382449	4670195	V5975 ⁴	1602	617	T4	CH_T48	32.1	40.0	40.7
382673	4669944	V5979	1542	678	T8	CH_T48	32.5	38.6	39.5
383957	4668477	V5989	1358	875	T8	CH_T46	32.3	35.5	37.2
386330	4667390	V5996	1469	809	T16	CH_T51	29.3	38.8	39.3
385168	4667083	V5997	1168	1403	T16	CH_T46	32.9	32.2	35.6
385678	4667009	V5998	956	1544	T16	CH_T52	33.8	33.2	36.5
383035	4669539	V6001	1214	1034	T8	CH_T48	33.2	35.9	37.8
383878	4668568	V6002	1288	961	T8	CH_T46	32.5	35.1	37.0
385504	4666694	V6018	676	1876	T16	CH_T46	37.0	31.3	38.1
382198	4668793	V6116 ³	559	1924	T8	CH_T48	40.5	29.9	40.8
384976	4667166	V6137	1338	1288	T16	CH_T46	32.4	32.3	35.3
381538	4671972	V6139	1721	616	A1	CH_T50	29.6	38.6	39.3
387637	4665991	R6183	1917	1925	T16	CH_T51	24.0	29.0	30.4

1. Circle of receptors method used for one storey receptors, as described in Section 7. Location of maximum sound level in the 30 m circle may vary depending on the sources considered.
2. Total sound level includes contributions from all sources and might not always be equal to the sum of the two previous columns (i.e. Total may also include Richardson, Comber, South Kent, Gracey, Pointe aux Roches turbine contributions).
3. R30, R35, R36, R241, V5495, and V6116 are Participants of the Romney Project.
4. V5975 is a Participant of the Chatham project since there is an operational turbine on the property on which it is located.

Table 7-4 Concordance table showing contributions from Romney and Comber at shared receptors

UTM coordinates		Noise receptor ID	Distance to nearest source [m]		Nearest source ID		Level of farm [dBA]		Level [dBA]
Easting [m]	Northing [m]		Romney	Comber	Romney	Comber	Romney	Comber ¹	Total ²
R260	380448	4672298	1119	1706	A1	Com14	32.9	29.1	35.8
R261	378862	4672092	1357	1796	A1	Com14	30.5	31.9	34.6
R262	378925	4672282	1431	1596	A1	Com14	29.9	32.5	34.8
R263	378092	4671989	1993	1393	A1	Com17	27.7	34.0	35.1
R326	375077	4670752	1590	1128	T17	Com30	27.4	34.7	35.4
R327	375231	4670803	1484	1192	T17	Com30	28.2	34.4	35.3
R343	375107	4671228	1843	830	T17	Com30	25.8	37.2	37.5
R344	375182	4671197	1767	911	T17	Com30	26.2	36.6	37.0
R375	380058	4673283	1994	688	A1	Com14	24.4	35.7	36.4
R376	380096	4673204	1918	771	A1	Com14	24.8	34.6	35.5
R436	378911	4672901	1920	1064	A1	Com14	26.8	35.5	36.4

UTM coordinates		Noise receptor ID	Distance to nearest source [m]		Nearest source ID		Level of farm [dBA]		Level [dBA]
Easting [m]	Northing [m]		Romney	Comber	Romney	Comber	Romney	Comber ¹	Total ²
R446	374567	4669524	1962	1832	T17	Com32	24.8	31.1	32.0
R449	375897	4670844	1029	1708	T17	Com30	32.2	33.0	35.6
R450	376168	4670829	892	1924	T17	Com15	32.3	30.2	34.3
R819	379714	4671914	668	1844	A1	Com14	35.8	26.9	36.5
V5236	378848	4672469	1618	1462	A1	Com14	28.8	33.5	35.2
V5241	375222	4671467	1935	852	T17	Com30	25.2	37.5	37.7
V5264	374747	4670841	1924	881	T17	Com30	25.0	36.5	36.8
V5277	379691	4671833	604	1922	A1	Com14	38.1	28.9	38.8
V5279	375059	4670818	1638	1066	T17	Com30	27.1	35.1	35.7
V5290	375825	4670756	1003	1689	T17	Com30	32.5	32.8	35.6
V5291	375176	4670766	1511	1181	T17	Com30	28.0	34.4	35.3
V5350	376271	4670842	875	1934	T17	Com15	34.0	32.5	36.3
V5414	380196	4673171	1894	866	A1	Com14	26.9	35.1	36.5
V5415	380558	4673143	1946	1175	A1	Com14	26.5	32.1	34.8
V5416	379656	4673212	1945	548	A1	Com14	26.6	39.5	40.0
V5417	379808	4673201	1915	606	A1	Com14	26.7	38.5	39.2
V5418	380268	4672420	1170	1511	A1	Com14	31.9	30.0	35.2
V5420	378940	4672010	1246	1844	A1	Com14	31.3	31.4	34.7
V5442	378812	4671899	1297	1993	A1	Com14	31.0	31.2	34.5
V5496	379817	4671913	637	1856	A1	Com14	37.6	29.0	38.5
V5526	380464	4672236	1072	1768	A1	Com14	32.9	28.3	35.6
V5527	379846	4672332	1046	1448	A1	Com14	32.9	30.9	35.7
V5607	375066	4670937	1696	980	T17	Com30	26.7	35.8	36.3
V6127	379711	4672121	865	1637	A1	Com14	34.7	30.2	36.5

1. Circle of receptors method used for one storey receptors, as described in Section 7. Location of maximum sound level in the 30 m circle may vary depending on the sources considered.
2. Total sound level includes contributions from all sources and might not always be equal to the sum of the two previous columns (i.e. Total may also include Richardson, Port Alma, Chatham, South Kent, Gracey, Pointe aux Roches turbine contributions).

Table 7-5 Concordance table for the Romney transformer and neighboring projects at shared receptors

UTM coordinates		Noise receptor ID	Distance to nearest source [m]						Nearest source ID						Level of farm [dBA]						Level [dBA]
Easting [m]	Northing [m]		Romney	Richardson	South Kent	PAR	Gracey	Comber	Romney	Richardson	South Kent	PAR	Gracey	Comber	Romney	Richardson	South Kent	PAR	Gracey	Comber	Total
378799	4677380	R494	809	938	3576	4771	3909	1309	Transf	Rich4	P080	PAR2	GRA4	Com5	28.8	36.3	20.7	14.8	20.5	35.2	39.4
378931	4677464	R495	741	855	3455	4675	3871	1367	Transf	Rich4	P080	PAR2	GRA4	Com3	29.1	35.5	19.2	13.5	18.5	32.2	38.0
378329	4677501	R497	817	1421	4057	4724	3617	956	Transf	Rich4	P080	PAR2	GRA5	Com5	29.8	32.3	19.2	15.0	21.5	37.9	39.6
379321	4678790	R996	816	1171	3310	3335	2877	733	Transf	Rich5	P154	PAR2	GRA4	Com1	29.0	31.3	22.0	19.8	23.5	37.1	38.9
378952	4678823	R997	660	1380	3671	3320	2645	1047	Transf	Rich5	P154	PAR2	GRA4	Com1	30.4	28.1	18.7	18.6	22.4	33.3	36.2
378261	4678867	R2034	849	1896	4346	3419	2329	634	Transf	Rich5	P154	PAR2	GRA4	Com3	30.7	27.2	15.9	21.5	26.6	38.5	39.7
378268	4678809	R2035	800	1856	4325	3472	2387	592	Transf	Rich5	P154	PAR2	GRA4	Com3	30.4	25.5	13.8	19.0	24.1	37.5	38.8
378391	4678895	R2036	802	1814	4229	3355	2343	738	Transf	Rich5	P154	PAR2	GRA4	Com3	29.3	25.6	14.0	19.7	24.2	35.5	37.1
378465	4678849	R2037	729	1728	4145	3380	2411	760	Transf	Rich5	P154	PAR2	GRA4	Com3	30.8	28.0	16.5	21.5	26.0	37.1	38.8
378488	4678843	R2038	713	1707	4121	3381	2425	773	Transf	Rich5	P154	PAR2	GRA4	Com3	31.0	28.1	16.6	21.4	25.9	37.0	38.7
378544	4678774	R2039	629	1619	4049	3434	2509	777	Transf	Rich5	P154	PAR2	GRA4	Com3	31.0	26.8	14.6	18.9	23.3	35.1	37.4
379174	4678040	V5262	429	675	3295	4087	3439	1320	Transf	Rich5	P154	PAR2	GRA4	Com3	31.8	36.9	22.3	16.6	21.7	34.2	39.7
378371	4678771	V5578	707	1751	4215	3480	2453	637	Transf	Rich5	P154	PAR2	GRA4	Com3	32.2	28.0	16.3	20.8	25.9	38.5	40.0
378442	4678766	V5579	664	1692	4145	3467	2482	689	Transf	Rich5	P154	PAR2	GRA4	Com3	32.2	28.3	16.5	20.8	25.7	37.9	39.6
379278	4678706	V5580	725	1111	3325	3419	2920	817	Transf	Rich5	P154	PAR2	GRA4	Com1	30.2	31.9	21.9	19.5	23.4	36.4	38.7
379248	4678254	V5581	481	751	3250	3871	3286	1166	Transf	Rich5	P154	PAR2	GRA4	Com1	30.8	35.7	22.3	17.3	22.2	34.5	39.1
378279	4677397	V5675	932	1440	4094	4836	3679	855	Transf	Rich4	P080	PAR2	GRA5	Com5	28.4	32.2	19.1	14.7	21.2	38.3	39.7

V5581 is a participant of the Romney project

Circle of receptors method used for one storey receptors, as described in Section 7. Location of maximum sound level in the 30 m circle may vary depending on the sources considered.



8 CONCLUSION

Based on the approach presented in this NIA, the Project is compliant with the MOECC noise limits at all PoR within 1,500 m of the Project's turbines, and within 2,000 m in cases of cumulative impact at shared receptors with adjacent wind farms, and 1,000 m of the Project's transformer, for wind speeds of 6, 7, 8, 9, and 10 m/s.

9 REFERENCES

- [1] Ontario Regulation 359/09 (Renewable Energy Approvals (REA))
- [2] MOECC Noise Guidelines for Wind Farms, May 2016.
- [3] Romney Wind Farm Turbine Layout, received via email from the Proponent (R. Plamondon) to DNV GL, "Turbines_Lv68_18xV136_132m.shp", 24 July 2017.
- [4] Municipality of Chatham-Kent. Zoning maps. <https://gismapapp.chatham-kent.ca/Chatham-KentWeb/WebPages/Map/FundyViewer.aspx#>
- [5] Town of Lakeshore. Zoning maps. http://gisweb.countyofessex.on.ca/html/lakeshore272/Index.html?Viewer=public_html5
- [6] GL Garrad Hassan. Pointe-aux-Roches Wind Farm Noise Impact Assessment. Document No.: 800415-CAMO-R-04-B. 24 March 2014.
- [7] Hatch. Noise Assessment Report for South Kent Wind Project. 7 May 2013.
- [8] Stantec. Gosfield Comber Wind Energy Project Minor Modification Report. August 2009.
- [9] Aercoustics Engineering Limited. Environmental Noise Impact Assessment - KEC Wind Power Project Chatham Kent, Ontario. 11 November 2009.
- [10] DMS 0069-3308_V01, "V136-3.45 MW (CAN) Third octave noise emission" received from the Proponent to DNV GL, 20 Sep 2017.
- [11] DMS 0069-3309_V01, "V136-3.6 MW (CAN) Third octave noise emission" received from the Proponent to DNV GL, 20 Sep 2017
- [12] International Electrotechnical Commission (IEC), 2012. IEC 61400 – 11 Ed. 3.0 Wind turbines– Part 11: Acoustic noise measurement techniques. 58 p.
- [13] IEEE C57.12.90 – Distribution, Power, and Regulating Transformers. 2010
- [14] Handbook of Acoustics – Malcolm J. Crocker, 1998.
- [15] International Organization for Standardization (ISO), 1993. Acoustics - Attenuation of Sound During Propagation Outdoors - Calculation of the Absorption of Sound by the Atmosphere. ISO 9613-1. 33 p.
- [16] International Organization for Standardization (ISO), 1996. Acoustics - Attenuation of Sound During Propagation Outdoors - General Method of Calculation. ISO 9613-2. 25 p.
- [17] Institute of Acoustics. A Good Practice Guide to the Application of ETSU-R-97 for the Assessment and Rating of Wind Turbine Noise. May 2013.

APPENDIX A – COORDINATES OF POINTS OF RECEPTION

Coordinates of all modeled Points of Reception and Vacant Lot Receptors for the Romney Wind Energy Centre (UTM17-NAD83 projection) are given in the table below:

ID	Parcel Ident. Number	Easting [m]	Northing [m]	Base Elevation [m]
R14	750890136	379251	4666430	185
R15	750820080	379328	4666975	181
R18	008330013	380262	4665410	185
R19	008470055	382270	4664671	180
R20	008340030	382345	4664724	183
R22	008340090	382867	4665980	180
R23	008480098	385722	4665334	185
R24	008480108	385855	4665423	187
R25	008480073	386002	4665439	188
R27	008340048	385204	4666881	175
R28	008340017	383944	4668332	182
R34	008310010	380769	4669431	185
R37	750820107	379206	4668092	185
R145	751010077	378822	4663269	180
R146	750900086	379162	4663734	183
R147	750900087	379159	4663797	183
R149	750900088	379156	4663873	184
R150	750890097	378507	4663989	185
R151	750890116	378408	4663993	185
R152	750900116	378402	4663922	185
R153	750890099	379170	4663998	185
R154	750890121	379078	4664015	185
R155	750890105	379243	4665073	185
R156	008330017	379325	4665277	180
R157	750890111	379314	4666086	180
R158	008330010	379426	4666352	180
R159	008330087	379579	4666525	180
R160	008330004	380111	4666906	180
R161	008330083	380816	4665931	183
R162	008310061	381165	4666190	182
R163	008340003	381450	4666333	183
R164	008310052	382122	4666997	185
R166	008330073	380434	4665539	184
R167	008330050	380320	4665338	185
R169	008330016	379755	4664945	181
R170	008340025	382137	4664950	181
R171	008340007	382364	4665386	184
R172	008340009	382756	4665843	185
R174	008340040	383634	4666420	190
R175	008330104	381671	4664819	181
R176	008340020	383944	4666788	190
R177	008470043	381011	4664118	185
R178	008470042	380907	4664017	185
R179	008330049	380923	4664124	185
R180	008330071	380713	4663944	185
R182	008470034	380528	4663685	185
R183	008330042	380393	4663691	185
R184	008330036	380151	4663444	185
R185	008470019	380401	4663553	185
R186	008330065	380071	4663400	185
R189	008470162	381870	4663134	183
R190	008470046	382068	4663298	176
R191	008470047	382134	4663370	181
R192	008470048	382187	4663401	184
R194	008470156	382378	4663468	185
R195	008470142	382557	4663721	184
R196	008470144	383021	4663617	180
R197	008340059	383135	4664227	185
R198	008480002	383417	4664364	185
R199	008340061	383465	4664512	185
R200	008480107	383725	4664498	185
R201	008480032	384029	4664871	185
R202	008340039	383968	4665131	185
R203	008480037	384647	4665158	185
R204	008480037	384620	4665164	185
R205	008480039	384772	4664748	185
R206	008480039	384802	4664761	185
R207	008480094	385043	4664904	185
R208	008480065	385349	4665236	185
R209	008490002	386615	4665626	190
R210	008490005	386886	4665861	190
R211	008490062	386982	4665885	190
R212	008490070	387160	4665631	183
R217	008350029	386217	4667306	177
R218	008350071	385049	4667225	189
R219	008350023	385000	4667233	189

ID	Parcel Ident. Number	Easting [m]	Northing [m]	Base Elevation [m]
R220	008350023	384988	4667245	189
R222	008340057	384214	4667009	188
R225	008310037	383812	4668484	185
R230	008300023	381763	4670825	185
R233	008300022	381314	4671326	185
R234	008300019	381240	4671416	185
R243	008310048	382745	4669738	185
R244	008320039	383560	4668904	185
R246	008310057	383275	4668009	185
R247	008310065	382705	4667502	185
R248	008310063	381274	4667995	184
R249	008310044	380995	4667848	183
R250	008330075	379679	4667629	180
R251	008310071	379546	4668112	180
R252	008300011	380508	4669282	185
R253	008300044	380944	4669687	185
R254	008310013	381236	4669820	185
R255	008310059	381478	4670071	185
R256	008300057	380965	4671517	185
V257	008300016	379882	4670471	185
R258	750810075	379642	4670673	185
R260	008300053	380448	4672297	185
R261	750800094	378862	4672092	184
R262	750790059	378925	4672282	184
R265	750810067	378840	4671760	184
R266	750810070	378905	4671740	184
R267	750810068	378823	4671589	184
R268	750810109	378774	4670779	185
R271	008300047	379649	4669707	185
R275	750810098	377788	4669321	185
R276	008300042	379602	4669095	185
R277	750820049	379497	4668966	185
R320	750810095	375225	4669495	185
R321	750810089	375826	4669451	185
R322	750810054	376125	4669441	185
R323	750820036	376141	4669336	185
R324	750810059	377156	4669374	185
R325	750810050	375096	4669743	185
R327	750810062	375231	4670803	183
R328	750810043	376796	4670807	184
R329	750810057	377244	4670673	184
R330	750810048	377394	4670739	184
R442	750810100	378864	4671406	184
R443	750810084	379558	4669438	185

ID	Parcel Ident. Number	Easting [m]	Northing [m]	Base Elevation [m]
R449	750810038	375897	4670844	183
R450	750810088	376168	4670829	183
R494	750770101	378799	4677380	180
R495	750770098	378931	4677464	180
R497	750770097	378329	4677501	180
R560	008470009	380671	4662086	180
R561	008470011	380719	4662148	181
R562	008470012	380741	4662164	181
R563	008470013	380764	4662180	181
R565	750900094	378916	4663404	185
R569	751010072	379121	4663251	185
R581	750810091	378874	4670813	185
R624	008330030	379446	4662847	180
R625	008330031	379386	4662780	180
R628	008330034	379816	4663164	185
R629	008470132	380908	4662288	181
R630	008470063	381441	4662648	182
R634	008470165	380940	4662330	181
R635	008470060	381160	4662406	182
R636	008470022	381060	4662437	182
R637	008470138	381217	4662456	182
R638	008470023	381083	4662457	182
R639	008470024	381104	4662476	182
R640	008470062	381242	4662487	182
R641	008470025	381124	4662494	182
R643	008470026	381155	4662508	182
R645	008470027	381170	4662533	182
R647	008470028	381194	4662553	182
R650	008470029	381218	4662576	182
R652	008470030	381241	4662594	182
R660	008470064	381524	4662710	183
R665	008470033	381471	4662778	183
R669	008470006	379632	4662911	181
R671	008370055	379101	4662948	182
R672	751010062	379105	4662970	182
R675	751010063	379105	4662999	182
R676	751010064	379107	4663020	182
R677	751010065	379110	4663042	182
R678	751010066	379109	4663059	182
R680	751010067	379114	4663092	182
R681	008470173	379858	4663114	185
R685	751010068	379115	4663142	183
R686	751010069	379114	4663167	184
R687	751010070	379118	4663200	184

ID	Parcel Ident. Number	Easting [m]	Northing [m]	Base Elevation [m]
R688	751010071	379122	4663221	185
R689	751010073	379126	4663278	185
R690	751010215	379128	4663299	185
R691	751010075	379115	4663332	185
R701	008470045	381239	4664324	183
R704	008330037	379436	4664587	182
R720	750810056	376704	4669425	185
R818	008350026	385426	4666789	185
R819	750790062	379714	4671914	185
R821	008350027	385515	4666841	185
R823	008490004	386737	4665787	190
R825	008480052	385478	4664625	180
R910	008480106	383794	4664480	185
R996	750760049	379321	4678790	179
R997	750760048	378952	4678823	179
R2034	750760045	378261	4678867	180
R2035	750770068	378268	4678809	180
R2036	750760046	378391	4678895	179
R2037	750760047	378465	4678849	179
R2038	750760047	378488	4678843	179
R2039	750770072	378544	4678774	179
R2072	750810071	378886	4671703	184
R2074	750890135	378650	4666514	186
R2082	750900089	379086	4663875	185
R2085	008470041	380989	4664092	185
R2086	008470036	380518	4663666	185
R2087	008470020	380438	4663565	185
R2088	008470007	379552	4662837	180
R2089	008330030	379420	4662827	180
R2091	751010062	379104	4662986	182
R2092	751010076	379112	4663357	185
R2093	008330016	379774	4664951	181
R2094	008330015	379959	4665143	185
R2095	008310050	380253	4667085	181
R2096	008330082	379960	4666842	180
R2097	008300013	380673	4669453	185
R2099	008310042	380070	4668796	185
R2143	008470014	380783	4662202	181
R2144	008470031	381270	4662605	182
R2145	008470067	382017	4663090	181
R2146	008470151	382178	4662971	175
R2152	008480054	385521	4664652	183
R2153	008480056	385556	4664679	185
R2154	008480058	385624	4664695	183

ID	Parcel Ident. Number	Easting [m]	Northing [m]	Base Elevation [m]
V5002	750900098	379157	4663837	184
V5009	750820050	379507	4668584	184
R5016	008340031	382490	4664539	180
R5017	008300017	379839	4670414	185
V5019	008330002	380126	4667127	181
V5021	008340079	384147	4667031	188
V5023	008340094	383013	4665833	180
V5024	008480034	384456	4665116	185
V5025	008470053	382863	4663981	183
R5026	008480033	384155	4665015	185
V5028	008470051	382470	4663653	185
V5029	008480069	385988	4665405	187
V5030	008330109	379426	4666511	180
V5102	008330064	379923	4663305	185
V5171	008490010	387196	4665917	190
V5172	008490054	387158	4665654	184
V5174	008490071	387152	4665617	182
V5175	008490052	387136	4665613	182
V5177	008480064	385260	4665112	185
R5184	008480061	385673	4664774	180
R5185	008480062	385693	4664794	180
V5190	008470157	382149	4662270	180
V5193	008470010	380583	4662072	180
R5199	008480060	385645	4664751	181
R5200	008480059	385652	4664710	181
V5201	008480053	385519	4664621	181
R5202	008480057	385568	4664698	185
V5203	008480051	385471	4664584	180
V5244	750890110	379232	4665294	180
V5245	750890104	379228	4665168	182
V5246	750890101	378704	4663993	185
V5247	750890119	379194	4664775	185
V5248	750890120	379172	4664463	185
V5262	750770076	379174	4678040	180
V5276	750810083	379602	4670473	185
V5277	750810074	379691	4671833	185
V5288	750900090	378753	4663870	185
V5289	750810053	376182	4670728	184
V5290	750810052	375825	4670756	183
V5298	750830074	375750	4669352	185
V5317	750820043	377639	4669232	185
V5318	750820037	376734	4669291	185
V5321	750810094	375108	4669518	185
V5328	750810082	379516	4669229	185

ID	Parcel Ident. Number	Easting [m]	Northing [m]	Base Elevation [m]
V5339	750820078	379425	4667971	182
V5340	750820079	379393	4667539	181
V5348	750810041	376505	4670823	183
V5350	750810039	376271	4670841	183
V5351	750810042	376889	4670793	184
V5352	750810058	377413	4670631	184
V5353	750810060	377299	4669374	185
V5354	750810099	377699	4669346	185
V5357	750810103	377704	4670602	184
V5396	750820048	379508	4669109	185
V5397	750820108	379457	4668410	182
V5399	750890129	379297	4666162	181
V5402	750810106	377505	4670740	184
V5403	750810108	377111	4670775	184
V5418	750790063	380268	4672420	185
V5420	750790060	378940	4672010	184
V5442	750810066	378812	4671899	184
V5444	750810092	378877	4671092	185
V5463	008330091	381085	4665977	183
V5466	008330018	379313	4664602	183
V5467	008330026	379210	4663142	182
V5468	008340044	384114	4666806	190
V5470	008330070	380647	4663897	185
V5471	008330068	380776	4665711	184
V5473	008300050	379689	4669980	185
V5475	008330090	381952	4665014	181
V5476	008330043	380503	4663789	185
V5477	008330044	379800	4664867	182
V5478	008330051	380547	4665513	185
V5479	008330053	381131	4664318	183
V5480	008330054	381411	4664633	182
V5482	008340002	381560	4666391	183
V5484	008340029	382644	4665507	181
V5485	008340077	382555	4665591	182
V5486	008340010	381882	4666672	185
V5488	008340043	384504	4665459	185
V5489	008340001	381175	4666056	183
V5490	008340034	383684	4664741	185
V5496	008300003	379817	4671912	185
V5498	008330011	379429	4666208	180
V5499	008340047	385067	4667015	186
V5500	008340074	384956	4665849	185
V5503	008340004	381708	4665463	184
V5504	008340005	382020	4665117	182

ID	Parcel Ident. Number	Easting [m]	Northing [m]	Base Elevation [m]
V5506	008340024	382105	4665022	181
V5507	008300010	380278	4669123	185
V5508	008330005	380405	4666760	181
V5509	008310011	381057	4669662	185
V5510	008340023	382488	4665401	183
V5511	008340006	382307	4665371	184
V5513	008330105	381581	4664752	182
V5514	008340081	383316	4666105	185
V5515	008340016	383578	4666497	190
V5516	008340012	382326	4667055	185
V5517	008340091	383236	4666194	184
V5518	008340011	382170	4666923	185
V5519	008340015	382872	4667534	185
V5520	008340080	384109	4666962	189
V5521	008340019	383985	4666855	190
V5522	008310073	379544	4668022	180
V5523	008340096	383125	4665936	180
V5525	008300058	381026	4671608	185
V5526	008300054	380464	4672236	185
V5527	008300004	379846	4672332	185
V5528	008310019	382867	4669548	185
V5529	008310033	382946	4669458	185
V5532	008300021	381451	4670165	185
V5536	008310031	382501	4669065	185
V5538	008310034	383311	4669038	185
V5540	008310035	383424	4668908	185
V5541	008310006	380307	4668991	185
V5542	008310036	383594	4668711	185
V5543	008310056	383335	4668094	185
V5544	008310008	381111	4667981	183
V5546	008310045	381038	4667926	183
V5547	008310024	381045	4667767	183
V5549	008310054	381866	4666817	185
V5550	008310066	383027	4667825	185
V5552	008300025	381210	4671578	185
V5553	008300026	381504	4671252	185
V5554	008300027	381727	4671002	185
V5556	008340097	382873	4665709	180
V5557	008480075	386322	4665569	190
V5558	008470136	381309	4664338	182
V5559	008480001	383285	4664222	185
V5560	008470054	382801	4663973	183
V5561	008470018	380302	4663455	185
V5562	008470161	381787	4663090	184

ID	Parcel Ident. Number	Easting [m]	Northing [m]	Base Elevation [m]
V5563	008470153	382345	4663403	184
R5564	008470072	382250	4663308	182
V5566	008470075	382613	4663636	183
V5567	008470032	381346	4662706	183
V5568	008480031	384643	4664748	185
V5571	008480105	383640	4664530	185
V5572	008470149	382031	4664924	181
V5573	008480099	385629	4665322	185
V5574	008330110	380085	4667090	181
V5578	750770069	378371	4678771	179
V5579	750770071	378442	4678766	179
V5580	750770074	379278	4678706	179
V5675	750770094	378279	4677397	180
V5738	751010074	379010	4663301	184
V5907	008330025	379185	4662853	181
V5908	008330033	379862	4663233	185
V5933	008330108	379563	4662973	182
V5936	008320006	382956	4669629	185
V5989	008350001	383957	4668477	182
V5996	008350031	386330	4667390	179
V5997	008350025	385168	4667083	185
V5998	008350028	385678	4667009	182
V6001	008320015	383035	4669538	185
V6002	008320040	383878	4668568	185
V6014	008490048	387142	4665752	187
V6015	008490047	387030	4665696	186
V6016	008490003	386700	4665550	188

ID	Parcel Ident. Number	Easting [m]	Northing [m]	Base Elevation [m]
V6018	008490001	385504	4666694	186
V6019	008480063	385528	4664768	181
V6022	008480035	384726	4664842	185
V6023	008480036	385067	4665040	185
V6025	008470174	379829	4663056	185
V6037	008470017	380100	4663281	185
V6040	008470015	380804	4662219	181
V6050	008480071	386285	4665375	187
V6051	008480109	385966	4665286	185
V6052	008480067	385744	4665225	185
R6118	008490004	386765	4665755	190
V6127	750790061	379711	4672121	185
V6128	008330055	381230	4664395	183
V6129	008340052	384345	4665188	185
V6130	008340053	384326	4665181	185
V6132	008330107	381673	4664760	181
V6133	008330106	381736	4664805	181
V6134	008330101	382008	4665002	181
V6135	008330063	381991	4665018	181
V6136	008340076	382083	4665056	182
V6137	008340063	384976	4667166	190
R6140	008490005	386755	4665803	190
R6141	008490005	386785	4665769	190
V6176	008470058	381346	4662532	182
R6178	008470151	382089	4662888	180
V6290	008480040	385190	4664978	185

For single storey receptors, the sound levels were considered at 1.5 m above grade and 30 m horizontally from the dwelling, in 16 evenly spaced directions. In this way, a circle of 16 dummy receptors was created around each single storey receptor. The reported sound level at each receptor is then taken to be the maximum sound level from the circle of dummy receptors. The table below shows the coordinates of the circle point with the maximum sound level for each of the 94 one-storey receptors (UTM17-NAD83 projection).

Receptor ID	Centre of Building Receptor Location		Maximum Sound Level of Model Location			
	Easting [m]	Northing [m]	Model Receptor ID	Easting [m]	Northing [m]	Sound Level [dBA]
R18	380262	4665410	R18.01	380262	4665440	36.5
R22	382867	4665980	R22.03	382888	4666002	36.0
R23	385722	4665334	R23.01	385722	4665364	35.3
R37	379206	4668092	R37.04	379234	4668104	33.3
R149	379156	4663874	R149.03	379177	4663895	35.3
R150	378507	4663989	R150.04	378535	4664001	29.7
R172	382756	4665843	R172.07	382777	4665821	36.1
R174	383634	4666420	R174.07	383655	4666399	37.7
R178	380907	4664017	R178.07	380928	4663996	37.9
R179	380923	4664124	R179.04	380951	4664136	37.6
R180	380713	4663944	R180.01	380713	4663974	37.7
R183	380393	4663691	R183.01	380393	4663721	37.4
R185	380401	4663553	R185.01	380401	4663583	36.6
R189	381870	4663134	R189.14	381842	4663146	37.8
R190	382068	4663298	R190.14	382040	4663310	37.0
R191	382134	4663370	R191.14	382107	4663382	37.0
R192	382187	4663401	R192.01	382187	4663431	36.8
R196	383021	4663617	R196.14	382993	4663628	32.4
R198	383417	4664364	R198.15	383396	4664386	34.9
R204	384620	4665164	R204.01	384620	4665194	32.9
R205	384772	4664748	R205.01	384772	4664778	30.8
R206	384802	4664761	R206.15	384781	4664782	30.8
R208	385349	4665237	R208.01	385349	4665267	33.5
R209	386615	4665626	R209.13	386585	4665626	32.5
R212	387160	4665631	R212.15	387139	4665653	29.8
R217	386217	4667306	R217.02	386228	4667333	36.1
R218	385049	4667225	R218.01	385049	4667255	33.3
R219	385000	4667233	R219.01	385000	4667263	33.2
R220	384989	4667245	R220.01	384989	4667275	33.3
R225	383812	4668484	R225.03	383833	4668505	34.8
R233	381314	4671326	R233.04	381342	4671337	36.7
R244	383560	4668904	R244.01	383560	4668934	35.1

Receptor ID	Centre of Building Receptor Location		Maximum Sound Level of Model Location			
	Easting [m]	Northing [m]	Model Receptor ID	Easting [m]	Northing [m]	Sound Level [dBA]
R250	379679	4667629	R250.03	379701	4667650	38.2
R251	379546	4668112	R251.04	379574	4668123	36.7
R252	380508	4669282	R252.07	380529	4669261	37.8
R254	381237	4669820	R254.08	381248	4669792	36.8
R267	378823	4671589	R267.04	378851	4671600	32.5
R320	375225	4669495	R320.01	375225	4669525	30.1
R323	376141	4669336	R323.01	376141	4669366	34.8
R329	377244	4670673	R329.10	377233	4670645	32.7
R450	376168	4670829	R450.07	376189	4670808	34.3
R495	378931	4677465	R495.06	378959	4677453	38.0
R562	380741	4662164	R562.01	380741	4662194	29.8
R565	378916	4663404	R565.02	378927	4663432	30.7
R569	379121	4663251	R569.02	379132	4663278	31.1
R624	379446	4662847	R624.01	379446	4662877	29.9
R625	379386	4662780	R625.02	379397	4662807	29.4
R628	379816	4663164	R628.02	379828	4663192	33.3
R635	381160	4662406	R635.01	381160	4662436	32.5
R636	381060	4662437	R636.01	381060	4662467	32.6
R637	381217	4662456	R637.01	381217	4662486	33.1
R638	381083	4662457	R638.01	381083	4662487	32.9
R639	381104	4662476	R639.01	381104	4662506	33.1
R641	381124	4662494	R641.01	381124	4662524	33.3
R643	381155	4662508	R643.01	381155	4662538	33.5
R645	381170	4662533	R645.01	381170	4662563	33.8
R647	381194	4662553	R647.01	381194	4662583	34.1
R650	381218	4662576	R650.01	381218	4662606	34.4
R652	381241	4662595	R652.01	381241	4662625	34.6
R660	381525	4662710	R660.01	381525	4662740	35.8
R672	379105	4662970	R672.02	379117	4662998	29.4
R675	379105	4662999	R675.02	379117	4663027	29.6
R677	379110	4663043	R677.01	379110	4663073	29.8
R680	379115	4663092	R680.01	379115	4663122	30.1
R681	379858	4663114	R681.02	379870	4663142	33.0
R685	379115	4663142	R685.02	379127	4663169	30.4
R687	379118	4663200	R687.01	379118	4663230	30.7
R688	379122	4663221	R688.02	379133	4663248	30.9
R691	379115	4663332	R691.02	379126	4663360	31.5
R701	381239	4664324	R701.05	381269	4664324	37.9
R704	379436	4664587	R704.06	379464	4664575	38.2
R720	376704	4669425	R720.01	376704	4669455	36.7

Receptor ID	Centre of Building Receptor Location		Maximum Sound Level of Model Location			
	Easting [m]	Northing [m]	Model Receptor ID	Easting [m]	Northing [m]	Sound Level [dBA]
R819	379714	4671914	R819.07	379735	4671892	36.5
R821	385515	4666841	R821.07	385536	4666820	35.2
R825	385478	4664625	R825.01	385478	4664655	29.5
R997	378952	4678823	R997.10	378940	4678796	36.2
R2035	378268	4678809	R2035.10	378256	4678782	38.8
R2036	378391	4678895	R2036.10	378379	4678867	37.1
R2039	378544	4678774	R2039.10	378532	4678747	37.4
R2086	380518	4663666	R2086.01	380518	4663696	37.1
R2088	379552	4662837	R2088.01	379552	4662867	30.2
R2089	379420	4662827	R2089.01	379420	4662857	29.7
R2091	379104	4662986	R2091.01	379104	4663016	29.4
R2096	379960	4666842	R2096.07	379981	4666821	37.5
R2097	380673	4669453	R2097.05	380703	4669453	37.8
R2099	380070	4668796	R2099.05	380100	4668796	36.4
R2143	380784	4662202	R2143.01	380784	4662232	30.1
R2144	381270	4662605	R2144.01	381270	4662635	34.8
R2146	382178	4662971	R2146.13	382148	4662972	34.0
R2153	385556	4664679	R2153.01	385556	4664709	29.7
R2154	385624	4664695	R2154.01	385624	4664725	29.8
R5016	382490	4664539	R5016.02	382501	4664567	38.3
R5564	382250	4663308	R5564.14	382222	4663319	35.7
R6178	382089	4662888	R6178.15	382068	4662909	34.1

APPENDIX B – COORDINATES OF PARTICIPANTS

Coordinates of all modeled participants for the Project (UTM17-NAD83 projection) are given in the table below.

Participant ID	Parcel Identification Number	Easting [m]	Northing [m]	Base Elevation [m]
R16	008310003	380395	4667324	186
R17	008310023	381665	4666607	185
R21	008340028	382439	4664629	190
R26	008480104	386270	4665476	190
R30	008310015	382129	4668851	190
R32	008310058	381726	4668401	189
R33	008310072	379865	4668610	185
R35	008300020	381194	4669911	185
R36	008300018	380313	4670845	187
R165	008340014	382502	4667255	187
R168	008330045	379878	4664938	188
R181	008470037	380790	4663908	187
R188	008470038	381639	4662918	188
R193	008470050	382328	4663524	190
R448	750810055	376441	4669408	186
R2083	008340041	383694	4666457	195
R2098	008310007	380508	4669179	187
V5487	008310021	380699	4667466	187
V5495	008300002	380245	4670927	190
V5497	008330039	379693	4664773	185
V5535	008310012	381770	4668565	189
V5539	008310009	381426	4668254	189
V5494	008300001	379720	4670434	185
V5581	750770075	379248	4678254	184
V6116	008310058	382198	4668793	190



APPENDIX C – NOISE ISO-CONTOUR MAPS

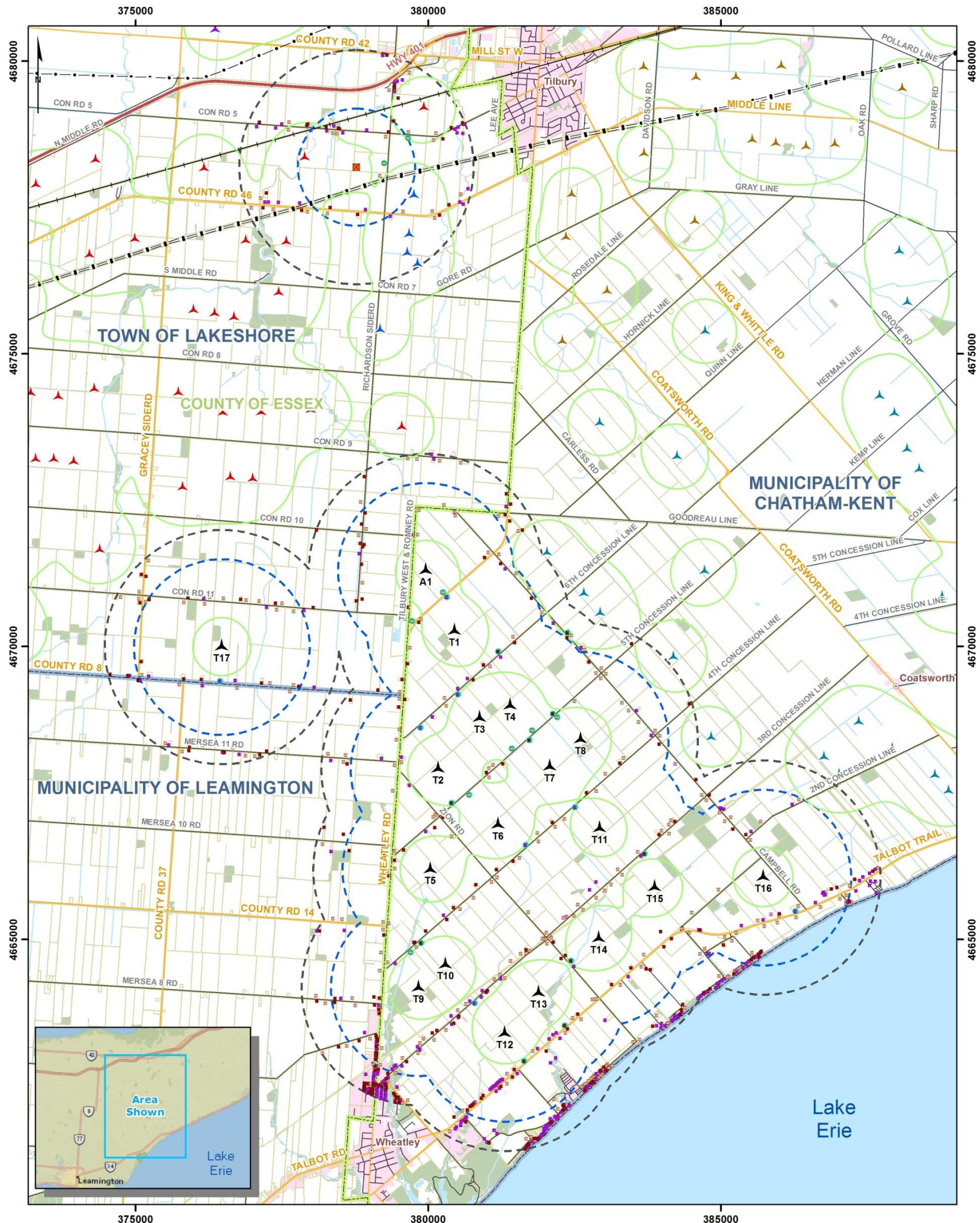

Legend			
Project Features	Existing Projects	Other Components	Other Components
▲ Wind turbine (18)	Neighbouring wind farm	3 Story Receptor	— Railroad
■ Substation	▲ Chatham-Kent Wind Farm	2 Story Receptor	Waterbody
▭ Noise Assessment Area	▲ Comber Wind Farm	1 Story Receptor	Wooded area
▭ Investigation Area (2 km)	▲ Gracey Wind Farm	Vacant Lot Receptor	Built-up area
	▲ Pointe-aux-Roches Wind Farm	○ POR on Participating Lot	Property Boundary
	▲ Port Alma Wind Farm	— Watercourse	County Boundary
	▲ Richardson Wind Farm	— Existing HONI Transmission Line	Municipal Boundary
	▲ South Kent Wind	— Highway	
		— Arterial / Collector	
		— Local Road / Street	
			Predicted Sound Level
			Worst Case Wind Speed
			40 dB(A) at 4.5 m agl*
			*agl: above ground level

ROMNEY
wind energy centre

SIMULATED SOUND ISOCOUNTOUR
[WIND SPEED OF 6 m/s]

10021083-171012-001-LB
October 12, 2017
Projection: UTM Zone 17, NAD83

DNV·GL

Source: Land Information Ontario, ArcGIS Online, Teranet, Callon Dietz.

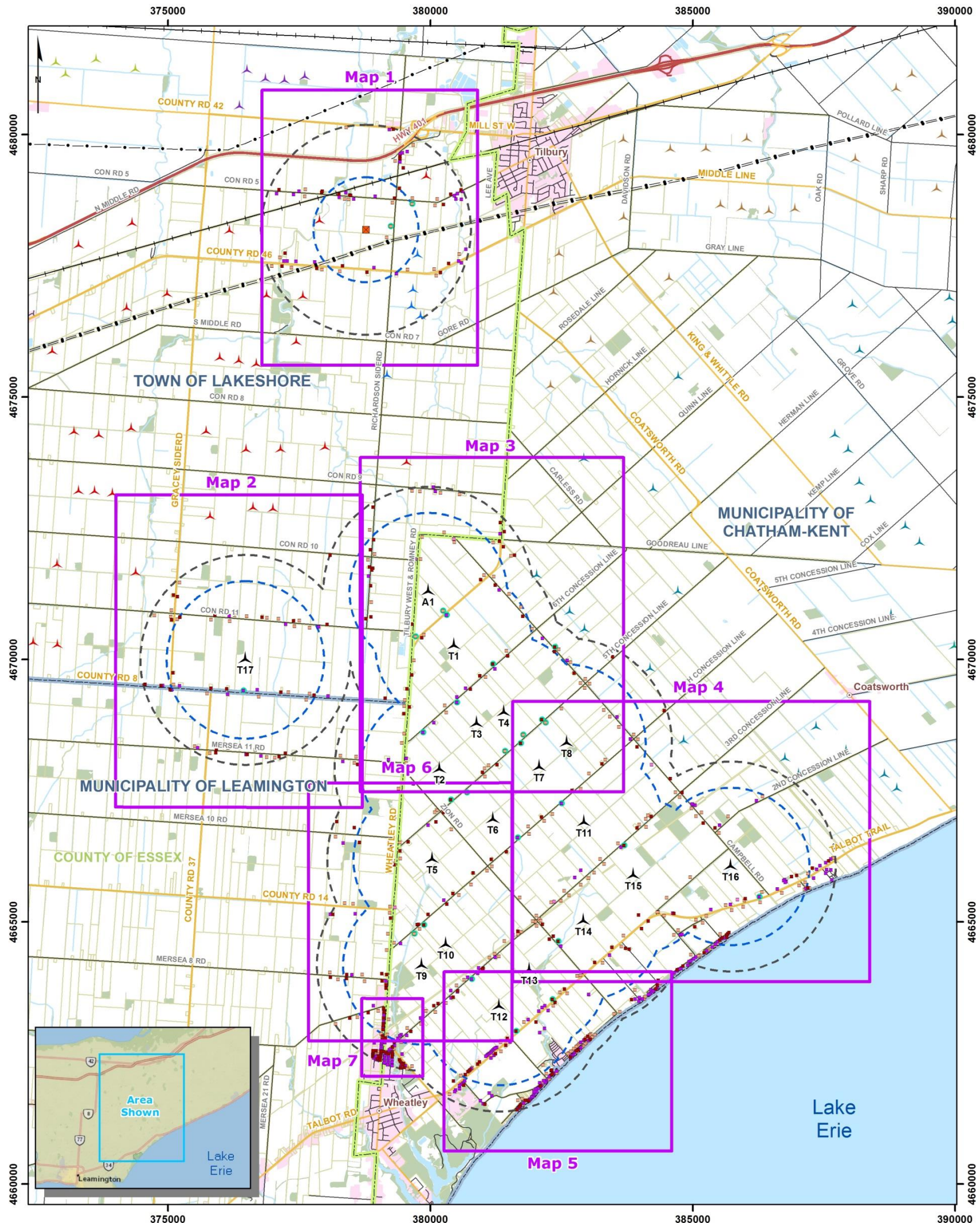

Legend			
Project Features	Existing Projects	Other Components	
Wind turbine (18)	Neighbouring wind farm	3 Storey Receptor	Railroad
Substation	Chatham-Kent Wind Farm	2 Storey Receptor	Waterbody
Noise Assessment Area	Comber Wind Farm	1 Storey Receptor	Wooded area
Investigation Area (2 km)	Gracey Wind Farm	Vacant Lot Receptor	Built-up area
	Pointe-aux-Roches Wind Farm	POR on Participating Lot	Property Boundary
	Port Alma Wind Farm	Watercourse	County Boundary
	Richardson Wind Farm	Existing HONI Transmission Line	Municipal Boundary
	South Kent Wind	Highway	
		Arterial / Collector	
		Local Road / Street	





ROMNEY
wind energy centre

NOISE MAP EXTENTS

10021083-171012-001-LB
October 12, 2017
Layout 68
Projection: UTM Zone 17, NAD83

DNV·GL

Source: Land Information Ontario, ArcGIS Online, Teranet, Callon Dietz.

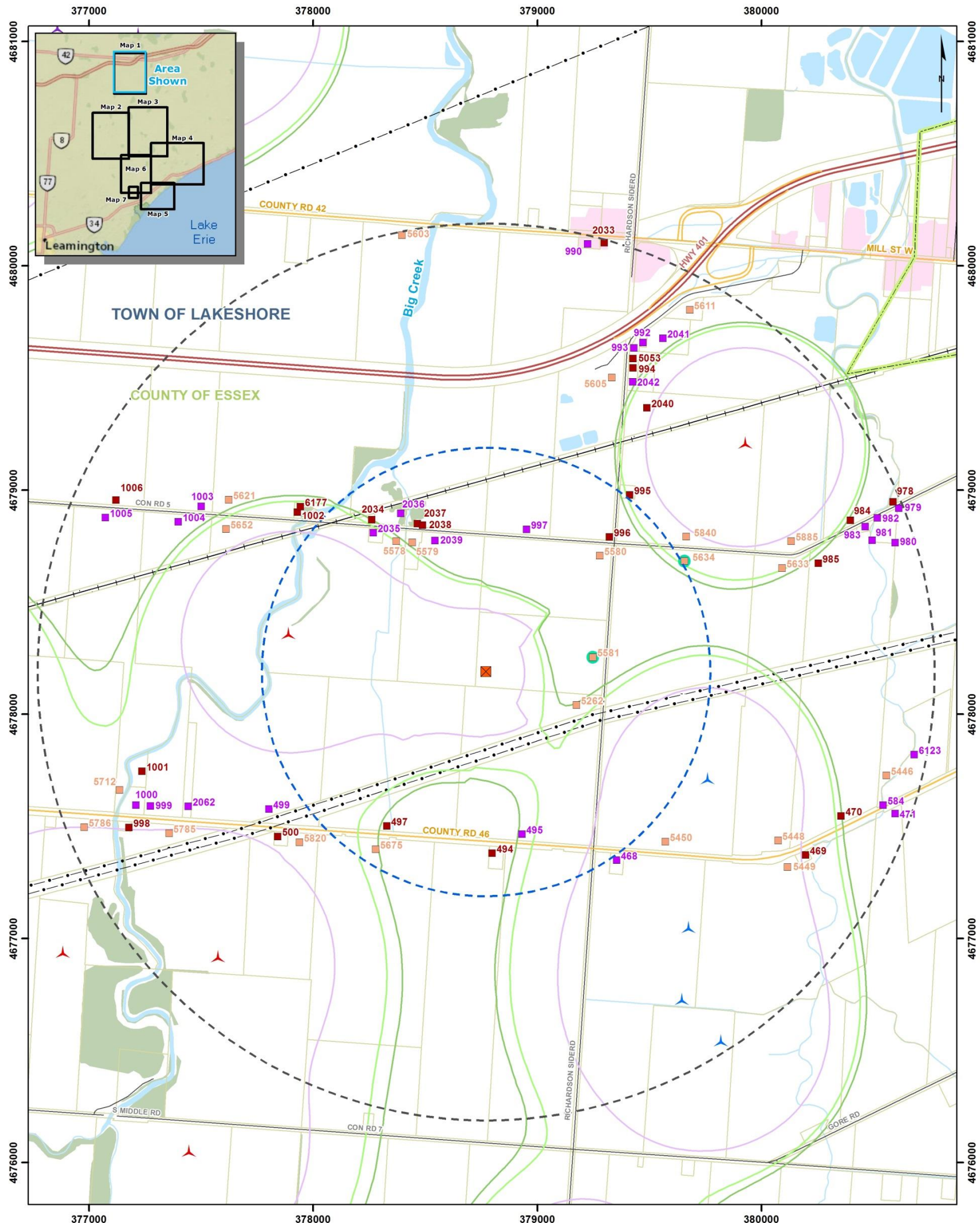

Legend

<p>Project Features</p> <ul style="list-style-type: none"> Wind turbine (18) Substation 1 km Buffer from Project Transformer Investigation Area (2 km) 	<p>Existing Projects</p> <ul style="list-style-type: none"> Neighbouring wind farm Chatham-Kent Wind Farm Comber Wind Farm Gracey Wind Farm Pointe-aux-Roches Wind Farm Port Alma Wind Farm Richardson Wind Farm South Kent Wind 	<p>Other Components</p> <ul style="list-style-type: none"> 3 Storey Receptor 2 Storey Receptor 1 Storey Receptor Vacant Lot Receptor POR on Participating Lot Watercourse Existing HONI Transmission Line Highway Arterial / Collector Local Road / Street Railroad 	<ul style="list-style-type: none"> Waterbody Wooded area Built-up area Property Boundary County Boundary Municipal Boundary <p>Predicted Sound Level Worst Case Wind Speed</p> <ul style="list-style-type: none"> 40 dB(A) at 7.5 m agl* 40 dB(A) at 4.5 m agl* 40 dB(A) at 1.5 m agl* <p>*agl: above ground level</p>
---	---	---	--

0 250 500 Meters

ROMNEY
wind energy centre

SIMULATED SOUND ISOCONTOUR LEVELS
[WIND SPEED OF 6 m/s]
Map 1A

10021083-171012-001-LB
October 12, 2017
Layout 68
Projection: UTM Zone 17, NAD83

DNV·GL

Source: Land Information Ontario, ArcGIS Online, Teranet, Callon Dietz

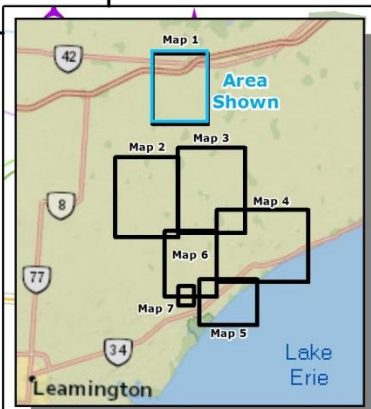
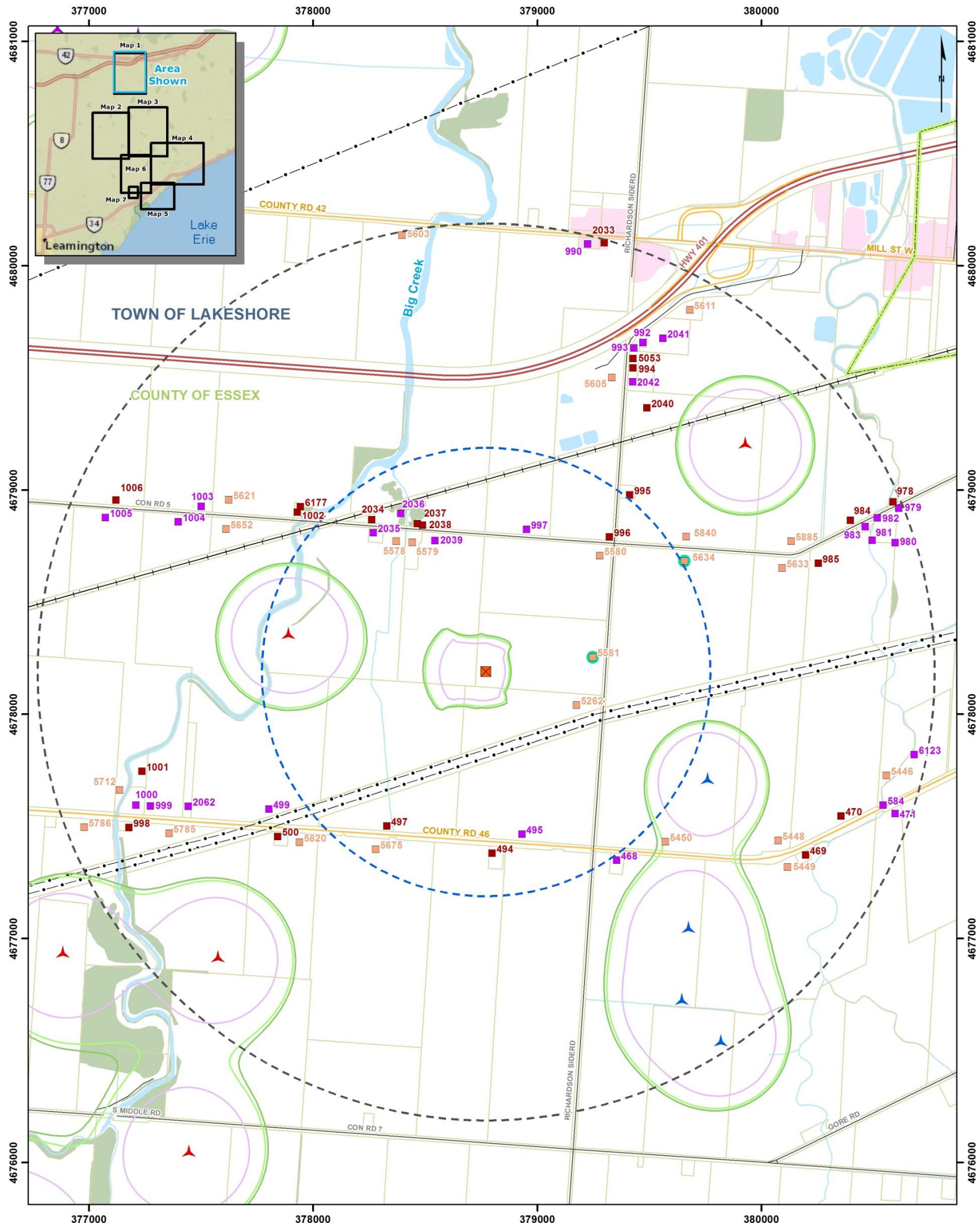

Legend			
Project Features	Existing Projects	Other Components	Waterbody
▲ Wind turbine (18)	Neighbouring wind farm	■ 3 Storey Receptor	■ Wooded area
■ Substation	▲ Chatham-Kent Wind Farm	■ 2 Storey Receptor	■ Built-up area
■ 1 km Buffer from Project Transformer	▲ Comber Wind Farm	■ 1 Storey Receptor	■ Property Boundary
■ Investigation Area (2 km)	▲ Gracey Wind Farm	■ Vacant Lot Receptor	■ County Boundary
	▲ Pointe-aux-Roches Wind Farm	○ POR on Participating Lot	■ Municipal Boundary
	▲ Port Alma Wind Farm	— Watercourse	
	▲ Richardson Wind Farm	— Existing HONI Transmission Line	
	▲ South Kent Wind	— Highway	
		— Arterial / Collector	
		— Local Road / Street	
		— Railroad	
			Predicted Sound Level Worst Case Wind Speed
			— 45 dB(A) at 7.5 m agl*
			— 45 dB(A) at 4.5 m agl*
			— 45 dB(A) at 1.5 m agl*
			*agl: above ground level

ROMNEY
wind energy centre

SIMULATED SOUND ISOCONTOUR LEVELS
[WIND SPEED OF 8 m/s]
Map 1B

10021083-171012-001-LB
October 12, 2017
Layout 68
Projection: UTM Zone 17, NAD83

DNV·GL

Source: Land Information Ontario, ArcGIS Online, Teranet, Callon Dietz.

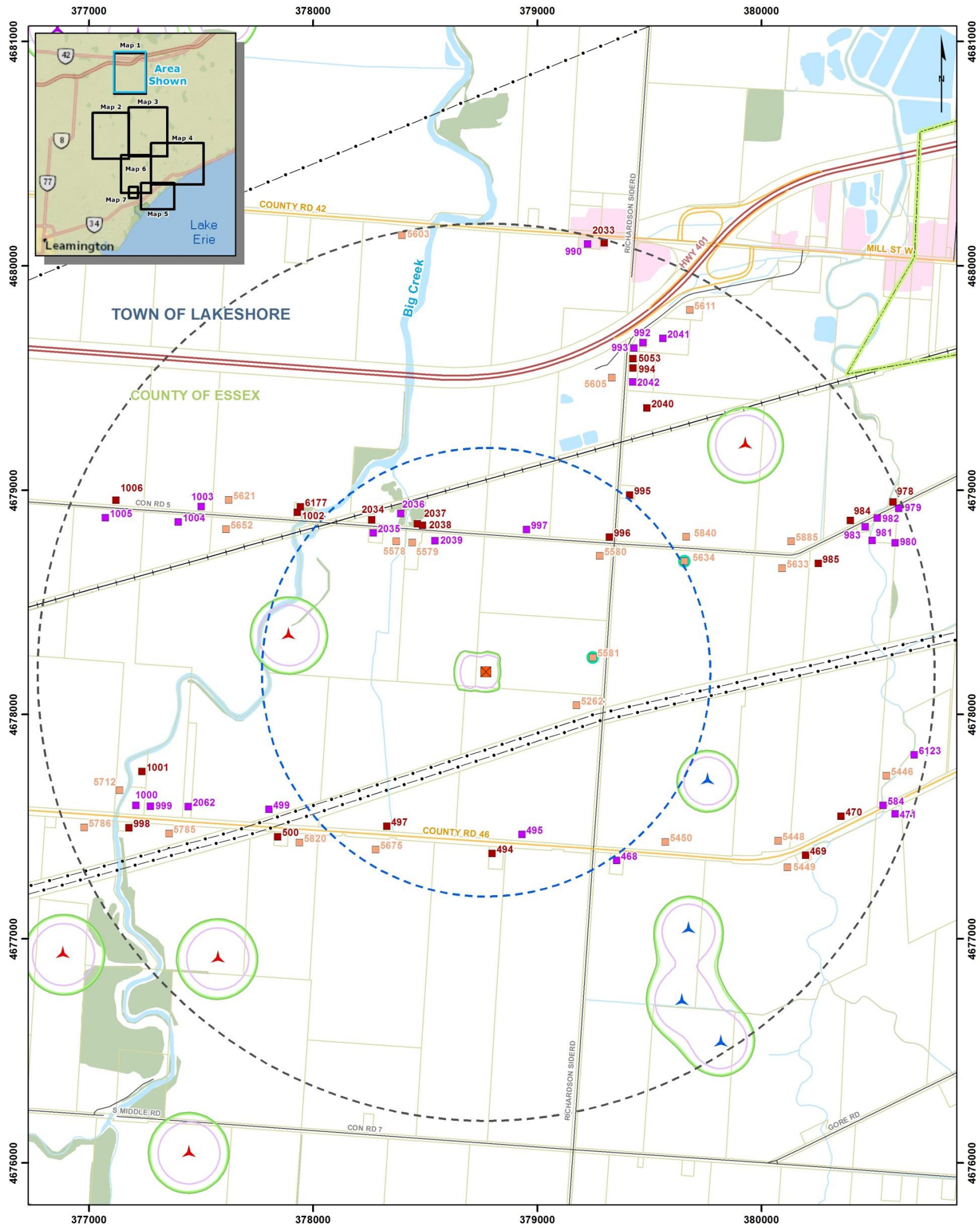

Legend

<p>Project Features</p> <ul style="list-style-type: none"> ▲ Wind turbine (18) ■ Substation □ 1 km Buffer from Project Transformer □ Investigation Area (2 km) 	<p>Existing Projects</p> <ul style="list-style-type: none"> ▲ Neighbouring wind farm ▲ Chatham-Kent Wind Farm ▲ Comber Wind Farm ▲ Gracey Wind Farm ▲ Pointe-aux-Roches Wind Farm ▲ Port Alma Wind Farm ▲ Richardson Wind Farm ▲ South Kent Wind 	<p>Other Components</p> <ul style="list-style-type: none"> ■ 3 Storey Receptor ■ 2 Storey Receptor ■ 1 Storey Receptor ■ Vacant Lot Receptor ○ POR on Participating Lot — Watercourse — Existing HONI Transmission Line — Highway — Arterial / Collector — Local Road / Street — Railroad 	<ul style="list-style-type: none"> — Waterbody — Wooded area — Built-up area — Property Boundary — County Boundary — Municipal Boundary <p>Predicted Sound Level Worst Case Wind Speed</p> <ul style="list-style-type: none"> — 50 dB(A) at 7.5 m agl* — 50 dB(A) at 4.5 m agl* — 50 dB(A) at 1.5 m agl* <p>*agl: above ground level</p>
---	---	---	--

0 250 500 Meters

ROMNEY
wind energy centre

SIMULATED SOUND ISOCONTOUR LEVELS
[WIND SPEED OF 10 m/s]
Map 1C

DNV-GL

10021083-171012-001-LB
October 12, 2017
Layout 68
Projection: UTM Zone 17, NAD83

Source: Land Information Ontario, ArcGIS Online, Teranet, Callon Dietz.

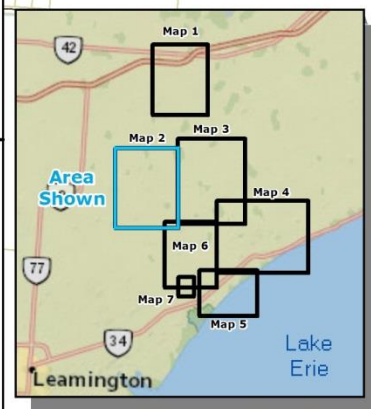
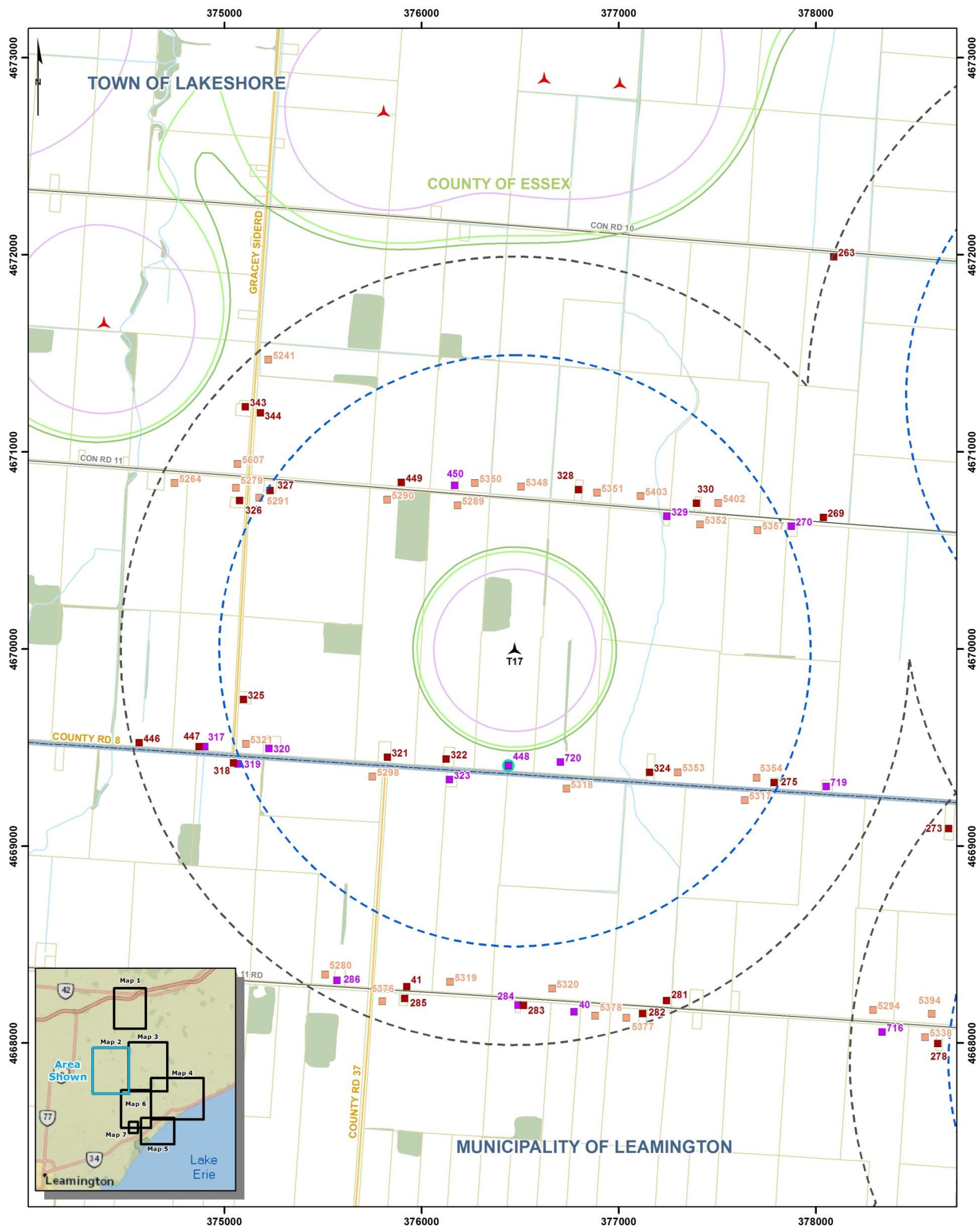

Legend			
Project Features	Existing Projects	Other Components	Predicted Sound Level Worst Case Wind Speed
▲ Wind turbine (18)	Neighbouring wind farm	■ 3 Storey Receptor	40 dB(A) at 7.5 m agl*
■ Substation	▲ Chatham-Kent Wind Farm	■ 2 Storey Receptor	40 dB(A) at 4.5 m agl*
■ 1.5 km Buffer from Project Noise Sources	▲ Comber Wind Farm	■ 1 Storey Receptor	40 dB(A) at 1.5 m agl*
■ Investigation Area (2 km)	▲ Gracey Wind Farm	■ Vacant Lot Receptor	
	▲ Pointe-aux-Roches Wind Farm	○ POR on Participating Lot	
	▲ Port Alma Wind Farm	— Watercourse	
	▲ Richardson Wind Farm	— Existing HONI Transmission Line	
	▲ South Kent Wind	— Highway	
		— Arterial / Collector	
		— Local Road / Street	
		— Railroad	
		— Waterbody	
		— Wooded area	
		— Built-up area	
		— Property Boundary	
		— County Boundary	
		— Municipal Boundary	



ROMNEY
wind energy centre

SIMULATED SOUND ISOCONTOUR LEVELS
[WIND SPEED OF 6 m/s]
Map 2A

10021083-1701012-001-LB
October 12, 2017
Layout 68
Projection: UTM Zone 17, NAD83

Source: Land Information Ontario, ArcGIS Online, Teranet, Callon Dietz.

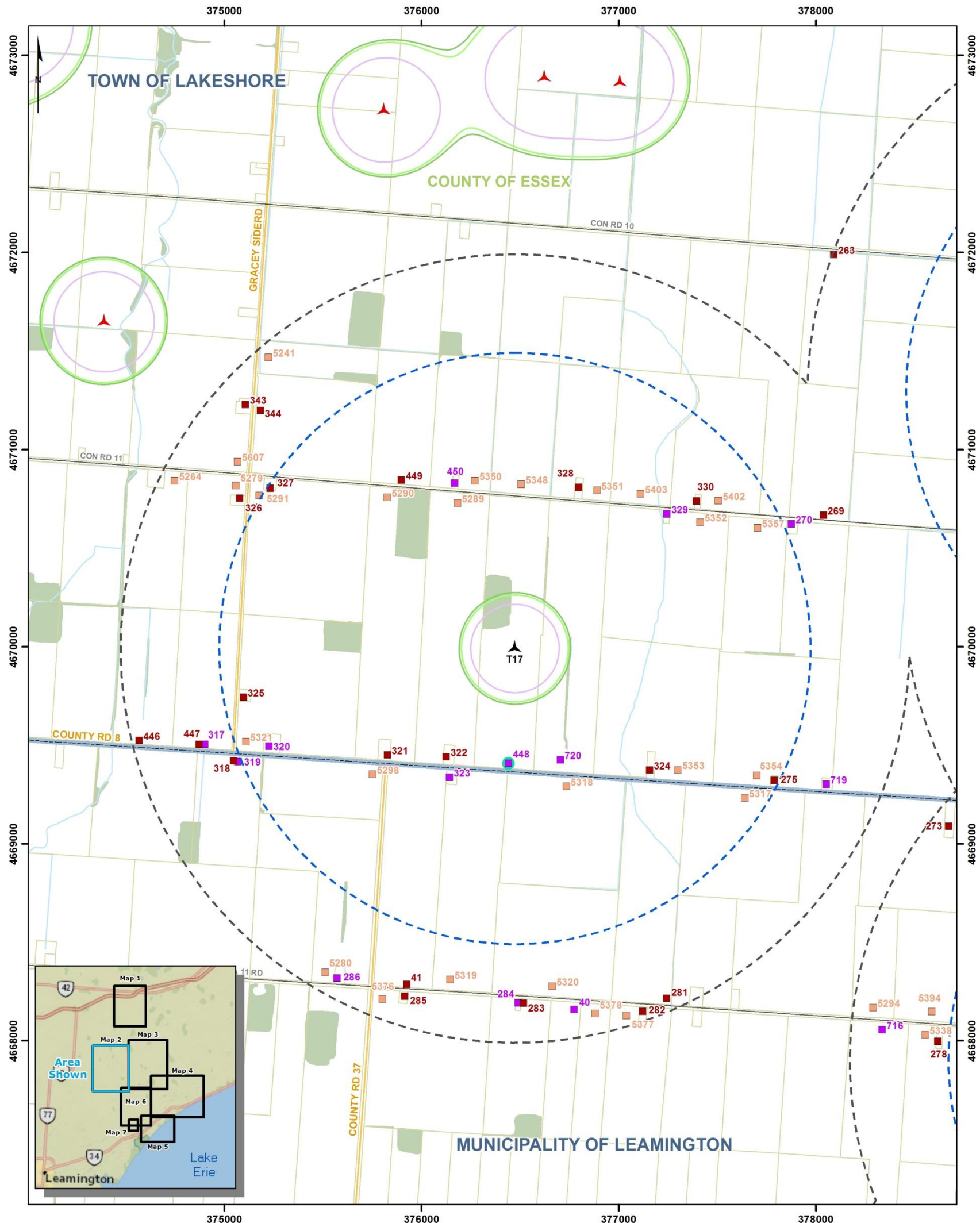

Legend

<p>Project Features</p> <ul style="list-style-type: none"> ▲ Wind turbine (18) ■ Substation □ 1.5 km Buffer from Project Noise Sources □ Investigation Area (2 km) 	<p>Existing Projects</p> <p>Neighbouring wind farm</p> <ul style="list-style-type: none"> ▲ Chatham-Kent Wind Farm ▲ Comber Wind Farm ▲ Gracey Wind Farm ▲ Pointe-aux-Roches Wind Farm ▲ Port Alma Wind Farm ▲ Richardson Wind Farm ▲ South Kent Wind 	<p>Other Components</p> <ul style="list-style-type: none"> ■ 3 Storey Receptor ■ 2 Storey Receptor ■ 1 Storey Receptor ■ Vacant Lot Receptor ○ POR on Participating Lot — Watercourse — Existing HONI Transmission Line — Highway — Arterial / Collector — Local Road / Street — Railroad 	<ul style="list-style-type: none"> — Waterbody — Wooded area — Built-up area — Property Boundary — County Boundary — Municipal Boundary <p>Predicted Sound Level Worst Case Wind Speed</p> <ul style="list-style-type: none"> — 45 dB(A) at 7.5 m agl* — 45 dB(A) at 4.5 m agl* — 45 dB(A) at 1.5 m agl* <p>*agl: above ground level</p>
---	---	---	--

0 250 500 Meters

ROMNEY
wind energy centre

SIMULATED SOUND ISOCONTOUR LEVELS
[WIND SPEED OF 8 m/s]
Map 2B

10021083-171012-001-LB
October 12, 2017
Layout 68
Projection: UTM Zone 17, NAD83

DNV·GL

Source: Land Information Ontario, ArcGIS Online, Teranet, Callon Dietz.

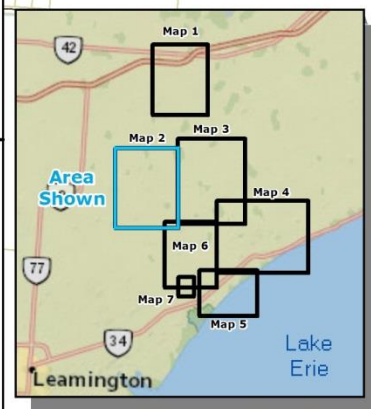
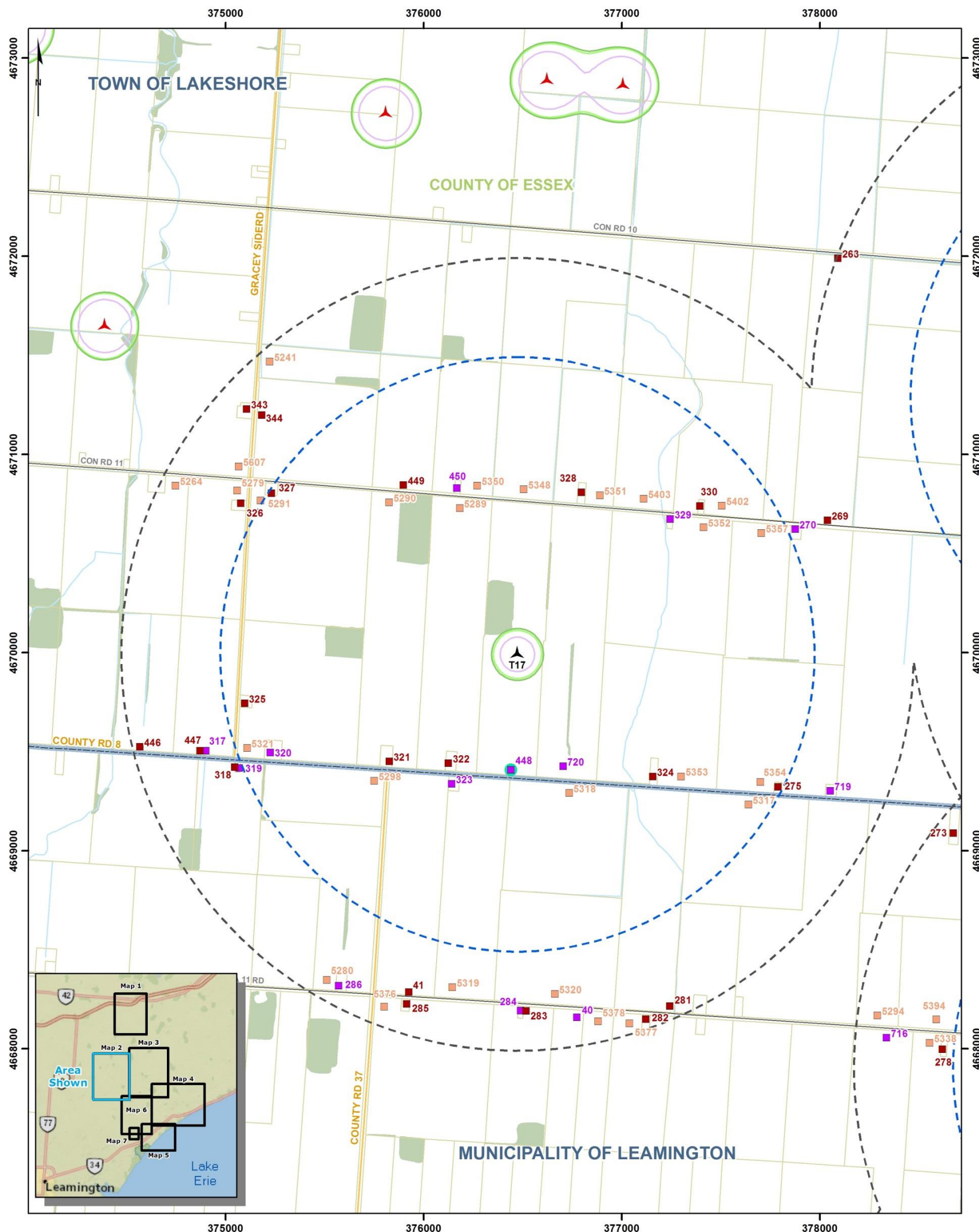

Legend

<p>Project Features</p> <ul style="list-style-type: none"> ▲ Wind turbine (18) ■ Substation □ 1.5 km Buffer from Project Noise Sources □ Investigation Area (2 km) 	<p>Existing Projects</p> <p>Neighbouring wind farm</p> <ul style="list-style-type: none"> ▲ Chatham-Kent Wind Farm ▲ Comber Wind Farm ▲ Gracey Wind Farm ▲ Pointe-aux-Roches Wind Farm ▲ Port Alma Wind Farm ▲ Richardson Wind Farm ▲ South Kent Wind 	<p>Other Components</p> <ul style="list-style-type: none"> ■ 3 Storey Receptor ■ 2 Storey Receptor ■ 1 Storey Receptor ■ Vacant Lot Receptor ○ POR on Participating Lot — Watercourse — Existing HONI Transmission Line — Highway — Arterial / Collector — Local Road / Street — Railroad 	<ul style="list-style-type: none"> — Waterbody — Wooded area — Built-up area — Property Boundary — County Boundary — Municipal Boundary <p>Predicted Sound Level Worst Case Wind Speed</p> <ul style="list-style-type: none"> — 50 dB(A) at 7.5 m agl* — 50 dB(A) at 4.5 m agl* — 50 dB(A) at 1.5 m agl* *agl: above ground level
---	---	---	--

0 250 500 Meters

ROMNEY
wind energy centre

SIMULATED SOUND ISOCONTOUR LEVELS
[WIND SPEED OF 10 m/s]
Map 2C

10021083-171012-001-LB
October 12, 2017
Layout 68
Projection: UTM Zone 17, NAD83

DNV·GL

Source: Land Information Ontario, ArcGIS Online, Teranet, Callon Dietz.

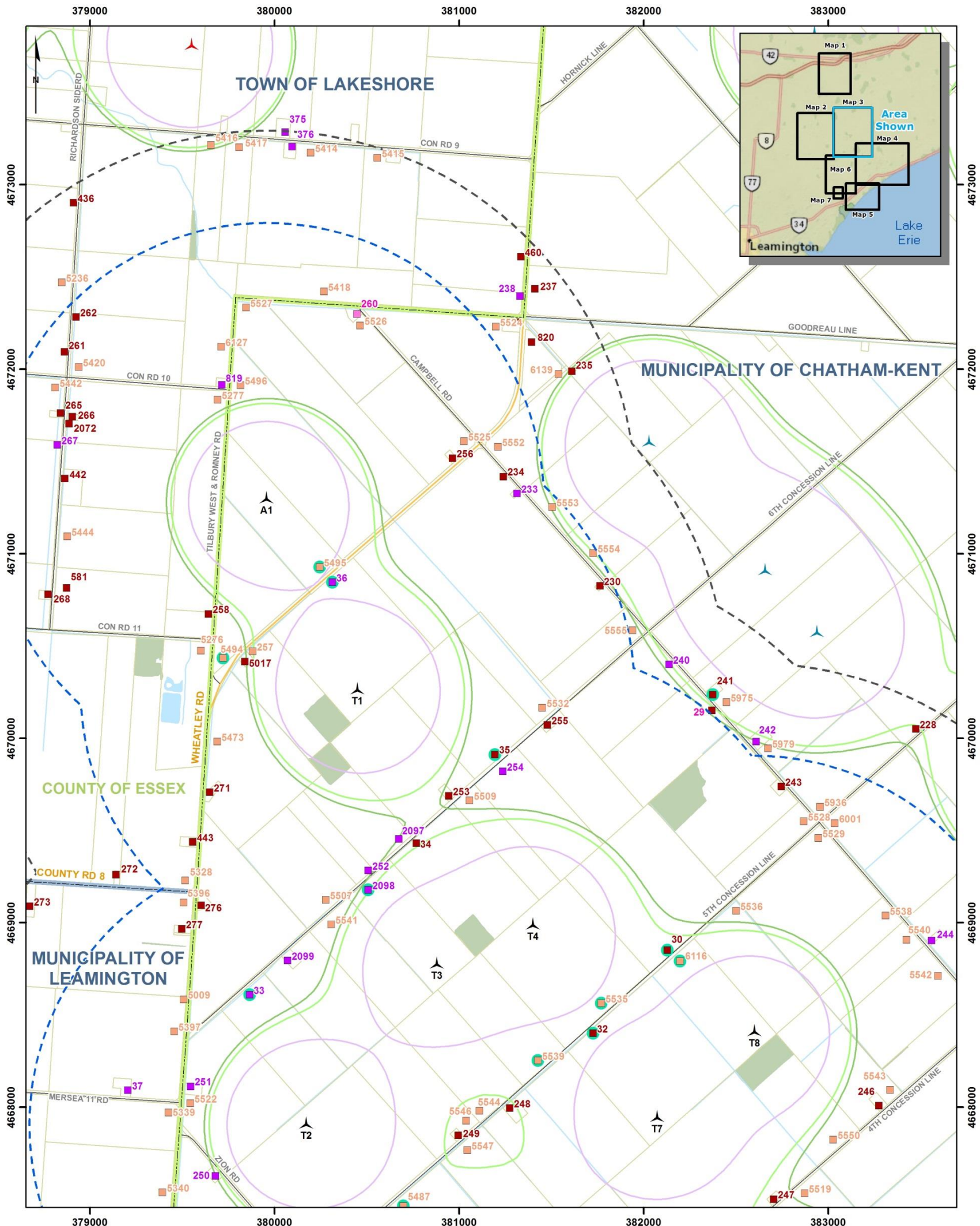

Legend

<p>Project Features</p> <ul style="list-style-type: none"> Wind turbine (18) Substation 1.5 km Buffer from Project Noise Sources Investigation Area (2 km) 	<p>Existing Projects</p> <ul style="list-style-type: none"> Neighbouring wind farm Chatham-Kent Wind Farm Comber Wind Farm Gracey Wind Farm Pointe-aux-Roches Wind Farm Port Alma Wind Farm Richardson Wind Farm South Kent Wind 	<p>Other Components</p> <ul style="list-style-type: none"> 3 Storey Receptor 2 Storey Receptor 1 Storey Receptor Vacant Lot Receptor POR on Participating Lot Watercourse Existing HONI Transmission Line Highway Arterial / Collector Local Road / Street Railroad 	<ul style="list-style-type: none"> Waterbody Wooded area Built-up area Property Boundary County Boundary Municipal Boundary <p>Predicted Sound Level Worst Case Wind Speed</p> <ul style="list-style-type: none"> 40 dB(A) at 7.5 m agl* 40 dB(A) at 4.5 m agl* 40 dB(A) at 1.5 m agl* <p>*agl: above ground level</p>
---	---	---	--

0 250 500 Meters

SIMULATED SOUND ISOCONTOUR LEVELS
[WIND SPEED OF 6 m/s]
Map 3A

10021083-171012-001-LB
October 12, 2017
Layout 68
Projection: UTM Zone 17, NAD83

DNV·GL

Source: Land Information Ontario, ArcGIS Online, Teranet, Callon Dietz.

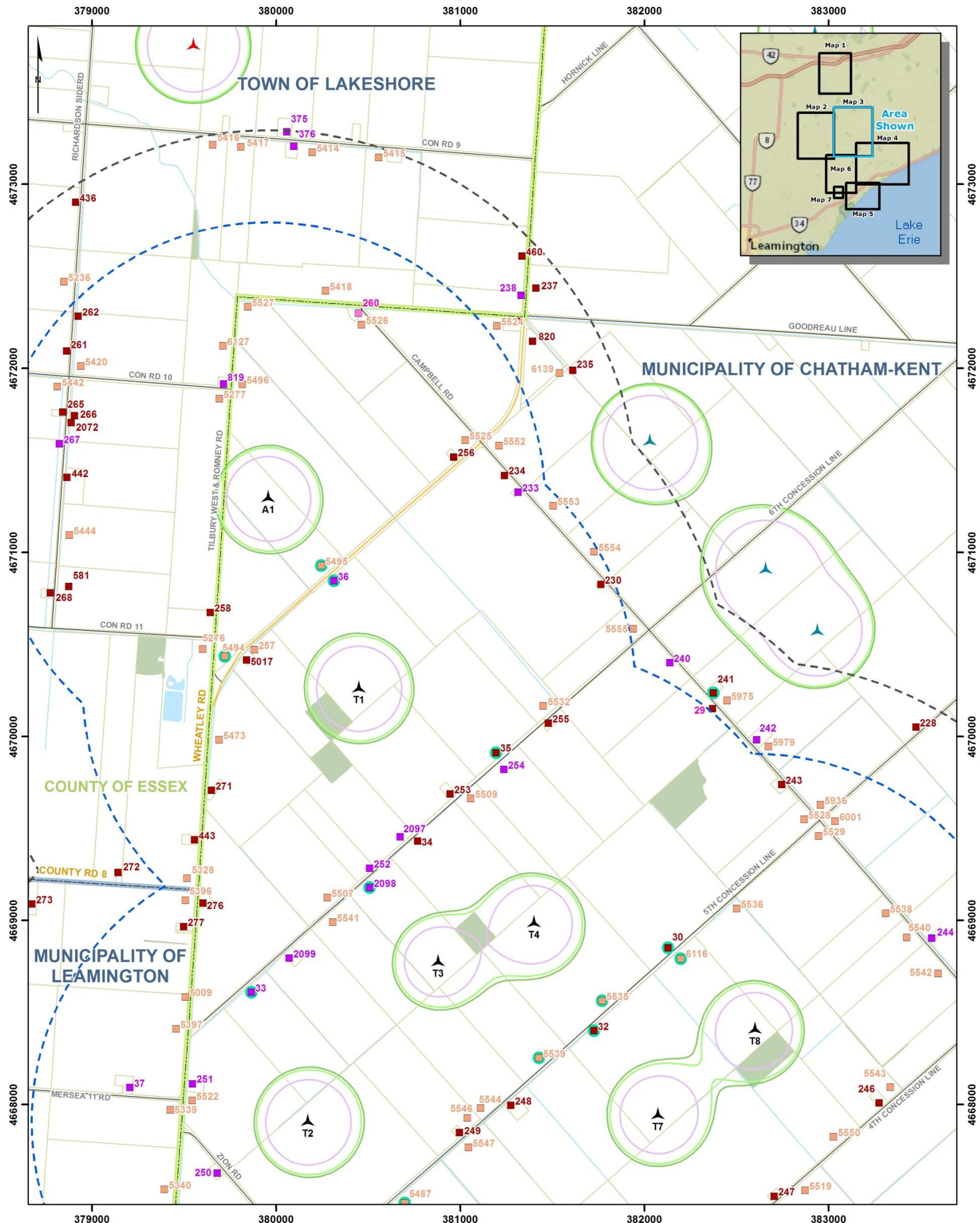

Legend

<p>Project Features</p> <ul style="list-style-type: none"> ▲ Wind turbine (18) ■ Substation — 1.5 km Buffer from Project Noise Sources □ Investigation Area (2 km) 	<p>Existing Projects</p> <ul style="list-style-type: none"> ▲ Neighbouring wind farm ▲ Chatham-Kent Wind Farm ▲ Comber Wind Farm ▲ Gracey Wind Farm ▲ Pointe-aux-Roches Wind Farm ▲ Port Alma Wind Farm ▲ Richardson Wind Farm ▲ South Kent Wind 	<p>Other Components</p> <ul style="list-style-type: none"> ■ 3 Storey Receptor ■ 2 Storey Receptor ■ 1 Storey Receptor ■ Vacant Lot Receptor ○ POR on Participating Lot — Watercourse — Existing HONI Transmission Line — Highway — Arterial / Collector — Local Road / Street — Railroad 	<ul style="list-style-type: none"> — Waterbody — Wooded area — Built-up area — Property Boundary — County Boundary — Municipal Boundary <p>Predicted Sound Level Worst Case Wind Speed</p> <ul style="list-style-type: none"> — 45 dB(A) at 7.5 m agl* — 45 dB(A) at 4.5 m agl* — 45 dB(A) at 1.5 m agl* <p>*agl: above ground level</p>
---	---	---	--

0 250 500 Meters

ROMNEY
wind energy centre

SIMULATED SOUND ISOCONTOUR LEVELS
[WIND SPEED OF 8 m/s]
Map 3B

10021083-171012-001-LB
October 12, 2017
Layout 68
Projection: UTM Zone 17, NAD83

DNV·GL

Source: Land Information Ontario, ArcGIS Online, Teranet, Callon Dietz.

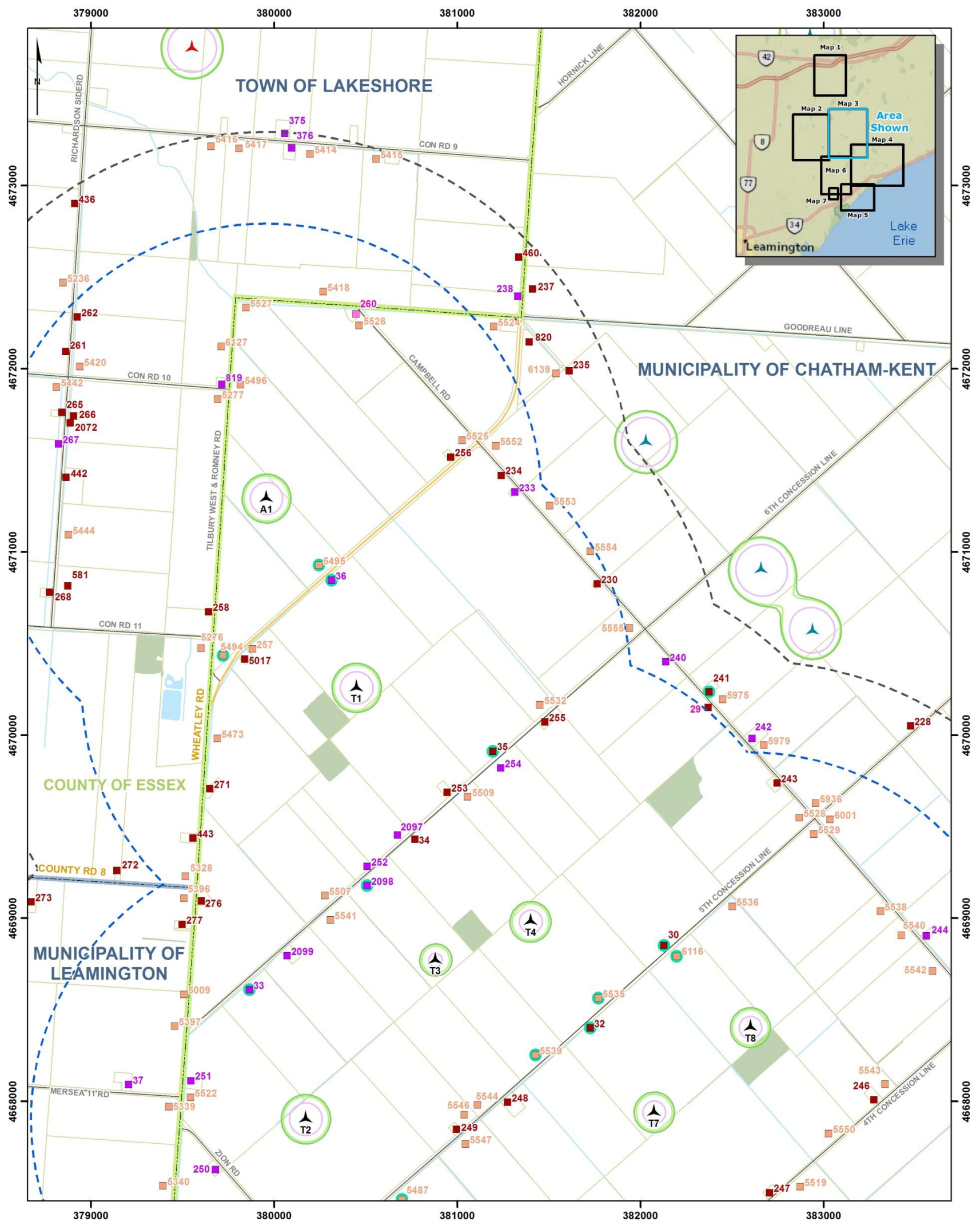

Legend

<p>Project Features</p> <ul style="list-style-type: none"> ▲ Wind turbine (18) ■ Substation □ 1.5 km Buffer from Project Noise Sources □ Investigation Area (2 km) 	<p>Existing Projects</p> <ul style="list-style-type: none"> ▲ Neighbouring wind farm ▲ Chatham-Kent Wind Farm ▲ Comber Wind Farm ▲ Gracey Wind Farm ▲ Pointe-aux-Roches Wind Farm ▲ Port Alma Wind Farm ▲ Richardson Wind Farm ▲ South Kent Wind 	<p>Other Components</p> <ul style="list-style-type: none"> ■ 3 Storey Receptor ■ 2 Storey Receptor ■ 1 Storey Receptor ■ Vacant Lot Receptor ○ POR on Participating Lot — Watercourse — Existing HONI Transmission Line — Highway — Arterial / Collector — Local Road / Street — Railroad 	<ul style="list-style-type: none"> ■ Waterbody ■ Wooded area ■ Built-up area ■ Property Boundary ■ County Boundary ■ Municipal Boundary <p>Predicted Sound Level Worst Case Wind Speed</p> <ul style="list-style-type: none"> — 50 dB(A) at 7.5 m agl* — 50 dB(A) at 4.5 m agl* — 50 dB(A) at 1.5 m agl* <p>*agl: above ground level</p>
---	---	---	--

0 250 500 Meters

ROMNEY
wind energy centre

SIMULATED SOUND ISOCONTOUR LEVELS
[WIND SPEED OF 10 m/s]
Map 3C

10021083-171012-001-LB
October 12, 2017
Layout 68
Projection: UTM Zone 17, NAD83

DNV·GL

Source: Land Information Ontario, ArcGIS Online, Teranet, Callon Dietz.

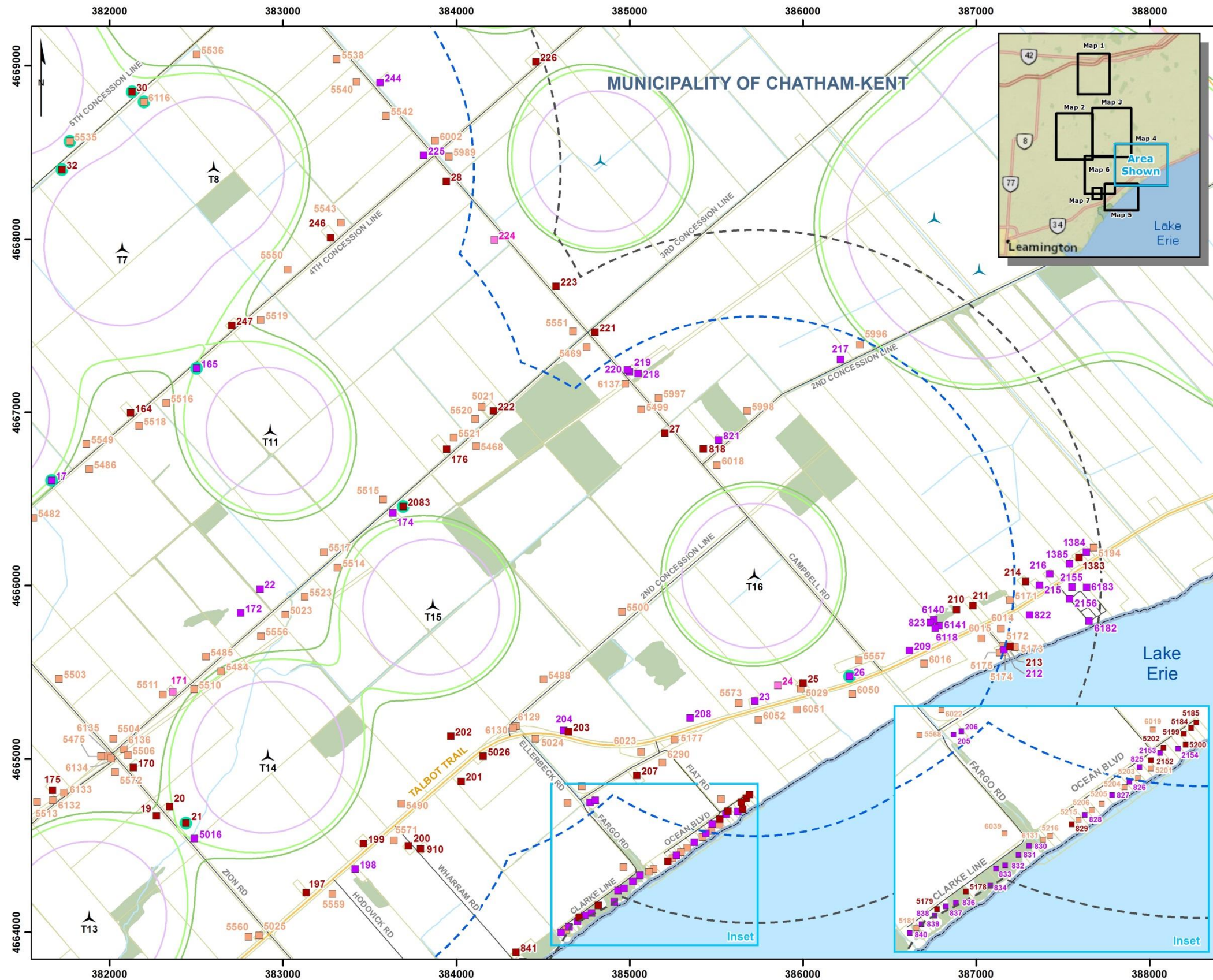

Legend

Project Features	Other Components
▲ Wind turbine (18)	■ 3 Storey Receptor
■ Substation	■ 2 Storey Receptor
■ 1.5 km Buffer from Project Noise Sources	■ 1 Storey Receptor
■ Investigation Area (2 km)	■ Vacant Lot Receptor
	○ POR on Participating Lot
Existing Projects	— Watercourse
Neighbouring wind farm	— Existing HONI
▲ Chatham-Kent Wind Farm	— Transmission Line
▲ Comber Wind Farm	— Highway
▲ Gracey Wind Farm	— Arterial / Collector
▲ Pointe-aux-Roches Wind Farm	— Local Road / Street
▲ Port Alma Wind Farm	— Railroad
▲ Richardson Wind Farm	— Waterbody
▲ South Kent Wind	— Wooded area
	— Built-up area
	— Property Boundary
	— County Boundary
	— Municipal Boundary

Predicted Sound Level Worst Case Wind Speed

- 40 dB(A) at 7.5 m agl*
- 40 dB(A) at 4.5 m agl*
- 40 dB(A) at 1.5 m agl*

*agl: above ground level

0 250 500 Meters

ROMNEY
wind energy centre

SIMULATED SOUND ISOCONTOUR LEVELS
[WIND SPEED OF 6 m/s]
Map 4A

10021083-171012-001-LB
October 12, 2017
Layout 88

DNV·GL

Projection: UTM Zone 17, NAD83
Source: Land Information Ontario, ArcGIS Online, Teranet, Callon Dietz.

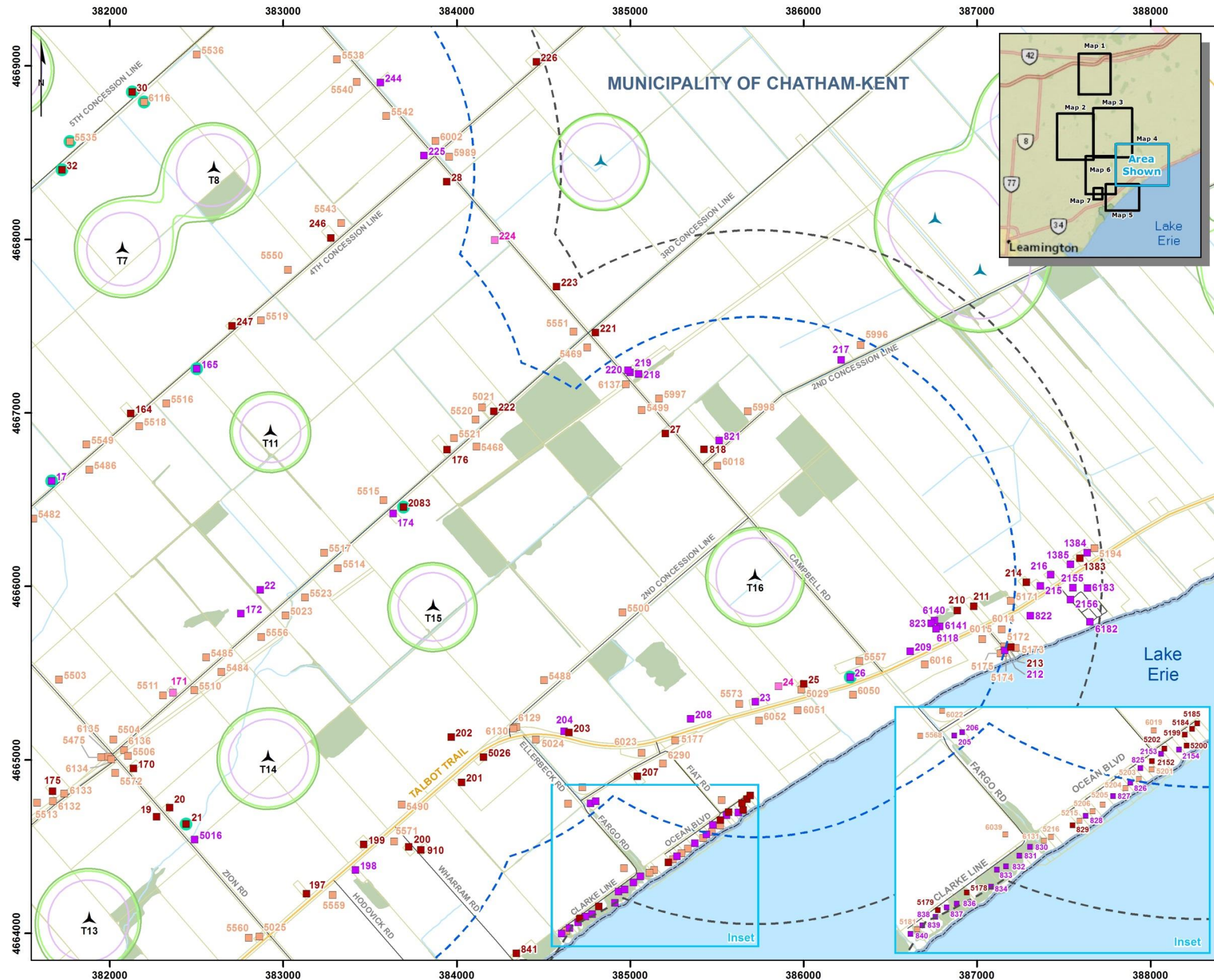

Legend

Project Features	Other Components
▲ Wind turbine (18)	■ 3 Storey Receptor
■ Substation	■ 2 Storey Receptor
■ 1.5 km Buffer from Project Noise Sources	■ 1 Storey Receptor
■ Investigation Area (2 km)	■ Vacant Lot Receptor
	○ POR on Participating Lot
Existing Projects	— Watercourse
<i>Neighbouring wind farm</i>	— Existing HONI
▲ Chatham-Kent Wind Farm	— Transmission Line
▲ Comber Wind Farm	— Highway
▲ Gracey Wind Farm	— Arterial / Collector
▲ Pointe-aux-Roches Wind Farm	— Local Road / Street
▲ Port Alma Wind Farm	— Railroad
▲ Richardson Wind Farm	— Waterbody
▲ South Kent Wind	— Wooded area
	— Built-up area
	— Property Boundary
	— County Boundary
	— Municipal Boundary

Predicted Sound Level Worst Case Wind Speed

- 45 dB(A) at 7.5 m agl*
- 45 dB(A) at 4.5 m agl*
- 45 dB(A) at 1.5 m agl*

*agl: above ground level



ROMNEY
wind energy centre

SIMULATED SOUND ISOCONTOUR LEVELS
[WIND SPEED OF 8 m/s]
Map 4B

10021083-171012-001-LB
October 12, 2017
Layout 88

DNV·GL

Projection: UTM Zone 17, NAD83
Source: Land Information Ontario, ArcGIS Online, Teranet, Callon Dietz

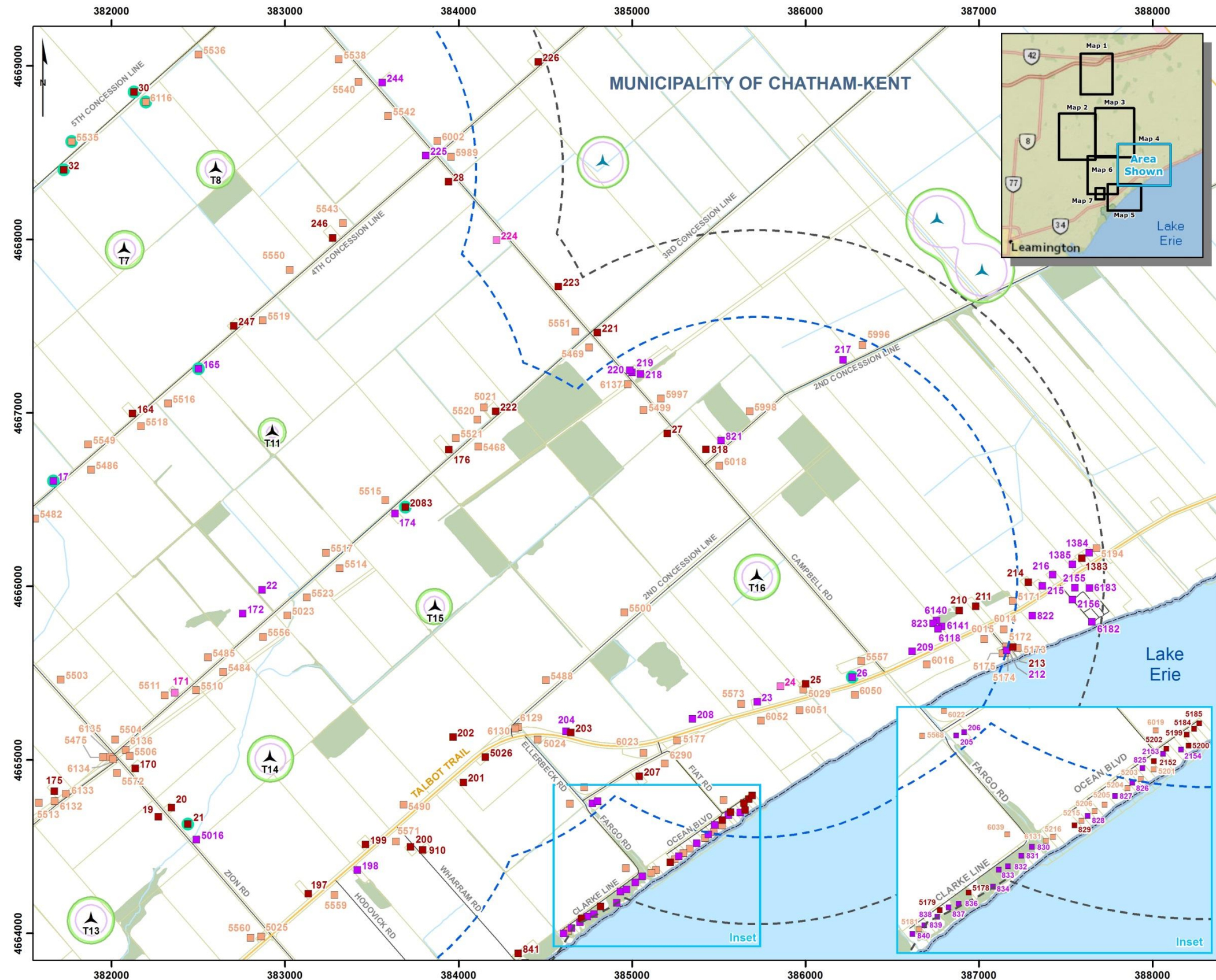

Legend

Project Features	Other Components
▲ Wind turbine (18)	■ 3 Storey Receptor
■ Substation	■ 2 Storey Receptor
■ 1.5 km Buffer from Project Noise Sources	■ 1 Storey Receptor
■ Investigation Area (2 km)	■ Vacant Lot Receptor
	○ POR on Participating Lot
Existing Projects	— Watercourse
<i>Neighbouring wind farm</i>	— Existing HONI
▲ Chatham-Kent Wind Farm	— Transmission Line
▲ Comber Wind Farm	— Highway
▲ Gracey Wind Farm	— Arterial / Collector
▲ Pointe-aux-Roches Wind Farm	— Local Road / Street
▲ Port Alma Wind Farm	— Railroad
▲ Richardson Wind Farm	— Waterbody
▲ South Kent Wind	— Wooded area
	— Built-up area
	— Property Boundary
	— County Boundary
	— Municipal Boundary

Predicted Sound Level Worst Case Wind Speed

- 50 dB(A) at 7.5 m agl*
- 50 dB(A) at 4.5 m agl*
- 50 dB(A) at 1.5 m agl*

*agl: above ground level



ROMNEY
wind energy centre

SIMULATED SOUND ISOCONTOUR LEVELS
[WIND SPEED OF 10 m/s]
Map 4C

10021083-171012-001-LB
October 12, 2017
Layout 88

DNV·GL

Projection: UTM Zone 17, NAD83
Source: Land Information Ontario, ArcGIS Online, Teranet, Callon Dietz

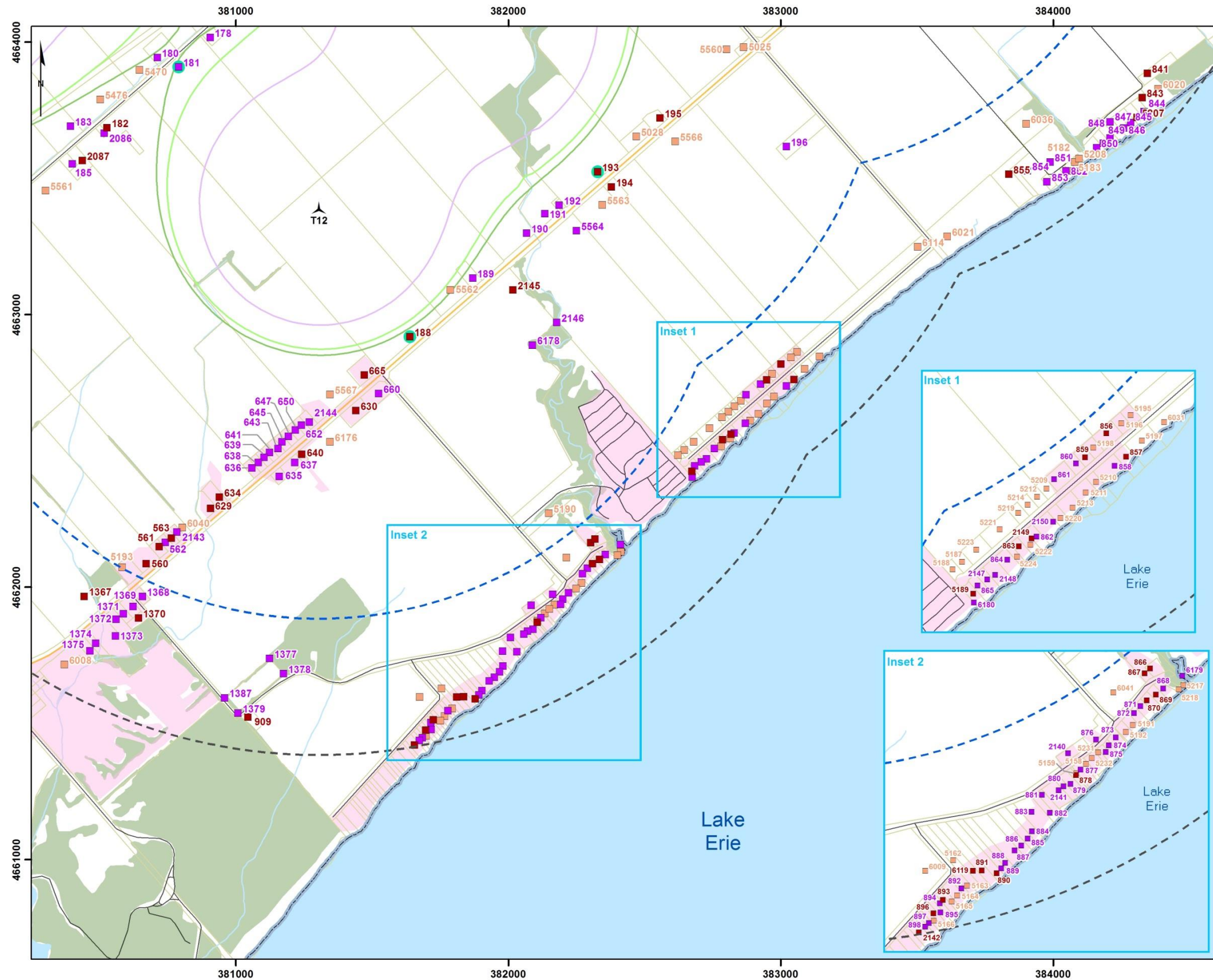

Legend

Project Features	Other Components
Wind turbine (18)	3 Storey Receptor
Substation	2 Storey Receptor
1.5 km Buffer from Project Noise Sources	1 Storey Receptor
Investigation Area (2 km)	Vacant Lot Receptor
	POR on Participating Lot
Existing Projects	Watercourse
Neighbouring wind farm	Existing HONI Transmission Line
Chatham-Kent Wind Farm	Highway
Comber Wind Farm	Arterial / Collector
Gracey Wind Farm	Local Road / Street
Pointe-aux-Roches Wind Farm	Railroad
Port Alma Wind Farm	Waterbody
Richardson Wind Farm	Wooded area
South Kent Wind	Built-up area
	Property Boundary
	County Boundary
	Municipal Boundary

Predicted Sound Level Worst Case Wind Speed

- 40 dB(A) at 7.5 m agl*
- 40 dB(A) at 4.5 m agl*
- 40 dB(A) at 1.5 m agl*

*agl: above ground level

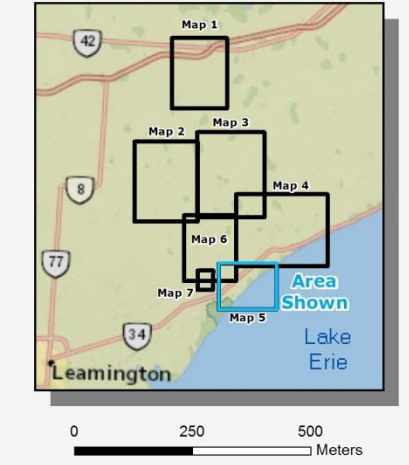

ROMNEY
wind energy centre

SIMULATED SOUND ISOCONTOUR LEVELS
[WIND SPEED OF 6 m/s]
Map 5A

10021083-171012-001-LB
October 12, 2017
Layout 88

DNV·GL
Projection: UTM Zone 17, NAD83
Source: Land Information Ontario, ArcGIS Online, Teranet, Callon Dietz.

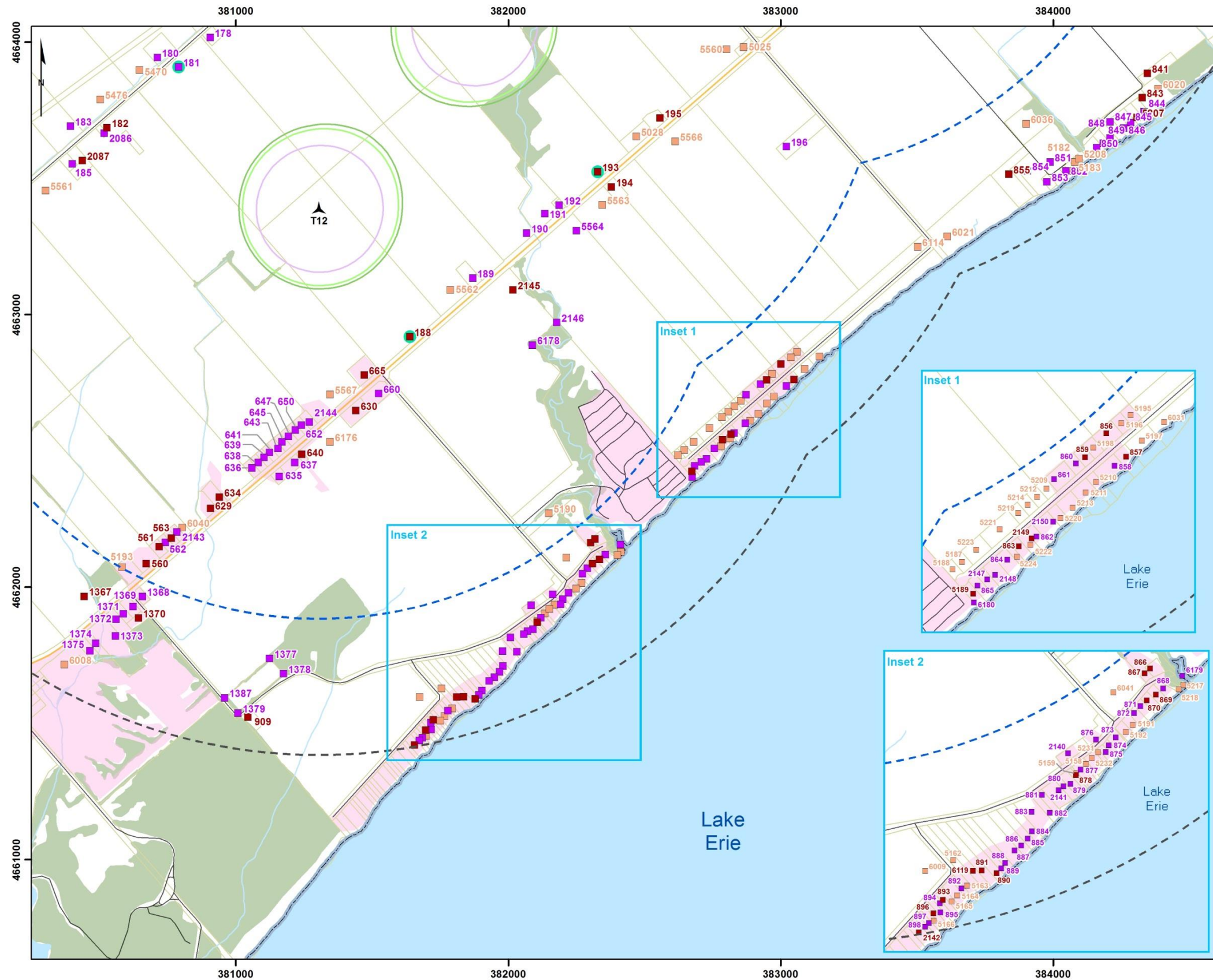

Legend

Project Features	Other Components
▲ Wind turbine (18)	■ 3 Storey Receptor
■ Substation	■ 2 Storey Receptor
■ 1.5 km Buffer from Project Noise Sources	■ 1 Storey Receptor
■ Investigation Area (2 km)	■ Vacant Lot Receptor
	○ POR on Participating Lot
Existing Projects	— Watercourse
▲ Neighbouring wind farm	— Existing HONI Transmission Line
▲ Chatham-Kent Wind Farm	— Highway
▲ Comber Wind Farm	— Arterial / Collector
▲ Gracey Wind Farm	— Local Road / Street
▲ Pointe-aux-Roches Wind Farm	— Railroad
▲ Port Alma Wind Farm	— Waterbody
▲ Richardson Wind Farm	— Wooded area
▲ South Kent Wind	— Built-up area
	— Property Boundary
	— County Boundary
	— Municipal Boundary

Predicted Sound Level Worst Case Wind Speed

- 45 dB(A) at 7.5 m agl*
- 45 dB(A) at 4.5 m agl*
- 45 dB(A) at 1.5 m agl*

*agl: above ground level

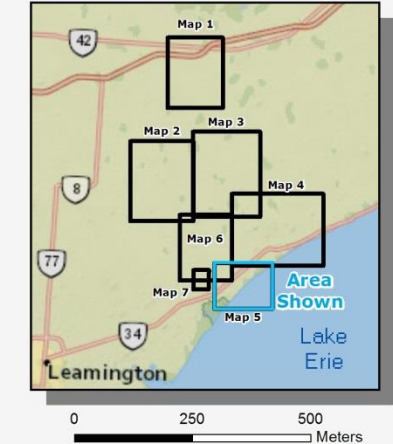

ROMNEY
wind energy centre

SIMULATED SOUND ISOCONTOUR LEVELS
[WIND SPEED OF 8 m/s]
Map 5B

10021083-171012-001-LB
October 12, 2017
Layout 88

DNV·GL
Projection: UTM Zone 17, NAD83
Source: Land Information Ontario, ArcGIS Online, Teranet, Callon Dietz

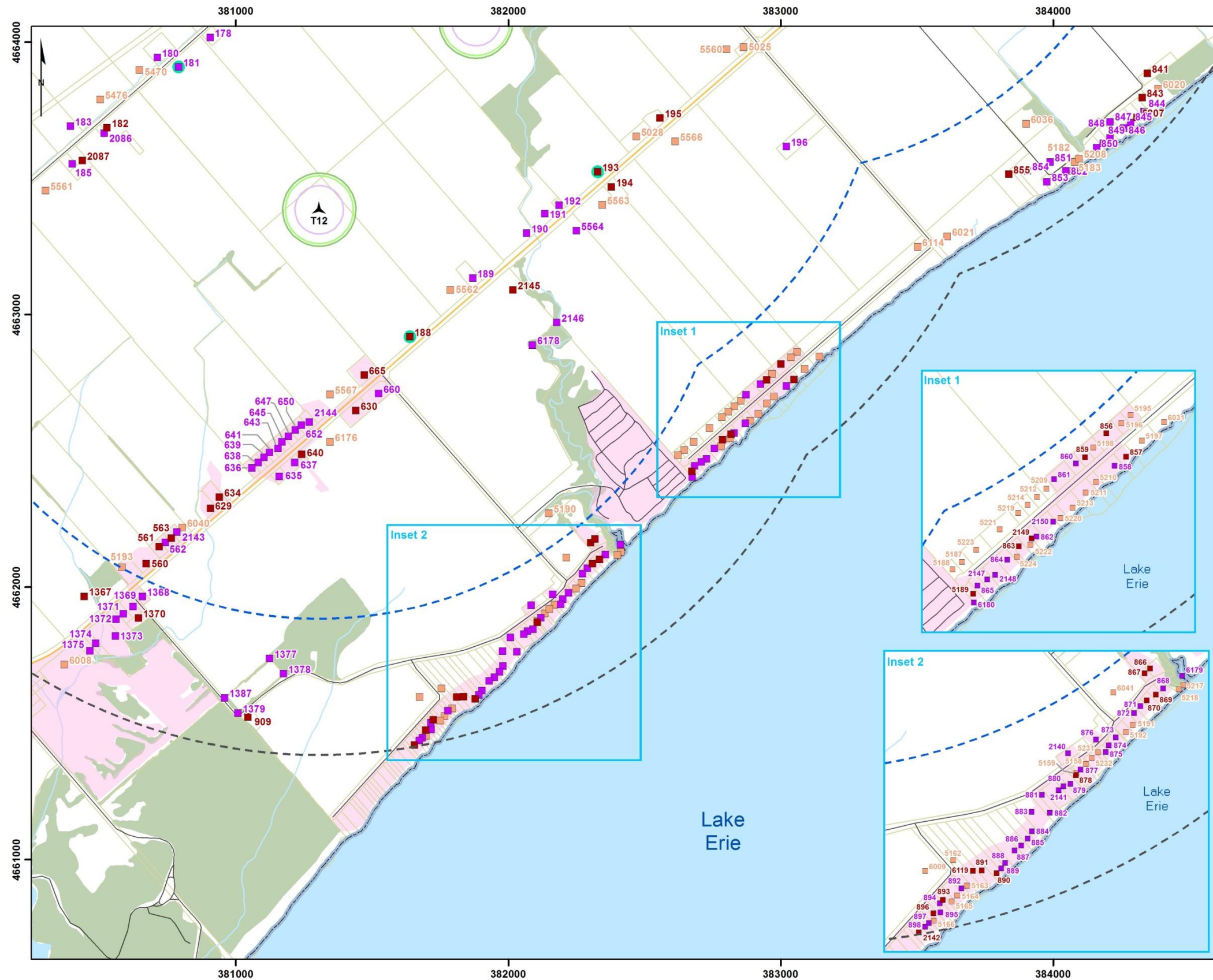

Legend

Project Features	Other Components
▲ Wind turbine (18)	■ 3 Storey Receptor
■ Substation	■ 2 Storey Receptor
■ 1.5 km Buffer from Project Noise Sources	■ 1 Storey Receptor
■ Investigation Area (2 km)	■ Vacant Lot Receptor
	○ POR on Participating Lot
Existing Projects	— Watercourse
▲ Neighbouring wind farm	— Existing HONI Transmission Line
▲ Chatham-Kent Wind Farm	— Highway
▲ Comber Wind Farm	— Arterial / Collector
▲ Gracey Wind Farm	— Local Road / Street
▲ Pointe-aux-Roches Wind Farm	— Railroad
▲ Port Alma Wind Farm	— Waterbody
▲ Richardson Wind Farm	— Wooded area
▲ South Kent Wind	— Built-up area
	— Property Boundary
	— County Boundary
	— Municipal Boundary

Predicted Sound Level Worst Case Wind Speed

- 50 dB(A) at 7.5 m agl*
- 50 dB(A) at 4.5 m agl*
- 50 dB(A) at 1.5 m agl*

*agl: above ground level

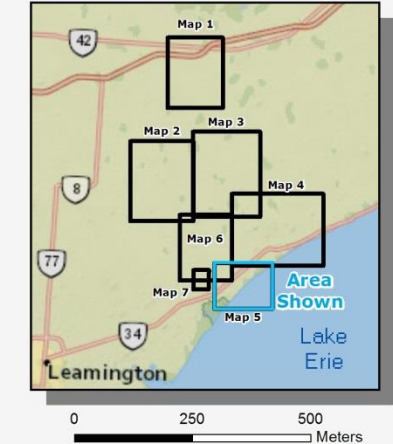

ROMNEY
wind energy centre

SIMULATED SOUND ISOCONTOUR LEVELS
[WIND SPEED OF 10 m/s]
Map 5C

10021083-171012-001-LB
October 12, 2017
Layout 88

DNV·GL

Projection: UTM Zone 17, NAD83
Source: Land Information Ontario, ArcGIS Online, Teranet, Callon Dietz.

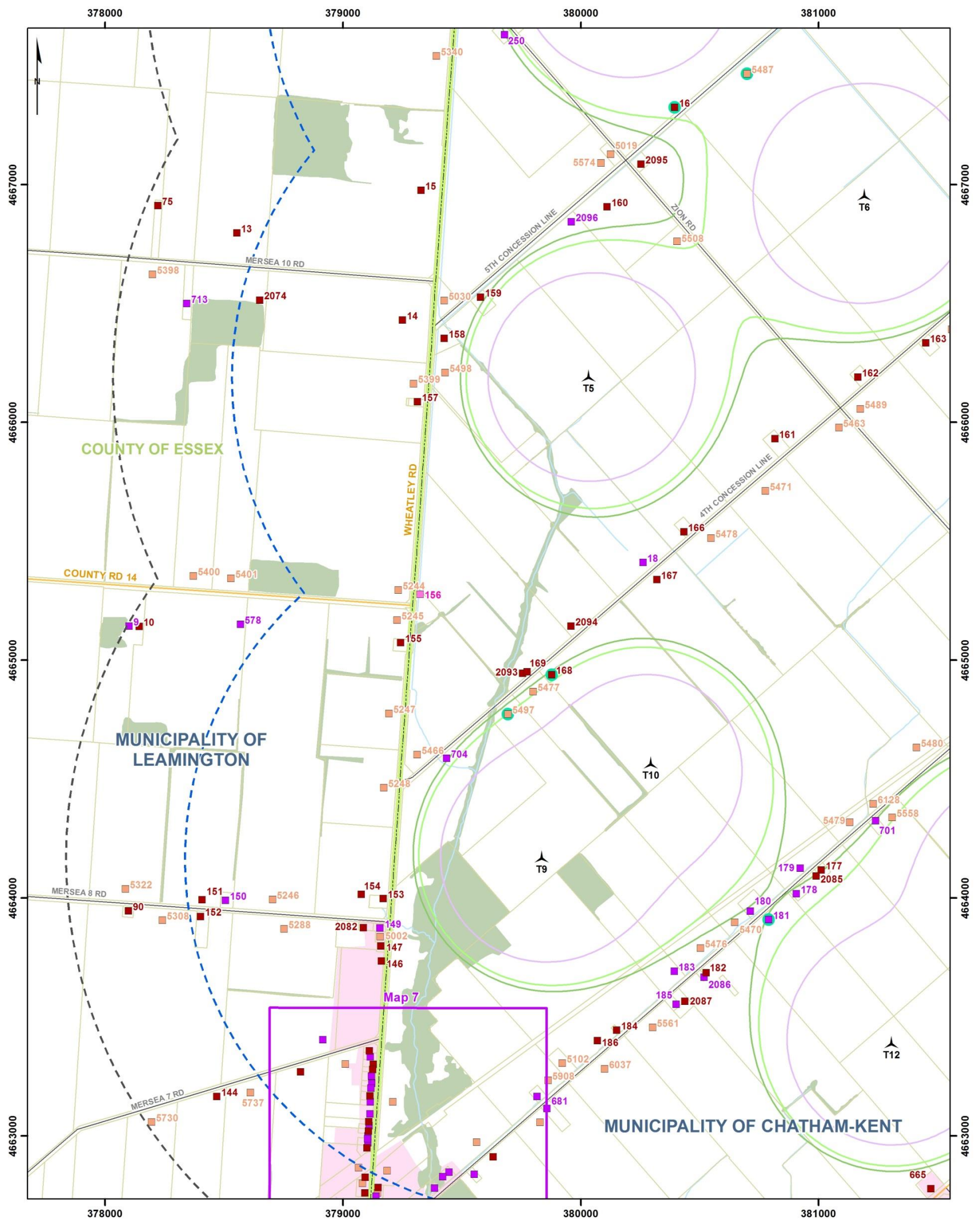

Legend

<p>Project Features</p> <ul style="list-style-type: none"> ▲ Wind turbine (18) ■ Substation — 1.5 km Buffer from Project Noise Sources — Investigation Area (2 km) <p>Existing Projects</p> <ul style="list-style-type: none"> ▲ Neighbouring wind farm ▲ Chatham-Kent Wind Farm ▲ Comber Wind Farm ▲ Gracey Wind Farm ▲ Pointe-aux-Roches Wind Farm ▲ Port Alma Wind Farm ▲ Richardson Wind Farm ▲ South Kent Wind 	<p>Other Components</p> <ul style="list-style-type: none"> ■ 3 Storey Receptor ■ 2 Storey Receptor ■ 1 Storey Receptor ■ Vacant Lot Receptor ● POR on Participating Lot — Watercourse — Existing HONI Transmission Line — Highway — Arterial / Collector — Local Road / Street — Railroad 	<ul style="list-style-type: none"> — Waterbody — Wooded area — Built-up area — Property Boundary — County Boundary — Municipal Boundary <p>Predicted Sound Level Worst Case Wind Speed</p> <ul style="list-style-type: none"> — 40 dB(A) at 7.5 m agl* — 40 dB(A) at 4.5 m agl* — 40 dB(A) at 1.5 m agl* <p>*agl: above ground level</p>
---	---	--

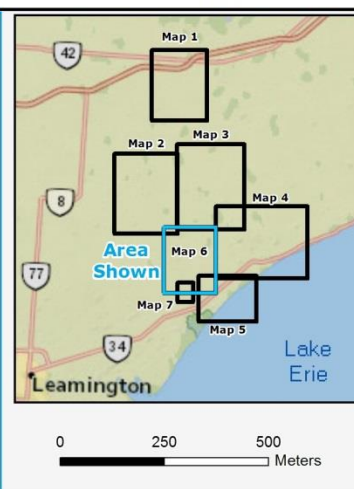

ROMNEY
wind energy centre

SIMULATED SOUND ISOCONTOUR LEVELS
[WIND SPEED OF 6 m/s]
Map 6A

10021083-171012-001-LB
October 12, 2017
Layout 68
Projection: UTM Zone 17, NAD83

DNV·GL

Source: Land Information Ontario, ArcGIS Online, Teranet, Callon Dietz.

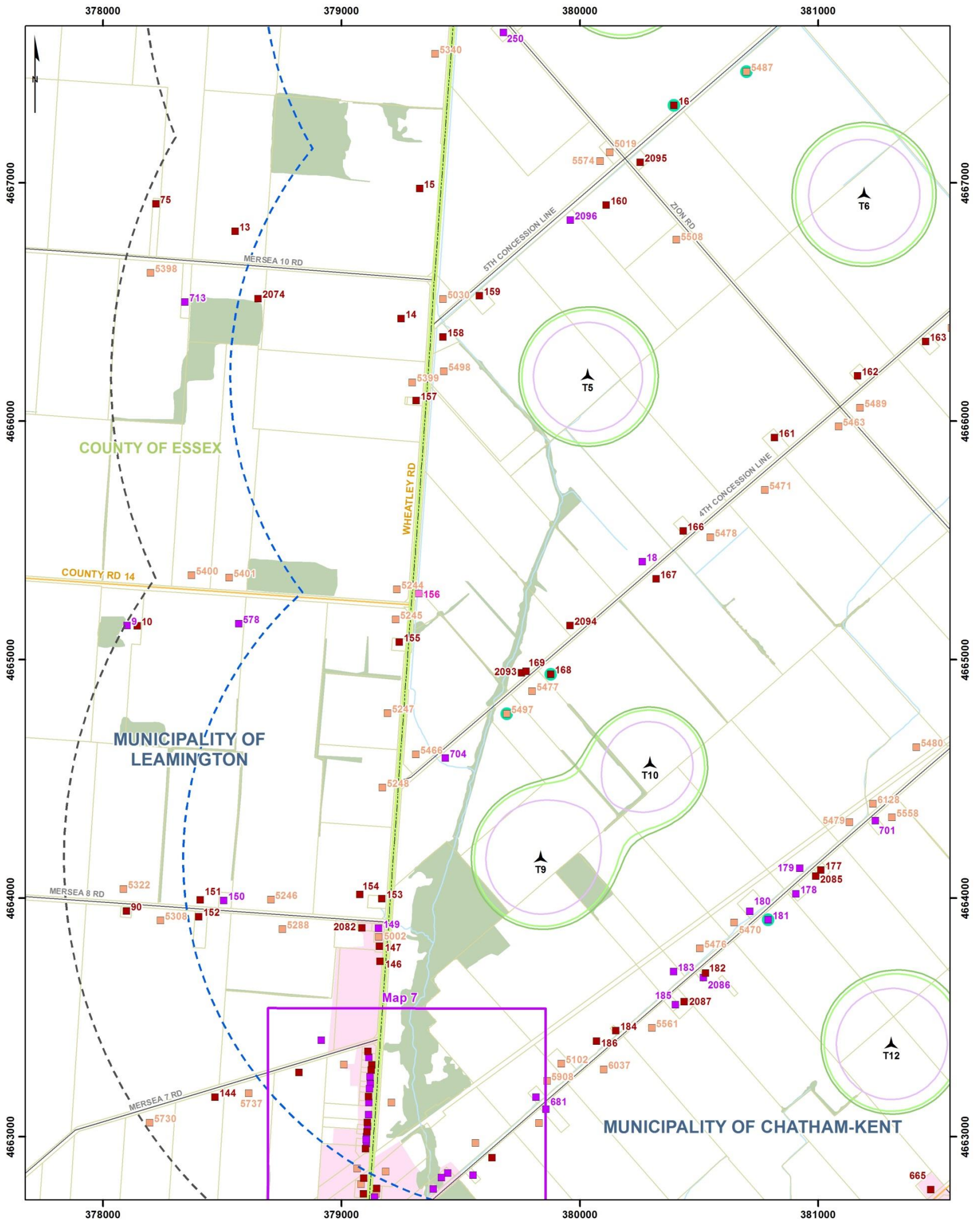

Legend

<p>Project Features</p> <ul style="list-style-type: none"> ▲ Wind turbine (18) ■ Substation □ 1.5 km Buffer from Project Noise Sources □ Investigation Area (2 km) <p>Existing Projects</p> <ul style="list-style-type: none"> ▲ Neighbouring wind farm ▲ Chatham-Kent Wind Farm ▲ Comber Wind Farm ▲ Gracey Wind Farm ▲ Pointe-aux-Roches Wind Farm ▲ Port Alma Wind Farm ▲ Richardson Wind Farm ▲ South Kent Wind 	<p>Other Components</p> <ul style="list-style-type: none"> ■ 3 Storey Receptor ■ 2 Storey Receptor ■ 1 Storey Receptor ■ Vacant Lot Receptor ○ POR on Participating Lot <p>— Watercourse</p> <p>— Existing HONI Transmission Line</p> <p>— Highway</p> <p>— Arterial / Collector</p> <p>— Local Road / Street</p> <p>— Railroad</p>	<ul style="list-style-type: none"> ■ Waterbody ■ Wooded area ■ Built-up area ■ Property Boundary ■ County Boundary ■ Municipal Boundary <p>Predicted Sound Level Worst Case Wind Speed</p> <ul style="list-style-type: none"> — 45 dB(A) at 7.5 m agl* — 45 dB(A) at 4.5 m agl* — 45 dB(A) at 1.5 m agl* <p>*agl: above ground level</p>
---	---	--

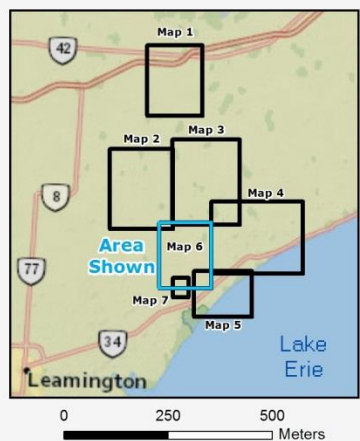

ROMNEY
wind energy centre

SIMULATED SOUND ISOCONTOUR LEVELS
[WIND SPEED OF 8 m/s]
Map 6B

10021083-171012-001-LB
October 12, 2017
Layout 68
Projection: UTM Zone 17, NAD83

DNV·GL

Source: Land Information Ontario, ArcGIS Online, Teranet, Callon Dietz.

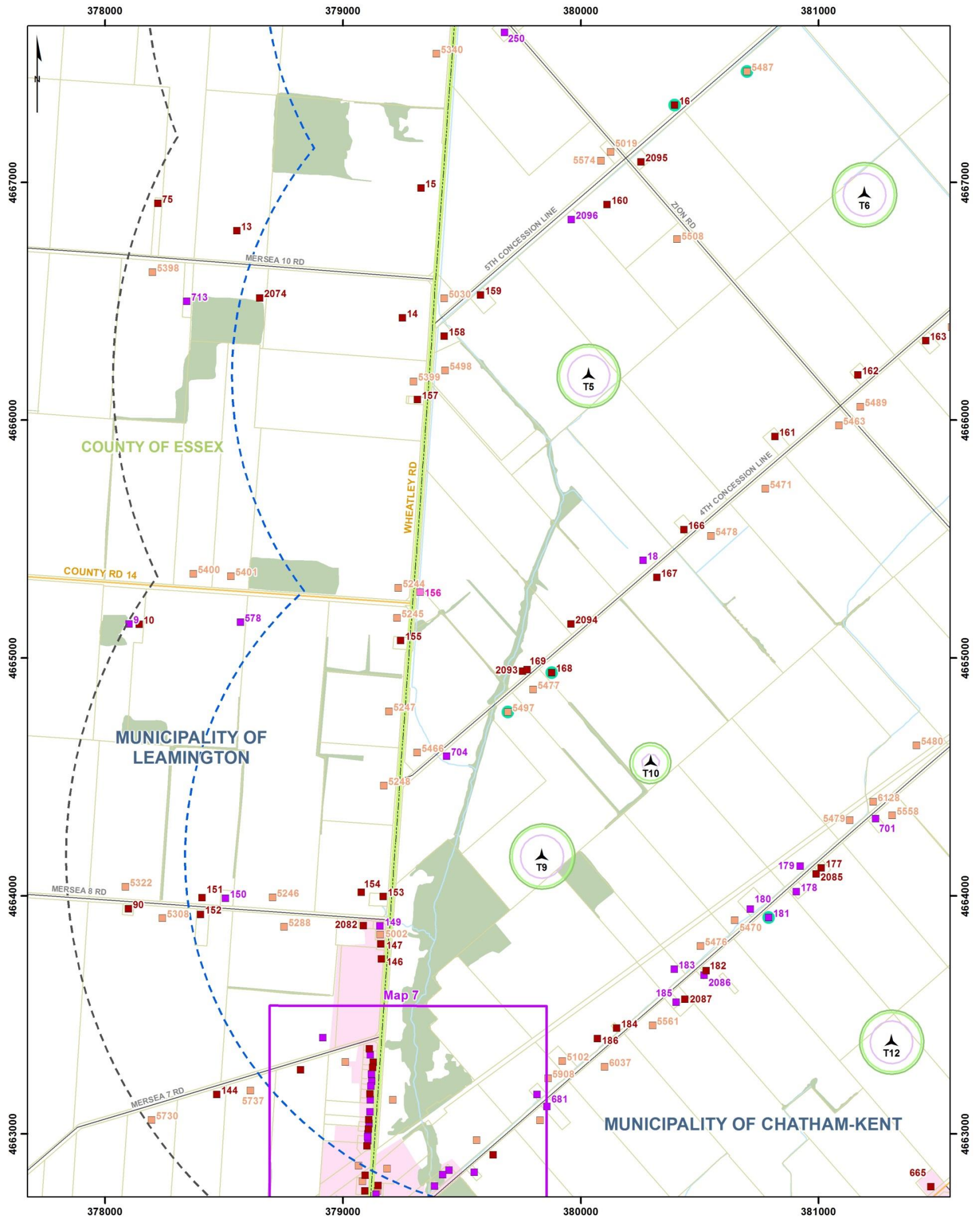

Legend

<p>Project Features</p> <ul style="list-style-type: none"> ▲ Wind turbine (18) ■ Substation □ 1.5 km Buffer from Project Noise Sources □ Investigation Area (2 km) <p>Existing Projects</p> <ul style="list-style-type: none"> ▲ Neighbouring wind farm ▲ Chatham-Kent Wind Farm ▲ Comber Wind Farm ▲ Gracey Wind Farm ▲ Pointe-aux-Roches Wind Farm ▲ Port Alma Wind Farm ▲ Richardson Wind Farm ▲ South Kent Wind 	<p>Other Components</p> <ul style="list-style-type: none"> ■ 3 Storey Receptor ■ 2 Storey Receptor ■ 1 Storey Receptor ■ Vacant Lot Receptor ○ POR on Participating Lot <p>Infrastructure</p> <ul style="list-style-type: none"> — Watercourse — Existing HONI Transmission Line — Highway — Arterial / Collector — Local Road / Street — Railroad 	<ul style="list-style-type: none"> ■ Waterbody ■ Wooded area ■ Built-up area ■ Property Boundary ■ County Boundary ■ Municipal Boundary <p>Predicted Sound Level Worst Case Wind Speed</p> <ul style="list-style-type: none"> — 50 dB(A) at 7.5 m agl* — 50 dB(A) at 4.5 m agl* — 50 dB(A) at 1.5 m agl* <p>*agl: above ground level</p>
---	---	--

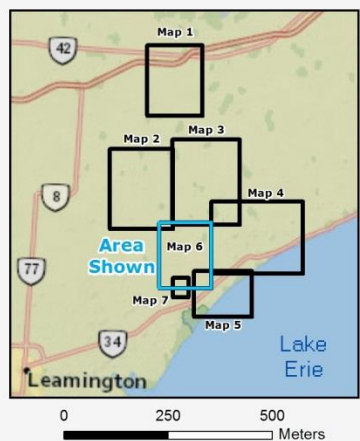

ROMNEY
wind energy centre

SIMULATED SOUND ISOCONTOUR LEVELS
[WIND SPEED OF 10 m/s]
Map 6C

10021083-171012-001-LB
October 12, 2017
Layout 68
Projection: UTM Zone 17, NAD83

DNV·GL

Source: Land Information Ontario, ArcGIS Online, Teranet, Callon Dietz.

APPENDIX D – SAMPLE CALCULATION FOR NOISE MODELING

Resulting A-weighted sound pressure level at Receptor 248 and VLR 257

The calculation of cumulative receptor noise levels from wind turbines uses the methodology of ISO 9613-2, "Acoustics — Attenuation of sound during propagation outdoors: Part 2: General method of calculation". These calculations are conducted with CadnaA (which is an implementation of ISO 9613-1 and ISO 9613-2).

As an example, in this appendix, the results are presented at Receptors 248 and VLR 257. The following inputs and conditions were used:

- Turbine locations;
- Receptor locations.

Turbine characteristics and modelling parameters:

- Hub-heights: as noted in Section 4
- Ambient air temperature: 10°C;
- Ambient barometric pressure: 101.32 kPa;
- Relative humidity: 70%;
- Source ground factor: 0.7;
- Middle ground factor: 0.7;
- Substation gravel area ground factor: 0;
- Receptor ground factor: 0.7.

See Section 5 for source broadband and octave band sound power levels.

The following table presents an example result and intermediate values of the calculations as the A-weighted sound pressure levels at two chosen example receptors, due to each turbine or substation and each octave band. The A-weighted sound pressure levels at the example Receptor 248 and VLR 257 for all bands and all noise sources within 5000 m are 39.9 dBA and 40.0 dBA respectively.

Sample Calculations
Sound pressure levels at Receptor 248

Source ID	Distance* [m]	Octave band sound pressure levels [dBA]									Broadband SPL by source [dBA]
		31.5 Hz	63 Hz	125 Hz	250 Hz	500 Hz	1000 Hz	2000 Hz	4000 Hz	8000 Hz	
T7	812	11.8	21.4	22.0	27.7	28.1	27.7	22.0	-3.9	+	33.6
T3	880	10.2	19.8	20.3	26.0	26.4	25.9	19.7	-7.7	+	31.9
T6	1059	10.6	20.2	20.6	26.2	26.5	25.6	18.4	-13.2	+	31.8
T2	1003	10.1	19.7	20.2	25.7	25.9	25.0	17.4	-15.4	+	31.3
T4	1113	9.9	19.5	20.0	25.7	25.9	25.2	18.3	-12.0	+	31.3
T8	1394	7.1	16.6	17.0	22.4	22.3	20.9	11.6	-27.7	+	27.7
T5	2197	4.2	13.7	13.8	18.7	17.9	15.1	1.0	-56.8	+	23.4
T11	1994	3.0	12.6	12.7	17.7	17.2	14.7	1.8	-51.4	+	22.6
T1	2411	3.4	12.9	12.9	17.7	16.7	13.5	-1.8	-64.7	+	22.3
CH_T49	3221	N/A	4.6	9.3	12.7	14.8	9.2	-13.8	+	+	18.4
CH_T48	3066	N/A	4.8	9.4	12.2	14.2	9.2	-12.8	+	+	18.0
T14	3410	0.3	9.7	9.5	13.6	11.8	6.9	-14.5	+	+	17.9
CH_T47	3439	N/A	4.1	8.7	11.9	13.9	7.9	-16.4	+	+	17.5
A1	3552	0.0	9.4	9.0	13.1	11.1	6.0	-16.2	+	+	17.4
T15	3348	-0.6	8.8	8.5	12.7	10.9	6.2	-14.9	+	+	17.1
CH_T50	3684	N/A	3.7	8.1	11.1	12.9	6.5	-19.3	+	+	16.6
T13	3967	-1.0	8.3	7.9	11.7	9.4	3.5	-21.2	+	+	16.0
CH_T46	3586	N/A	3.8	7.9	10.4	12.0	6.1	-19.1	+	+	15.9
T9	4094	-1.3	8.1	7.6	11.3	8.9	2.8	-22.7	+	+	15.6
T10	3575	-2.1	7.3	7.0	11.0	9.0	3.9	-18.5	+	+	15.3
T12	4613	-2.0	7.3	6.4	9.8	6.9	-0.1	-28.7	+	+	14.1
T16	4854	-2.3	7.0	5.9	9.2	6.1	-1.3	-31.4	+	+	13.5
CH_T58	4767	N/A	1.8	5.5	7.9	8.7	0.4	-31.9	+	+	12.9
Total A-Weighted Sound Pressure Level											39.9

* Includes the heights of noise sources and receptors.

+ indicates values below -88.0 dBA

Sound pressure levels at VLR 257

Source ID	Distance* [m]	Octave band sound pressure levels [dBA]									Broadband SPL by source [dBA]
		31.5 Hz	63 Hz	125 Hz	250 Hz	500 Hz	1000 Hz	2000 Hz	4000 Hz	8000 Hz	
T1	620	15.2	24.9	25.6	31.3	32.0	31.9	27.3	5.8	-63.9	37.6
A1	834	12.7	22.3	22.8	28.5	29.0	28.5	22.6	-3.8	+	34.4
T3	1975	3.1	12.6	12.8	17.9	17.3	14.9	2.1	-50.6	+	22.7
T4	2131	3.4	12.9	13.0	17.9	17.2	14.5	0.8	-55.5	+	22.7
CH_T50	2427	N/A	6.5	11.9	15.8	18.6	14.4	-3.9	-67.1	+	22.0
T2	2586	2.8	12.2	12.2	16.9	15.8	12.3	-4.1	-71.0	+	21.4
CH_T49	2811	N/A	5.5	10.6	14.2	16.7	11.8	-8.8	-80.9	+	20.1
Com14	3297	N/A	4.4	9.1	12.4	14.5	8.8	-14.7	+	+	18.1
CH_T48	3061	N/A	4.8	9.4	12.2	14.2	9.2	-12.7	+	+	18.0
T17	3445	0.2	9.6	9.4	13.5	11.6	6.7	-14.9	+	+	17.8
T7	3351	-0.6	8.8	8.5	12.7	10.9	6.1	-14.9	+	+	17.1
T8	3417	-0.8	8.6	8.3	12.5	10.6	5.7	-15.7	+	+	16.8
T6	3761	-0.5	8.8	8.5	12.4	10.2	4.7	-18.8	+	+	16.7
Com17	3741	N/A	3.6	7.9	11.0	12.6	6.1	-20.0	+	+	16.4
Com13	4037	N/A	3.0	7.2	10.0	11.4	4.4	-23.5	+	+	15.3
Com16	4058	N/A	3.0	7.1	10.0	11.3	4.3	-23.7	+	+	15.2
T5	4289	-1.6	7.8	7.1	10.7	8.1	1.7	-25.0	+	+	15.0
CH_T47	4358	N/A	2.4	6.4	9.1	10.2	2.7	-27.2	+	+	14.2
Com12	4461	N/A	2.3	6.2	8.8	9.8	2.1	-28.4	+	+	13.9
CH_T53	4525	N/A	2.2	6.0	8.6	9.6	1.7	-29.1	+	+	13.7
Com15	4654	N/A	1.9	5.8	8.2	9.1	1.0	-30.6	+	+	13.3
Com11	4889	N/A	1.6	5.3	7.6	8.2	-0.2	-33.3	+	+	12.6
CH_T58	4907	N/A	1.5	5.2	7.5	8.2	-0.3	-33.5	+	+	12.5
T11	4705	-4.1	5.2	4.2	7.6	4.6	-2.5	-31.7	+	+	11.9
Rich1	4989	N/A	3.6	3.9	5.2	5.1	-1.9	-37.0	+	+	10.8
Total A-Weighted Sound Pressure Level											40.0

* Includes the heights of noise sources and receptors.

+ indicates values below -88.0 dBA

Sound pressure levels and attenuations by frequency at VLR 257

ID	X	Y	Z	Ground	LxN	Dist.	hm	Freq	Adiv	Agr	Abar	z	Aatm	Afol	Ahous	LtotN
ROM1	380450	4670257	317	185	79.1	620.22	66.79	32	66.85	-3	0	0	0.02	0	0	15.23
ROM1	380450	4670257	317	185	88.8	620.22	66.79	63	66.85	-3	0	0	0.08	0	0	24.87
ROM1	380450	4670257	317	185	94.3	620.22	66.79	125	66.85	1.55	0	0	0.25	0	0	25.64
ROM1	380450	4670257	317	185	98.9	620.22	66.79	250	66.85	0.07	0	0	0.65	0	0	31.33
ROM1	380450	4670257	317	185	99.1	620.22	66.79	500	66.85	-0.9	0	0	1.2	0	0	31.95
ROM1	380450	4670257	317	185	100.1	620.22	66.79	1000	66.85	-0.9	0	0	2.27	0	0	31.88
ROM1	380450	4670257	317	185	99.2	620.22	66.79	2000	66.85	-0.9	0	0	5.99	0	0	27.26
ROM1	380450	4670257	317	185	92.1	620.22	66.79	4000	66.85	-0.9	0	0	20.32	0	0	5.82
ROM1	380450	4670257	317	185	74.5	620.22	66.79	8000	66.85	-0.9	0	0	72.49	0	0	-63.94
ROMA1	379958	4671291	317	185	79.1	833.51	67.45	32	69.42	-3	0	0	0.03	0	0	12.66
ROMA1	379958	4671291	317	185	88.8	833.51	67.45	63	69.42	-3	0	0	0.1	0	0	22.28
ROMA1	379958	4671291	317	185	94.3	833.51	67.45	125	69.42	1.69	0	0	0.34	0	0	22.85
ROMA1	379958	4671291	317	185	98.9	833.51	67.45	250	69.42	0.07	0	0	0.87	0	0	28.54
ROMA1	379958	4671291	317	185	99.1	833.51	67.45	500	69.42	-0.9	0	0	1.61	0	0	28.97
ROMA1	379958	4671291	317	185	100.1	833.51	67.45	1000	69.42	-0.9	0	0	3.05	0	0	28.53
ROMA1	379958	4671291	317	185	99.2	833.51	67.45	2000	69.42	-0.9	0	0	8.06	0	0	22.63
ROMA1	379958	4671291	317	185	92.1	833.51	67.45	4000	69.42	-0.9	0	0	27.31	0	0	-3.73
ROMA1	379958	4671291	317	185	74.5	833.51	67.45	8000	69.42	-0.9	0	0	97.42	0	0	-91.44
CH_T50	382029	4671600	265	185	-39.4	2426.92	42.23	32	78.7	-3	0	0	0.08	0	0	-115.18
CH_T50	382029	4671600	265	185	82.5	2426.92	42.23	63	78.7	-3	0	0	0.3	0	0	6.5
CH_T50	382029	4671600	265	185	93.4	2426.92	42.23	125	78.7	1.78	0	0	1	0	0	11.92
CH_T50	382029	4671600	265	185	97.1	2426.92	42.23	250	78.7	0.07	0	0	2.53	0	0	15.79
CH_T50	382029	4671600	265	185	101.1	2426.92	42.23	500	78.7	-0.9	0	0	4.68	0	0	18.62
CH_T50	382029	4671600	265	185	101.1	2426.92	42.23	1000	78.7	-0.9	0	0	8.88	0	0	14.42
CH_T50	382029	4671600	265	185	97.4	2426.92	42.23	2000	78.7	-0.9	0	0	23.45	0	0	-3.85
CH_T50	382029	4671600	265	185	90.2	2426.92	42.23	4000	78.7	-0.9	0	0	79.53	0	0	-67.13
CH_T50	382029	4671600	265	185	86.2	2426.92	42.23	8000	78.7	-0.9	0	0	283.66	0	0	-275.26
ROM4	381401	4668982	317	185	78	2131.17	68.13	32	77.57	-3	0	0	0.07	0	0	3.36
ROM4	381401	4668982	317	185	87.7	2131.17	68.13	63	77.57	-3	0	0	0.26	0	0	12.87
ROM4	381401	4668982	317	185	93.2	2131.17	68.13	125	77.57	1.78	0	0	0.88	0	0	12.97
ROM4	381401	4668982	317	185	97.8	2131.17	68.13	250	77.57	0.07	0	0	2.22	0	0	17.93
ROM4	381401	4668982	317	185	98	2131.17	68.13	500	77.57	-0.9	0	0	4.11	0	0	17.22
ROM4	381401	4668982	317	185	99	2131.17	68.13	1000	77.57	-0.9	0	0	7.8	0	0	14.53
ROM4	381401	4668982	317	185	98.1	2131.17	68.13	2000	77.57	-0.9	0	0	20.6	0	0	0.83
ROM4	381401	4668982	317	185	91	2131.17	68.13	4000	77.57	-0.9	0	0	69.84	0	0	-55.51
ROM4	381401	4668982	317	185	73.4	2131.17	68.13	8000	77.57	-0.9	0	0	249.1	0	0	-252.37
ROM3	380880	4668771	316.46	184.46	77.1	1975.08	67.85	32	76.91	-3	0	0	0.06	0	0	3.13
ROM3	380880	4668771	316.46	184.46	86.8	1975.08	67.85	63	76.91	-3	0	0	0.24	0	0	12.65
ROM3	380880	4668771	316.46	184.46	92.3	1975.08	67.85	125	76.91	1.78	0	0	0.81	0	0	12.79

ID	X	Y	Z	Ground	LxN	Dist.	hm	Freq	Adiv	Agr	Abar	z	Aatm	Afol	Ahaus	LtotN
ROM3	380880	4668771	316.46	184.46	96.9	1975.08	67.85	250	76.91	0.07	0	0	2.06	0	0	17.85
ROM3	380880	4668771	316.46	184.46	97.1	1975.08	67.85	500	76.91	-0.9	0	0	3.81	0	0	17.28
ROM3	380880	4668771	316.46	184.46	98.1	1975.08	67.85	1000	76.91	-0.9	0	0	7.22	0	0	14.86
ROM3	380880	4668771	316.46	184.46	97.2	1975.08	67.85	2000	76.91	-0.9	0	0	19.09	0	0	2.1
ROM3	380880	4668771	316.46	184.46	90.1	1975.08	67.85	4000	76.91	-0.9	0	0	64.72	0	0	-50.64
ROM3	380880	4668771	316.46	184.46	72.5	1975.08	67.85	8000	76.91	-0.9	0	0	230.85	0	0	-234.36
ROM2	380172	4667904	313.38	181.38	79.1	2586.8	67.3	32	79.26	-3	0	0	0.08	0	0	2.76
ROM2	380172	4667904	313.38	181.38	88.8	2586.8	67.3	63	79.26	-3	0	0	0.31	0	0	12.23
ROM2	380172	4667904	313.38	181.38	94.3	2586.8	67.3	125	79.26	1.78	0	0	1.06	0	0	12.2
ROM2	380172	4667904	313.38	181.38	98.9	2586.8	67.3	250	79.26	0.07	0	0	2.7	0	0	16.87
ROM2	380172	4667904	313.38	181.38	99.1	2586.8	67.3	500	79.26	-0.9	0	0	4.99	0	0	15.76
ROM2	380172	4667904	313.38	181.38	100.1	2586.8	67.3	1000	79.26	-0.9	0	0	9.46	0	0	12.28
ROM2	380172	4667904	313.38	181.38	99.2	2586.8	67.3	2000	79.26	-0.9	0	0	25	0	0	-4.15
ROM2	380172	4667904	313.38	181.38	92.1	2586.8	67.3	4000	79.26	-0.9	0	0	84.77	0	0	-71.02
ROM2	380172	4667904	313.38	181.38	74.5	2586.8	67.3	8000	79.26	-0.9	0	0	302.35	0	0	-306.21
CH_T49	382658	4670903	265	185	-39.4	2810.43	42.23	32	79.98	-3.29	0	0	0.09	0	0	-116.17
CH_T49	382658	4670903	265	185	82.5	2810.43	42.23	63	79.98	-3.29	0	0	0.34	0	0	5.48
CH_T49	382658	4670903	265	185	93.4	2810.43	42.23	125	79.98	1.69	0	0	1.15	0	0	10.57
CH_T49	382658	4670903	265	185	97.1	2810.43	42.23	250	79.98	-0.01	0	0	2.93	0	0	14.21
CH_T49	382658	4670903	265	185	101.1	2810.43	42.23	500	79.98	-0.99	0	0	5.42	0	0	16.69
CH_T49	382658	4670903	265	185	101.1	2810.43	42.23	1000	79.98	-0.99	0	0	10.28	0	0	11.83
CH_T49	382658	4670903	265	185	97.4	2810.43	42.23	2000	79.98	-0.99	0	0	27.16	0	0	-8.75
CH_T49	382658	4670903	265	185	90.2	2810.43	42.23	4000	79.98	-0.99	0	0	92.1	0	0	-80.89
CH_T49	382658	4670903	265	185	86.2	2810.43	42.23	8000	79.98	-0.99	0	0	328.49	0	0	-321.28
Com14	379552	4673750	262.48	182.48	-39.4	3296.37	41.46	32	81.36	-3.69	0	0	0.11	0	0	-117.17
Com14	379552	4673750	262.48	182.48	82.5	3296.37	41.46	63	81.36	-3.69	0	0	0.4	0	0	4.43
Com14	379552	4673750	262.48	182.48	93.4	3296.37	41.46	125	81.36	1.58	0	0	1.35	0	0	9.11
Com14	379552	4673750	262.48	182.48	97.1	3296.37	41.46	250	81.36	-0.13	0	0	3.44	0	0	12.43
Com14	379552	4673750	262.48	182.48	101.1	3296.37	41.46	500	81.36	-1.11	0	0	6.35	0	0	14.49
Com14	379552	4673750	262.48	182.48	101.1	3296.37	41.46	1000	81.36	-1.11	0	0	12.06	0	0	8.79
Com14	379552	4673750	262.48	182.48	97.4	3296.37	41.46	2000	81.36	-1.11	0	0	31.86	0	0	-14.71
Com14	379552	4673750	262.48	182.48	90.2	3296.37	41.46	4000	81.36	-1.11	0	0	108.02	0	0	-98.08
Com14	379552	4673750	262.48	182.48	86.2	3296.37	41.46	8000	81.36	-1.11	0	0	385.29	0	0	-379.34
CH_T48	382940	4670568	265	185	-39.4	3060.47	42.24	32	80.72	-3.51	0	0	0.1	0	0	-116.7
CH_T48	382940	4670568	265	185	82.4	3060.47	42.24	63	80.72	-3.51	0	0	0.37	0	0	4.83
CH_T48	382940	4670568	265	185	93	3060.47	42.24	125	80.72	1.63	0	0	1.26	0	0	9.4
CH_T48	382940	4670568	265	185	96	3060.47	42.24	250	80.72	-0.08	0	0	3.19	0	0	12.17
CH_T48	382940	4670568	265	185	99.8	3060.47	42.24	500	80.72	-1.05	0	0	5.9	0	0	14.24
CH_T48	382940	4670568	265	185	100.1	3060.47	42.24	1000	80.72	-1.05	0	0	11.19	0	0	9.24
CH_T48	382940	4670568	265	185	96.5	3060.47	42.24	2000	80.72	-1.05	0	0	29.58	0	0	-12.74
CH_T48	382940	4670568	265	185	89.6	3060.47	42.24	4000	80.72	-1.05	0	0	100.29	0	0	-90.35

ID	X	Y	Z	Ground	LxN	Dist.	hm	Freq	Adiv	Agr	Abar	z	Aatm	Afol	Ahaus	LtotN
CH_T48	382940	4670568	265	185	85.7	3060.47	42.24	8000	80.72	-1.05	0	0	357.71	0	0	-351.68
ROM17	376473	4669991	316.37	184.37	79.1	3445.05	68.06	32	81.74	-3	0	0	0.11	0	0	0.25
ROM17	376473	4669991	316.37	184.37	88.8	3445.05	68.06	63	81.74	-3	0	0	0.42	0	0	9.64
ROM17	376473	4669991	316.37	184.37	94.3	3445.05	68.06	125	81.74	1.78	0	0	1.42	0	0	9.36
ROM17	376473	4669991	316.37	184.37	98.9	3445.05	68.06	250	81.74	0.07	0	0	3.59	0	0	13.49
ROM17	376473	4669991	316.37	184.37	99.1	3445.05	68.06	500	81.74	-0.9	0	0	6.64	0	0	11.61
ROM17	376473	4669991	316.37	184.37	100.1	3445.05	68.06	1000	81.74	-0.9	0	0	12.6	0	0	6.66
ROM17	376473	4669991	316.37	184.37	99.2	3445.05	68.06	2000	81.74	-0.9	0	0	33.29	0	0	-14.94
ROM17	376473	4669991	316.37	184.37	92.1	3445.05	68.06	4000	81.74	-0.9	0	0	112.89	0	0	-101.64
ROM17	376473	4669991	316.37	184.37	74.5	3445.05	68.06	8000	81.74	-0.9	0	0	402.66	0	0	-409.01
Com17	377006	4672862	261.55	181.55	-39.4	3740.78	41.9	32	82.46	-3.97	0	0	0.12	0	0	-118.01
Com17	377006	4672862	261.55	181.55	82.5	3740.78	41.9	63	82.46	-3.97	0	0	0.46	0	0	3.55
Com17	377006	4672862	261.55	181.55	93.4	3740.78	41.9	125	82.46	1.49	0	0	1.54	0	0	7.91
Com17	377006	4672862	261.55	181.55	97.1	3740.78	41.9	250	82.46	-0.22	0	0	3.9	0	0	10.95
Com17	377006	4672862	261.55	181.55	101.1	3740.78	41.9	500	82.46	-1.19	0	0	7.21	0	0	12.62
Com17	377006	4672862	261.55	181.55	101.1	3740.78	41.9	1000	82.46	-1.19	0	0	13.68	0	0	6.15
Com17	377006	4672862	261.55	181.55	97.4	3740.78	41.9	2000	82.46	-1.19	0	0	36.15	0	0	-20.02
Com17	377006	4672862	261.55	181.55	90.2	3740.78	41.9	4000	82.46	-1.19	0	0	122.59	0	0	-113.66
Com17	377006	4672862	261.55	181.55	86.2	3740.78	41.9	8000	82.46	-1.19	0	0	437.23	0	0	-432.3
ROM6	381193	4666947	314.76	182.76	79.1	3761.72	68.2	32	82.51	-3	0	0	0.12	0	0	-0.53
ROM6	381193	4666947	314.76	182.76	88.8	3761.72	68.2	63	82.51	-3	0	0	0.46	0	0	8.83
ROM6	381193	4666947	314.76	182.76	94.3	3761.72	68.2	125	82.51	1.78	0	0	1.55	0	0	8.46
ROM6	381193	4666947	314.76	182.76	98.9	3761.72	68.2	250	82.51	0.07	0	0	3.92	0	0	12.39
ROM6	381193	4666947	314.76	182.76	99.1	3761.72	68.2	500	82.51	-0.9	0	0	7.25	0	0	10.24
ROM6	381193	4666947	314.76	182.76	100.1	3761.72	68.2	1000	82.51	-0.9	0	0	13.76	0	0	4.73
ROM6	381193	4666947	314.76	182.76	99.2	3761.72	68.2	2000	82.51	-0.9	0	0	36.35	0	0	-18.76
ROM6	381193	4666947	314.76	182.76	92.1	3761.72	68.2	4000	82.51	-0.9	0	0	123.27	0	0	-112.78
ROM6	381193	4666947	314.76	182.76	74.5	3761.72	68.2	8000	82.51	-0.9	0	0	439.68	0	0	-446.78
ROM7	382074	4667940	317	185	78	3350.81	68.34	32	81.5	-3	0	0	0.11	0	0	-0.61
ROM7	382074	4667940	317	185	87.7	3350.81	68.34	63	81.5	-3	0	0	0.41	0	0	8.79
ROM7	382074	4667940	317	185	93.2	3350.81	68.34	125	81.5	1.78	0	0	1.38	0	0	8.54
ROM7	382074	4667940	317	185	97.8	3350.81	68.34	250	81.5	0.07	0	0	3.5	0	0	12.73
ROM7	382074	4667940	317	185	98	3350.81	68.34	500	81.5	-0.9	0	0	6.46	0	0	10.94
ROM7	382074	4667940	317	185	99	3350.81	68.34	1000	81.5	-0.9	0	0	12.26	0	0	6.14
ROM7	382074	4667940	317	185	98.1	3350.81	68.34	2000	81.5	-0.9	0	0	32.38	0	0	-14.89
ROM7	382074	4667940	317	185	91	3350.81	68.34	4000	81.5	-0.9	0	0	109.81	0	0	-99.41
ROM7	382074	4667940	317	185	73.4	3350.81	68.34	8000	81.5	-0.9	0	0	391.65	0	0	-398.85
ROM8	382601	4668405	317	185	78	3417.31	68.2	32	81.67	-3	0	0	0.11	0	0	-0.78
ROM8	382601	4668405	317	185	87.7	3417.31	68.2	63	81.67	-3	0	0	0.42	0	0	8.61
ROM8	382601	4668405	317	185	93.2	3417.31	68.2	125	81.67	1.78	0	0	1.4	0	0	8.34
ROM8	382601	4668405	317	185	97.8	3417.31	68.2	250	81.67	0.07	0	0	3.57	0	0	12.49

ID	X	Y	Z	Ground	LxN	Dist.	hm	Freq	Adiv	Agr	Abar	z	Aatm	Afol	Ahaus	LtotN
ROM8	382601	4668405	317	185	98	3417.31	68.2	500	81.67	-0.9	0	0	6.59	0	0	10.64
ROM8	382601	4668405	317	185	99	3417.31	68.2	1000	81.67	-0.9	0	0	12.5	0	0	5.73
ROM8	382601	4668405	317	185	98.1	3417.31	68.2	2000	81.67	-0.9	0	0	33.02	0	0	-15.7
ROM8	382601	4668405	317	185	91	3417.31	68.2	4000	81.67	-0.9	0	0	111.99	0	0	-101.76
ROM8	382601	4668405	317	185	73.4	3417.31	68.2	8000	81.67	-0.9	0	0	399.42	0	0	-406.8
Com13	377997	4674040	260.95	180.95	-39.4	4036.84	41.52	32	83.12	-4.12	0	0	0.13	0	0	-118.53
Com13	377997	4674040	260.95	180.95	82.5	4036.84	41.52	63	83.12	-4.12	0	0	0.49	0	0	3
Com13	377997	4674040	260.95	180.95	93.4	4036.84	41.52	125	83.12	1.45	0	0	1.66	0	0	7.17
Com13	377997	4674040	260.95	180.95	97.1	4036.84	41.52	250	83.12	-0.26	0	0	4.21	0	0	10.03
Com13	377997	4674040	260.95	180.95	101.1	4036.84	41.52	500	83.12	-1.23	0	0	7.78	0	0	11.43
Com13	377997	4674040	260.95	180.95	101.1	4036.84	41.52	1000	83.12	-1.23	0	0	14.77	0	0	4.45
Com13	377997	4674040	260.95	180.95	97.4	4036.84	41.52	2000	83.12	-1.23	0	0	39.01	0	0	-23.5
Com13	377997	4674040	260.95	180.95	90.2	4036.84	41.52	4000	83.12	-1.23	0	0	132.29	0	0	-123.97
Com13	377997	4674040	260.95	180.95	86.2	4036.84	41.52	8000	83.12	-1.23	0	0	471.83	0	0	-467.52
Com16	376623	4672887	261.39	181.39	-39.4	4057.5	41.95	32	83.17	-4.13	0	0	0.13	0	0	-118.57
Com16	376623	4672887	261.39	181.39	82.5	4057.5	41.95	63	83.17	-4.13	0	0	0.49	0	0	2.97
Com16	376623	4672887	261.39	181.39	93.4	4057.5	41.95	125	83.17	1.45	0	0	1.67	0	0	7.12
Com16	376623	4672887	261.39	181.39	97.1	4057.5	41.95	250	83.17	-0.26	0	0	4.23	0	0	9.97
Com16	376623	4672887	261.39	181.39	101.1	4057.5	41.95	500	83.17	-1.24	0	0	7.82	0	0	11.35
Com16	376623	4672887	261.39	181.39	101.1	4057.5	41.95	1000	83.17	-1.24	0	0	14.84	0	0	4.33
Com16	376623	4672887	261.39	181.39	97.4	4057.5	41.95	2000	83.17	-1.24	0	0	39.21	0	0	-23.74
Com16	376623	4672887	261.39	181.39	90.2	4057.5	41.95	4000	83.17	-1.24	0	0	132.96	0	0	-124.69
Com16	376623	4672887	261.39	181.39	86.2	4057.5	41.95	8000	83.17	-1.24	0	0	474.25	0	0	-469.98
ROM5	380034	4666186	314.44	182.44	79.1	4289.5	69.26	32	83.65	-3.13	0	0	0.14	0	0	-1.55
ROM5	380034	4666186	314.44	182.44	88.8	4289.5	69.26	63	83.65	-3.13	0	0	0.52	0	0	7.76
ROM5	380034	4666186	314.44	182.44	94.3	4289.5	69.26	125	83.65	1.74	0	0	1.76	0	0	7.15
ROM5	380034	4666186	314.44	182.44	98.9	4289.5	69.26	250	83.65	0.03	0	0	4.48	0	0	10.74
ROM5	380034	4666186	314.44	182.44	99.1	4289.5	69.26	500	83.65	-0.94	0	0	8.27	0	0	8.12
ROM5	380034	4666186	314.44	182.44	100.1	4289.5	69.26	1000	83.65	-0.94	0	0	15.69	0	0	1.7
ROM5	380034	4666186	314.44	182.44	99.2	4289.5	69.26	2000	83.65	-0.94	0	0	41.45	0	0	-24.96
ROM5	380034	4666186	314.44	182.44	92.1	4289.5	69.26	4000	83.65	-0.94	0	0	140.57	0	0	-131.17
ROM5	380034	4666186	314.44	182.44	74.5	4289.5	69.26	8000	83.65	-0.94	0	0	501.36	0	0	-509.57
CH_T47	384190	4669818	265	185	-39.4	4357.86	42.24	32	83.79	-4.25	0	0	0.14	0	0	-119.07
CH_T47	384190	4669818	265	185	82.5	4357.86	42.24	63	83.79	-4.25	0	0	0.53	0	0	2.44
CH_T47	384190	4669818	265	185	93.4	4357.86	42.24	125	83.79	1.41	0	0	1.79	0	0	6.42
CH_T47	384190	4669818	265	185	97.1	4357.86	42.24	250	83.79	-0.3	0	0	4.55	0	0	9.07
CH_T47	384190	4669818	265	185	101.1	4357.86	42.24	500	83.79	-1.28	0	0	8.4	0	0	10.19
CH_T47	384190	4669818	265	185	101.1	4357.86	42.24	1000	83.79	-1.28	0	0	15.94	0	0	2.65
CH_T47	384190	4669818	265	185	97.4	4357.86	42.24	2000	83.79	-1.28	0	0	42.11	0	0	-27.22
CH_T47	384190	4669818	265	185	90.2	4357.86	42.24	4000	83.79	-1.28	0	0	142.81	0	0	-135.12
CH_T47	384190	4669818	265	185	86.2	4357.86	42.24	8000	83.79	-1.28	0	0	509.36	0	0	-505.66

ID	X	Y	Z	Ground	LxN	Dist.	hm	Freq	Adiv	Agr	Abar	z	Aatm	Afol	Ahous	LtotN
Com12	377150	4673997	260.4	180.4	-39.4	4461.11	41.75	32	83.99	-4.3	0	0	0.14	0	0	-119.24
Com12	377150	4673997	260.4	180.4	82.5	4461.11	41.75	63	83.99	-4.3	0	0	0.54	0	0	2.26
Com12	377150	4673997	260.4	180.4	93.4	4461.11	41.75	125	83.99	1.39	0	0	1.83	0	0	6.18
Com12	377150	4673997	260.4	180.4	97.1	4461.11	41.75	250	83.99	-0.32	0	0	4.65	0	0	8.77
Com12	377150	4673997	260.4	180.4	101.1	4461.11	41.75	500	83.99	-1.29	0	0	8.6	0	0	9.8
Com12	377150	4673997	260.4	180.4	101.1	4461.11	41.75	1000	83.99	-1.29	0	0	16.32	0	0	2.08
Com12	377150	4673997	260.4	180.4	97.4	4461.11	41.75	2000	83.99	-1.29	0	0	43.11	0	0	-28.41
Com12	377150	4673997	260.4	180.4	90.2	4461.11	41.75	4000	83.99	-1.29	0	0	146.19	0	0	-138.69
Com12	377150	4673997	260.4	180.4	86.2	4461.11	41.75	8000	83.99	-1.29	0	0	521.42	0	0	-517.92
CH_T53	382926	4673818	263.52	183.52	-39.4	4524.8	41.59	32	84.11	-4.32	0	0	0.14	0	0	-119.34
CH_T53	382926	4673818	263.52	183.52	82.5	4524.8	41.59	63	84.11	-4.32	0	0	0.55	0	0	2.16
CH_T53	382926	4673818	263.52	183.52	93.4	4524.8	41.59	125	84.11	1.39	0	0	1.86	0	0	6.04
CH_T53	382926	4673818	263.52	183.52	97.1	4524.8	41.59	250	84.11	-0.32	0	0	4.72	0	0	8.59
CH_T53	382926	4673818	263.52	183.52	101.1	4524.8	41.59	500	84.11	-1.29	0	0	8.72	0	0	9.56
CH_T53	382926	4673818	263.52	183.52	101.1	4524.8	41.59	1000	84.11	-1.3	0	0	16.55	0	0	1.73
CH_T53	382926	4673818	263.52	183.52	97.4	4524.8	41.59	2000	84.11	-1.3	0	0	43.73	0	0	-29.14
CH_T53	382926	4673818	263.52	183.52	90.2	4524.8	41.59	4000	84.11	-1.3	0	0	148.28	0	0	-140.89
CH_T53	382926	4673818	263.52	183.52	86.2	4524.8	41.59	8000	84.11	-1.3	0	0	528.87	0	0	-525.48
Com15	375808	4672719	261.38	181.38	-39.4	4653.62	42.07	32	84.36	-4.37	0	0	0.15	0	0	-119.54
Com15	375808	4672719	261.38	181.38	82.5	4653.62	42.07	63	84.36	-4.37	0	0	0.57	0	0	1.94
Com15	375808	4672719	261.38	181.38	93.4	4653.62	42.07	125	84.36	1.37	0	0	1.91	0	0	5.76
Com15	375808	4672719	261.38	181.38	97.1	4653.62	42.07	250	84.36	-0.34	0	0	4.86	0	0	8.23
Com15	375808	4672719	261.38	181.38	101.1	4653.62	42.07	500	84.36	-1.31	0	0	8.97	0	0	9.08
Com15	375808	4672719	261.38	181.38	101.1	4653.62	42.07	1000	84.36	-1.31	0	0	17.02	0	0	1.03
Com15	375808	4672719	261.38	181.38	97.4	4653.62	42.07	2000	84.36	-1.31	0	0	44.97	0	0	-30.62
Com15	375808	4672719	261.38	181.38	90.2	4653.62	42.07	4000	84.36	-1.31	0	0	152.5	0	0	-145.35
Com15	375808	4672719	261.38	181.38	86.2	4653.62	42.07	8000	84.36	-1.31	0	0	543.92	0	0	-540.77
Com11	376491	4673992	260.23	180.23	-39.4	4888.9	41.93	32	84.78	-4.44	0	0	0.16	0	0	-119.9
Com11	376491	4673992	260.23	180.23	82.5	4888.9	41.93	63	84.78	-4.44	0	0	0.6	0	0	1.57
Com11	376491	4673992	260.23	180.23	93.4	4888.9	41.93	125	84.78	1.35	0	0	2.01	0	0	5.26
Com11	376491	4673992	260.23	180.23	97.1	4888.9	41.93	250	84.78	-0.36	0	0	5.1	0	0	7.58
Com11	376491	4673992	260.23	180.23	101.1	4888.9	41.93	500	84.78	-1.33	0	0	9.43	0	0	8.22
Com11	376491	4673992	260.23	180.23	101.1	4888.9	41.93	1000	84.78	-1.33	0	0	17.88	0	0	-0.23
Com11	376491	4673992	260.23	180.23	97.4	4888.9	41.93	2000	84.78	-1.33	0	0	47.25	0	0	-33.3
Com11	376491	4673992	260.23	180.23	90.2	4888.9	41.93	4000	84.78	-1.33	0	0	160.21	0	0	-153.46
Com11	376491	4673992	260.23	180.23	86.2	4888.9	41.93	8000	84.78	-1.33	0	0	571.42	0	0	-568.68
CH_T58	384719	4671289	265	185	-39.4	4906.26	42.24	32	84.82	-4.45	0	0	0.16	0	0	-119.92
CH_T58	384719	4671289	265	185	82.5	4906.26	42.24	63	84.82	-4.45	0	0	0.6	0	0	1.54
CH_T58	384719	4671289	265	185	93.4	4906.26	42.24	125	84.82	1.35	0	0	2.02	0	0	5.22
CH_T58	384719	4671289	265	185	97.1	4906.26	42.24	250	84.82	-0.36	0	0	5.12	0	0	7.53
CH_T58	384719	4671289	265	185	101.1	4906.26	42.24	500	84.82	-1.33	0	0	9.46	0	0	8.16

ID	X	Y	Z	Ground	LxN	Dist.	hm	Freq	Adiv	Agr	Abar	z	Aatm	Afol	Ahous	LtotN
CH_T58	384719	4671289	265	185	101.1	4906.26	42.24	1000	84.82	-1.33	0	0	17.95	0	0	-0.33
CH_T58	384719	4671289	265	185	97.4	4906.26	42.24	2000	84.82	-1.33	0	0	47.41	0	0	-33.49
CH_T58	384719	4671289	265	185	90.2	4906.26	42.24	4000	84.82	-1.33	0	0	160.78	0	0	-154.06
CH_T58	384719	4671289	265	185	86.2	4906.26	42.24	8000	84.82	-1.33	0	0	573.45	0	0	-570.73
ROM11	382928	4666887	313.79	181.79	77.1	4705.12	66.76	32	84.45	-3.39	0	0	0.15	0	0	-4.11
ROM11	382928	4666887	313.79	181.79	86.8	4705.12	66.76	63	84.45	-3.39	0	0	0.57	0	0	5.16
ROM11	382928	4666887	313.79	181.79	92.3	4705.12	66.76	125	84.45	1.67	0	0	1.93	0	0	4.25
ROM11	382928	4666887	313.79	181.79	96.9	4705.12	66.76	250	84.45	-0.04	0	0	4.91	0	0	7.58
ROM11	382928	4666887	313.79	181.79	97.1	4705.12	66.76	500	84.45	-1.02	0	0	9.07	0	0	4.59
ROM11	382928	4666887	313.79	181.79	98.1	4705.12	66.76	1000	84.45	-1.02	0	0	17.21	0	0	-2.54
ROM11	382928	4666887	313.79	181.79	97.2	4705.12	66.76	2000	84.45	-1.02	0	0	45.47	0	0	-31.7
ROM11	382928	4666887	313.79	181.79	90.1	4705.12	66.76	4000	84.45	-1.02	0	0	154.19	0	0	-147.52
ROM11	382928	4666887	313.79	181.79	72.5	4705.12	66.76	8000	84.45	-1.02	0	0	549.94	0	0	-560.88
Rich1	379178	4675409	258	180	-39.4	4988.4	40.52	32	84.96	-4.51	0	0	0.16	0	0	-120.01
Rich1	379178	4675409	258	180	84.7	4988.4	40.52	63	84.96	-4.51	0	0	0.61	0	0	3.65
Rich1	379178	4675409	258	180	92.2	4988.4	40.52	125	84.96	1.33	0	0	2.05	0	0	3.86
Rich1	379178	4675409	258	180	95	4988.4	40.52	250	84.96	-0.38	0	0	5.2	0	0	5.22
Rich1	379178	4675409	258	180	98.3	4988.4	40.52	500	84.96	-1.35	0	0	9.62	0	0	5.08
Rich1	379178	4675409	258	180	100	4988.4	40.52	1000	84.96	-1.35	0	0	18.25	0	0	-1.85
Rich1	379178	4675409	258	180	94.8	4988.4	40.52	2000	84.96	-1.35	0	0	48.21	0	0	-37.01
Rich1	379178	4675409	258	180	83.1	4988.4	40.52	4000	84.96	-1.35	0	0	163.47	0	0	-163.98
Rich1	379178	4675409	258	180	78.2	4988.4	40.52	8000	84.96	-1.35	0	0	583.05	0	0	-588.46

Limit. Value D/N:	40	40
Level D/N:	39.9558	39.9558



APPENDIX E – TURBINE NOISE SPECIFICATIONS

This appendix contains the following supporting documentation for the Vestas V136 Turbine models:

- Acoustic emission specifications for each turbine operational mode provided by Vestas [10], [11];
- Guarantee letter from MOECC;
- IEC sound power measurement report summary for operational mode P01, S01 and S02;

Frequency	Hub height wind speed [m/s]																	
	3.0 m/s	3.5 m/s	4.0 m/s	4.5 m/s	5.0 m/s	5.5 m/s	6.0 m/s	6.5 m/s	7.0 m/s	7.5 m/s	8.0 m/s	8.5 m/s	9.0 m/s	9.5 m/s	10.0 m/s	10.5 m/s	11.0 m/s	11.5 m/s
6.3 Hz	19.7	19.4	18.4	18.1	19.3	20.5	21.9	23.3	24.4	25.8	27.3	28.6	29.5	29.8	30.2	30.6	31.1	31.7
8 Hz	21.5	21.4	21.0	21.6	23.4	25.2	27.2	29.2	30.8	32.6	34.5	36.1	37.1	37.4	37.7	38.0	38.2	38.6
10 Hz	27.8	27.6	27.2	27.8	29.6	31.4	33.4	35.4	37.0	38.8	40.7	42.3	43.3	43.6	43.9	44.1	44.4	44.8
12.5 Hz	36.1	36.0	35.6	36.0	37.5	39.2	41.0	43.0	44.6	46.3	48.1	49.7	50.7	51.1	51.3	51.6	51.9	52.3
16 Hz	42.8	42.7	42.3	42.8	44.4	46.0	47.7	49.5	51.0	52.6	54.2	55.7	56.6	56.9	57.1	57.4	57.6	58.0
20 Hz	47.5	47.4	47.1	47.6	49.3	51.1	52.9	54.8	56.4	58.1	59.9	61.4	62.4	62.6	62.9	63.1	63.4	63.7
25 Hz	54.4	54.3	53.9	54.4	56.0	57.7	59.4	61.1	62.6	64.2	65.8	67.2	68.1	68.4	68.6	68.8	69.1	69.4
31.5 Hz	57.4	57.2	56.5	56.7	58.2	59.9	61.6	63.5	65.0	66.7	68.4	70.0	71.1	71.4	71.8	72.1	72.5	73.0
40 Hz	60.7	60.8	61.0	61.9	63.5	65.1	66.9	68.6	70.2	71.9	73.4	74.8	75.6	75.8	75.9	75.9	76.0	76.1
50 Hz	66.0	66.0	66.1	66.7	68.2	69.7	71.3	73.0	74.5	76.1	77.6	79.0	79.8	80.0	80.1	80.2	80.3	80.5
63 Hz	73.9	73.8	73.4	73.5	74.4	75.3	76.3	77.4	78.3	79.4	80.5	81.5	82.1	82.3	82.5	82.7	82.9	83.2
80 Hz	76.7	76.9	77.5	78.1	78.9	79.7	80.7	81.7	82.6	83.6	84.4	85.2	85.6	85.5	85.5	85.5	85.4	85.3
100 Hz	75.1	75.0	74.9	75.3	76.7	78.0	79.5	81.0	82.2	83.6	85.0	86.2	87.0	87.2	87.3	87.5	87.7	87.9
125 Hz	80.2	79.9	79.1	78.8	79.6	80.5	81.5	82.6	83.4	84.4	85.6	86.6	87.3	87.6	87.9	88.3	88.6	89.1
160 Hz	78.2	78.7	79.6	80.9	82.0	83.2	84.4	85.7	87.0	88.1	89.1	90.1	90.4	90.4	90.2	90.0	89.8	89.6
200 Hz	77.9	78.1	78.6	79.6	81.0	82.4	83.9	85.5	87.0	88.4	89.8	91.0	91.7	91.7	91.7	91.7	91.6	91.5
250 Hz	80.8	80.6	80.1	80.4	81.8	83.3	84.8	86.4	87.7	89.2	90.8	92.1	93.0	93.3	93.6	93.8	94.1	94.5
315 Hz	83.5	83.3	82.9	83.0	83.9	85.0	86.1	87.3	88.3	89.4	90.6	91.7	92.4	92.6	92.8	93.0	93.3	93.6
400 Hz	76.6	76.9	77.7	79.1	80.9	82.7	84.5	86.4	88.2	89.8	91.3	92.7	93.4	93.4	93.3	93.2	93.1	92.9
500 Hz	76.8	77.1	77.8	79.2	81.1	83.0	85.0	87.0	88.9	90.7	92.4	93.9	94.7	94.7	94.6	94.5	94.4	94.2
630 Hz	79.1	79.3	79.5	80.3	81.8	83.5	85.2	87.0	88.7	90.3	91.9	93.4	94.2	94.4	94.4	94.5	94.6	94.6
800 Hz	79.4	79.7	80.4	81.4	82.8	84.3	85.9	87.6	89.3	90.8	92.2	93.5	94.2	94.2	94.1	94.0	93.8	93.6
1 kHz	84.6	84.7	84.6	85.0	86.0	87.0	88.2	89.5	90.6	91.8	93.0	94.1	94.8	94.9	95.1	95.2	95.4	95.5
1.25 kHz	81.3	81.6	82.4	83.4	84.8	86.3	87.9	89.6	91.3	92.8	94.2	95.5	96.1	96.1	96.0	95.8	95.7	95.4
1.6 kHz	80.2	80.5	81.1	82.2	83.7	85.2	86.9	88.7	90.3	91.9	93.4	94.7	95.4	95.5	95.4	95.3	95.2	95.1
2 kHz	78.9	79.1	79.6	80.5	82.1	83.7	85.4	87.2	88.8	90.5	92.0	93.3	94.1	94.2	94.2	94.1	94.1	94.1
2.5 kHz	77.0	77.2	77.7	78.8	80.4	82.1	83.8	85.6	87.4	89.0	90.6	92.0	92.7	92.8	92.8	92.8	92.7	92.7
3.15 kHz	74.7	74.9	75.3	76.1	77.6	79.2	80.8	82.6	84.2	85.9	87.4	88.8	89.6	89.7	89.7	89.7	89.8	89.8
4 kHz	72.6	72.6	72.5	72.9	74.1	75.5	76.9	78.5	79.8	81.3	82.7	84.0	84.8	85.0	85.2	85.3	85.5	85.8
5 kHz	64.2	64.2	64.2	64.9	66.5	68.1	69.9	71.7	73.3	75.0	76.6	78.1	79.0	79.2	79.3	79.5	79.6	79.8
6.3 kHz	61.4	61.1	60.4	60.1	60.9	61.9	63.1	64.4	65.5	66.8	68.3	69.6	70.5	70.8	71.3	71.7	72.2	72.8
8 kHz	61.0	60.8	60.3	59.6	59.4	59.4	59.6	59.8	60.0	60.3	60.8	61.2	61.5	61.6	61.9	62.2	62.4	62.8
10 kHz	59.0	59.2	59.7	59.4	58.7	58.2	57.9	57.7	57.6	57.5	57.4	57.3	57.2	57.0	57.0	56.9	56.8	56.8
A-wgt	92.2	92.3	92.5	93.2	94.5	95.9	97.4	99.0	100.5	102.0	103.4	104.7	105.4	105.5	105.5	105.5	105.5	105.5

Table 3: V136-3.6 MW, 3 – 11.5 m/s, expected 1/3 octave band performance, Mode PO1 & PO1 (HWO) - (Blades with serrated trailing edge)

Frequency	Hub height wind speed [m/s]																
	12.0 m/s	12.5 m/s	13.0 m/s	13.5 m/s	14.0 m/s	14.5 m/s	15.0 m/s	15.5 m/s	16.0 m/s	16.5 m/s	17.0 m/s	17.5 m/s	18.0 m/s	18.5 m/s	19.0 m/s	19.5 m/s	20.0 m/s
6.3 Hz	32.1	32.6	32.9	33.2	33.5	33.7	33.9	34.2	34.4	34.6	34.9	35.0	35.2	35.3	35.5	35.6	35.8
8 Hz	38.9	39.1	39.3	39.5	39.6	39.8	39.9	40.0	40.1	40.2	40.4	40.5	40.6	40.6	40.7	40.8	40.9
10 Hz	45.1	45.3	45.5	45.7	45.8	46.0	46.1	46.3	46.3	46.5	46.6	46.7	46.8	46.9	47.0	47.0	47.1
12.5 Hz	52.6	52.9	53.1	53.3	53.4	53.6	53.7	53.9	54.0	54.1	54.3	54.4	54.5	54.6	54.7	54.7	54.8
16 Hz	58.2	58.5	58.6	58.8	59.0	59.1	59.2	59.3	59.4	59.5	59.7	59.7	59.9	59.9	60.0	60.0	60.1
20 Hz	63.9	64.1	64.3	64.5	64.6	64.7	64.8	64.9	65.0	65.1	65.3	65.3	65.4	65.5	65.6	65.6	65.7
25 Hz	69.7	69.9	70.1	70.2	70.4	70.5	70.6	70.8	70.8	71.0	71.1	71.1	71.3	71.3	71.4	71.4	71.5
31.5 Hz	73.4	73.8	74.0	74.3	74.5	74.7	74.9	75.1	75.2	75.4	75.7	75.8	76.0	76.0	76.2	76.3	76.4
40 Hz	76.1	76.2	76.2	76.2	76.3	76.3	76.3	76.3	76.3	76.3	76.3	76.3	76.3	76.3	76.3	76.3	76.3
50 Hz	80.6	80.7	80.8	80.9	80.9	81.0	81.0	81.1	81.1	81.1	81.2	81.2	81.2	81.2	81.3	81.3	81.3
63 Hz	83.5	83.7	83.8	84.0	84.1	84.3	84.3	84.5	84.5	84.7	84.8	84.8	84.9	85.0	85.0	85.1	85.2
80 Hz	85.2	85.2	85.1	85.0	85.0	84.9	84.9	84.8	84.8	84.7	84.6	84.6	84.5	84.5	84.4	84.4	84.3
100 Hz	88.1	88.2	88.3	88.4	88.5	88.6	88.7	88.7	88.8	88.9	88.9	89.0	89.0	89.1	89.1	89.1	89.2
125 Hz	89.5	89.9	90.1	90.4	90.6	90.8	91.0	91.2	91.3	91.5	91.8	91.9	92.0	92.1	92.3	92.4	92.5
160 Hz	89.3	89.1	88.9	88.8	88.6	88.5	88.4	88.2	88.1	87.9	87.7	87.7	87.5	87.4	87.3	87.2	87.1
200 Hz	91.5	91.4	91.3	91.3	91.2	91.2	91.1	91.1	91.0	91.0	90.9	90.8	90.8	90.8	90.7	90.7	90.6
250 Hz	94.8	95.1	95.2	95.4	95.6	95.8	95.9	96.0	96.1	96.3	96.4	96.5	96.6	96.7	96.8	96.9	97.0
315 Hz	93.9	94.1	94.3	94.5	94.6	94.8	94.8	95.0	95.1	95.2	95.3	95.4	95.5	95.6	95.6	95.7	95.8
400 Hz	92.7	92.5	92.4	92.3	92.2	92.0	92.0	91.8	91.7	91.6	91.5	91.4	91.3	91.2	91.1	91.1	91.0
500 Hz	94.0	93.9	93.8	93.6	93.5	93.4	93.3	93.2	93.1	93.0	92.9	92.8	92.7	92.6	92.5	92.5	92.4
630 Hz	94.7	94.7	94.8	94.8	94.8	94.8	94.8	94.8	94.8	94.8	94.8	94.8	94.8	94.8	94.8	94.8	94.8
800 Hz	93.5	93.3	93.2	93.0	92.9	92.8	92.7	92.6	92.5	92.4	92.2	92.2	92.1	92.0	91.9	91.8	91.7
1 kHz	95.7	95.8	95.9	96.0	96.1	96.1	96.2	96.3	96.3	96.3	96.4	96.4	96.5	96.5	96.5	96.6	96.6
1.25 kHz	95.2	95.0	94.9	94.7	94.6	94.4	94.4	94.2	94.1	94.0	93.8	93.7	93.6	93.5	93.4	93.3	93.2
1.6 kHz	94.9	94.8	94.7	94.6	94.5	94.4	94.4	94.2	94.2	94.1	94.0	93.9	93.8	93.8	93.7	93.6	93.6
2 kHz	94.0	93.9	93.9	93.8	93.8	93.8	93.7	93.7	93.6	93.6	93.5	93.5	93.4	93.4	93.3	93.3	93.2
2.5 kHz	92.6	92.5	92.5	92.4	92.4	92.3	92.3	92.2	92.1	92.1	92.0	92.0	91.9	91.9	91.8	91.8	91.7
3.15 kHz	89.8	89.8	89.8	89.8	89.7	89.7	89.7	89.7	89.7	89.6	89.6	89.6	89.6	89.6	89.5	89.5	89.5
4 kHz	85.9	86.1	86.2	86.3	86.4	86.5	86.6	86.7	86.8	86.8	86.9	87.0	87.0	87.1	87.1	87.2	87.2
5 kHz	79.9	80.1	80.1	80.2	80.3	80.3	80.4	80.5	80.5	80.5	80.6	80.6	80.7	80.7	80.7	80.7	80.8
6.3 kHz	73.3	73.8	74.1	74.4	74.7	75.0	75.2	75.5	75.7	75.9	76.2	76.4	76.6	76.7	76.9	77.0	77.2
8 kHz	63.2	63.5	63.6	63.8	64.0	64.2	64.3	64.5	64.6	64.8	64.9	65.0	65.2	65.2	65.4	65.4	65.5
10 kHz	56.7	56.7	56.6	56.6	56.5	56.4	56.4	56.3	56.3	56.2	56.2	56.1	56.1	56.0	56.0	56.0	55.9
A-wgt	105.5	105.5	105.5	105.5	105.5	105.5	105.5	105.5	105.5	105.5	105.5	105.5	105.5	105.5	105.5	105.5	105.5

Table 4: V136-3.6 MW, 12 – 20 m/s, expected 1/3 octave band performance, Mode PO1 & PO1 (HWO) - (Blades with serrated trailing edge)

3.2 Mode SO1 results

Frequency	Hub height wind speed [m/s]																	
	3.0 m/s	3.5 m/s	4.0 m/s	4.5 m/s	5.0 m/s	5.5 m/s	6.0 m/s	6.5 m/s	7.0 m/s	7.5 m/s	8.0 m/s	8.5 m/s	9.0 m/s	9.5 m/s	10.0 m/s	10.5 m/s	11.0 m/s	11.5 m/s
6.3 Hz	21.0	20.3	19.6	20.1	20.5	21.7	22.9	24.1	25.2	26.5	27.8	28.3	28.7	28.8	28.8	29.2	29.6	29.9
8 Hz	22.1	21.9	21.6	22.8	24.0	25.9	27.8	29.6	31.3	33.1	34.8	35.4	36.0	36.1	36.1	36.4	36.7	36.9
10 Hz	28.4	28.2	27.9	29.1	30.3	32.2	34.0	35.8	37.5	39.3	41.0	41.6	42.2	42.3	42.3	42.6	42.9	43.1
12.5 Hz	36.7	36.5	36.2	37.2	38.2	40.0	41.7	43.4	45.1	46.8	48.5	49.1	49.6	49.7	49.8	50.1	50.4	50.6
16 Hz	43.4	43.2	42.9	44.0	45.0	46.7	48.3	49.9	51.4	53.0	54.5	55.1	55.6	55.7	55.7	56.0	56.2	56.4
20 Hz	47.9	47.8	47.6	48.8	49.9	51.7	53.4	55.1	56.8	58.5	60.1	60.7	61.3	61.4	61.4	61.7	61.9	62.1
25 Hz	55.0	54.8	54.5	55.6	56.7	58.3	59.9	61.5	63.0	64.5	66.0	66.6	67.1	67.2	67.2	67.5	67.7	67.9
31.5 Hz	58.4	57.9	57.4	58.3	59.2	60.9	62.5	64.1	65.6	67.3	68.9	69.5	70.0	70.1	70.1	70.5	70.9	71.2
40 Hz	60.6	60.8	61.0	62.3	63.6	65.3	67.0	68.7	70.4	71.9	73.4	74.0	74.6	74.6	74.6	74.7	74.8	74.9
50 Hz	66.0	66.1	66.2	67.3	68.4	70.0	71.6	73.2	74.7	76.2	77.7	78.3	78.8	78.8	78.8	79.0	79.1	79.2
63 Hz	74.4	74.2	74.0	74.5	75.0	75.9	76.8	77.8	78.8	79.8	80.7	81.1	81.5	81.5	81.5	81.7	81.8	81.9
80 Hz	76.2	76.7	77.1	77.9	78.7	79.6	80.5	81.5	82.5	83.4	84.2	84.6	85.0	85.0	84.9	84.8	84.7	84.6
100 Hz	75.3	75.3	75.2	76.2	77.1	78.5	79.8	81.2	82.6	83.9	85.2	85.7	86.1	86.2	86.2	86.4	86.5	86.6
125 Hz	81.2	80.7	80.1	80.4	80.6	81.5	82.3	83.2	84.1	85.1	86.0	86.4	86.7	86.8	86.8	87.1	87.4	87.6
160 Hz	77.3	78.1	78.8	80.1	81.4	82.7	83.9	85.3	86.6	87.7	88.7	89.2	89.6	89.6	89.6	89.4	89.1	89.0
200 Hz	77.4	77.9	78.3	79.6	80.8	82.3	83.8	85.4	86.9	88.3	89.6	90.2	90.7	90.7	90.7	90.7	90.6	90.6
250 Hz	81.5	81.2	80.8	81.7	82.6	84.1	85.5	86.9	88.3	89.7	91.1	91.6	92.1	92.2	92.2	92.5	92.7	92.9
315 Hz	84.0	83.8	83.5	84.1	84.6	85.7	86.7	87.7	88.7	89.8	90.9	91.3	91.7	91.7	91.7	91.9	92.1	92.3
400 Hz	75.9	76.5	77.1	78.8	80.4	82.3	84.2	86.1	87.9	89.5	91.0	91.7	92.3	92.3	92.2	92.1	92.0	92.0
500 Hz	76.1	76.7	77.3	79.0	80.6	82.6	84.6	86.7	88.7	90.4	92.1	92.8	93.4	93.4	93.4	93.4	93.3	93.2
630 Hz	79.0	79.2	79.4	80.7	81.9	83.6	85.3	87.1	88.8	90.4	91.9	92.5	93.1	93.2	93.2	93.3	93.3	93.4
800 Hz	78.7	79.3	79.9	81.1	82.3	83.9	85.5	87.3	89.0	90.5	91.9	92.5	93.1	93.1	93.1	93.0	92.9	92.8
1 kHz	84.8	84.9	84.9	85.6	86.3	87.4	88.5	89.7	90.9	92.1	93.2	93.6	94.0	94.0	94.0	94.2	94.3	94.4
1.25 kHz	80.6	81.2	81.8	83.1	84.3	85.9	87.5	89.3	91.0	92.5	93.9	94.5	95.0	95.0	95.0	94.9	94.7	94.6
1.6 kHz	79.6	80.2	80.7	82.0	83.3	85.0	86.6	88.4	90.2	91.7	93.1	93.7	94.3	94.3	94.3	94.3	94.2	94.1
2 kHz	78.5	78.9	79.3	80.6	81.9	83.6	85.3	87.1	88.8	90.3	91.8	92.4	93.0	93.0	93.0	93.0	93.0	93.0
2.5 kHz	76.5	77.0	77.4	78.8	80.2	82.0	83.7	85.5	87.3	88.9	90.4	91.0	91.6	91.6	91.6	91.6	91.6	91.6
3.15 kHz	74.5	74.8	75.1	76.3	77.5	79.2	80.8	82.6	84.3	85.8	87.3	87.9	88.5	88.5	88.5	88.6	88.6	88.6
4 kHz	72.9	72.9	72.8	73.7	74.6	76.0	77.3	78.8	80.2	81.6	82.9	83.4	83.9	83.9	83.9	84.1	84.3	84.4
5 kHz	64.3	64.4	64.4	65.6	66.8	68.5	70.2	71.9	73.6	75.2	76.7	77.3	77.9	78.0	78.0	78.2	78.3	78.4
6.3 kHz	62.5	61.9	61.3	61.6	61.9	63.0	64.1	65.2	66.3	67.6	68.8	69.3	69.7	69.8	69.8	70.3	70.7	71.0
8 kHz	61.7	61.4	61.0	60.6	60.1	60.2	60.2	60.4	60.5	60.8	61.1	61.3	61.4	61.4	61.4	61.6	61.7	61.8
10 kHz	58.5	59.0	59.4	59.0	58.5	58.2	57.8	57.7	57.5	57.4	57.2	57.2	57.2	57.2	57.1	56.9	56.7	56.5
A-wgt	92.2	92.4	92.5	93.5	94.5	96.0	97.4	99.0	100.5	101.9	103.3	103.9	104.4	104.4	104.4	104.4	104.4	104.4

Table 5: V136-3.45 MW, 3 – 11.5 m/s, expected 1/3 octave band performance, Sound Optimized Mode SO1 & SO1 (HWO) - (Blades with serrated trailing edge)

Frequency	Hub height wind speed [m/s]																
	12.0 m/s	12.5 m/s	13.0 m/s	13.5 m/s	14.0 m/s	14.5 m/s	15.0 m/s	15.5 m/s	16.0 m/s	16.5 m/s	17.0 m/s	17.5 m/s	18.0 m/s	18.5 m/s	19.0 m/s	19.5 m/s	20.0 m/s
6.3 Hz	30.1	30.3	30.4	30.5	30.6	30.7	30.7	30.8	30.8	30.9	31.0	31.1	31.2	31.2	31.1	31.2	31.2
8 Hz	37.1	37.2	37.3	37.4	37.5	37.6	37.6	37.7	37.7	37.7	37.7	37.8	37.8	37.8	37.8	37.9	37.9
10 Hz	43.3	43.4	43.5	43.6	43.7	43.8	43.8	43.9	43.9	43.9	43.9	44.0	44.0	44.0	44.0	44.1	44.1
12.5 Hz	50.8	50.9	51.0	51.1	51.2	51.3	51.3	51.4	51.4	51.5	51.5	51.6	51.6	51.5	51.6	51.6	51.6
16 Hz	56.5	56.6	56.7	56.8	56.9	56.9	56.9	57.0	57.0	57.1	57.1	57.2	57.2	57.2	57.2	57.2	57.2
20 Hz	62.2	62.3	62.4	62.5	62.6	62.6	62.6	62.7	62.7	62.8	62.8	62.9	62.9	62.8	62.9	62.9	62.9
25 Hz	68.0	68.1	68.2	68.3	68.3	68.4	68.4	68.5	68.5	68.5	68.5	68.6	68.6	68.6	68.7	68.7	68.7
31.5 Hz	71.4	71.6	71.7	71.8	71.9	72.0	72.0	72.1	72.1	72.2	72.2	72.3	72.4	72.4	72.3	72.4	72.5
40 Hz	74.9	74.9	74.9	75.0	75.0	75.0	75.0	75.0	75.0	75.0	75.0	75.0	75.0	75.0	75.0	75.0	75.0
50 Hz	79.2	79.3	79.3	79.4	79.4	79.4	79.4	79.5	79.5	79.5	79.5	79.5	79.5	79.5	79.5	79.6	79.6
63 Hz	82.0	82.1	82.1	82.2	82.2	82.2	82.2	82.3	82.3	82.3	82.3	82.4	82.4	82.4	82.4	82.5	82.5
80 Hz	84.5	84.5	84.4	84.3	84.2	84.2	84.2	84.2	84.2	84.2	84.1	84.1	84.1	84.1	84.1	84.1	84.1
100 Hz	86.6	86.7	86.7	86.8	86.8	86.8	86.8	86.9	86.9	86.9	86.9	87.0	87.0	87.0	87.0	87.0	87.0
125 Hz	87.8	87.9	87.9	88.0	88.0	88.1	88.1	88.2	88.3	88.4	88.4	88.5	88.5	88.5	88.6	88.6	88.6
160 Hz	88.8	88.7	88.6	88.6	88.5	88.5	88.4	88.4	88.3	88.3	88.3	88.3	88.2	88.2	88.2	88.2	88.1
200 Hz	90.5	90.5	90.5	90.5	90.4	90.4	90.4	90.4	90.4	90.4	90.4	90.4	90.3	90.4	90.4	90.4	90.3
250 Hz	93.1	93.2	93.2	93.3	93.4	93.5	93.5	93.6	93.6	93.6	93.6	93.7	93.8	93.8	93.7	93.8	93.8
315 Hz	92.4	92.5	92.5	92.5	92.5	92.6	92.6	92.7	92.7	92.8	92.8	92.9	92.9	92.9	92.8	92.9	92.9
400 Hz	91.9	91.9	91.8	91.8	91.8	91.8	91.7	91.7	91.7	91.7	91.6	91.6	91.5	91.6	91.6	91.6	91.5
500 Hz	93.1	93.1	93.1	93.1	93.1	93.1	93.1	93.1	93.0	93.0	93.0	93.0	92.9	92.9	92.9	92.9	92.9
630 Hz	93.4	93.5	93.5	93.5	93.5	93.6	93.6	93.6	93.6	93.6	93.6	93.6	93.6	93.6	93.6	93.6	93.6
800 Hz	92.7	92.7	92.6	92.6	92.5	92.5	92.5	92.5	92.4	92.4	92.4	92.4	92.3	92.4	92.4	92.4	92.3
1 kHz	94.4	94.4	94.4	94.5	94.5	94.5	94.5	94.5	94.5	94.6	94.6	94.6	94.6	94.6	94.6	94.6	94.6
1.25 kHz	94.5	94.5	94.4	94.4	94.3	94.3	94.3	94.3	94.2	94.2	94.1	94.1	94.1	94.1	94.1	94.1	94.0
1.6 kHz	94.0	94.0	94.0	94.0	93.9	93.9	93.9	93.9	93.9	93.9	93.8	93.8	93.8	93.8	93.8	93.8	93.8
2 kHz	93.0	93.0	93.0	93.0	92.9	92.9	92.9	92.9	92.9	92.9	92.9	92.9	92.9	92.9	92.9	92.9	92.9
2.5 kHz	91.6	91.6	91.5	91.5	91.5	91.5	91.5	91.5	91.5	91.5	91.5	91.5	91.5	91.5	91.5	91.5	91.5
3.15 kHz	88.6	88.6	88.6	88.7	88.7	88.7	88.7	88.7	88.7	88.7	88.7	88.7	88.7	88.7	88.7	88.7	88.7
4 kHz	84.5	84.6	84.6	84.7	84.7	84.7	84.7	84.8	84.8	84.8	84.8	84.9	84.9	84.9	84.9	84.9	84.9
5 kHz	78.5	78.6	78.6	78.7	78.7	78.7	78.7	78.8	78.8	78.8	78.8	78.9	78.9	78.9	78.8	78.9	78.9
6.3 kHz	71.2	71.4	71.5	71.6	71.7	71.8	71.9	72.0	72.0	72.1	72.2	72.3	72.4	72.4	72.3	72.4	72.4
8 kHz	61.8	61.8	61.8	61.8	61.8	61.8	61.8	61.9	61.9	62.0	62.0	62.1	62.1	62.1	62.1	62.2	62.2
10 kHz	56.3	56.2	56.1	55.9	55.7	55.7	55.7	55.7	55.6	55.6	55.6	55.6	55.6	55.6	55.6	55.6	55.6
A-wgt	104.4	104.4	104.4	104.4	104.4	104.4	104.4	104.4	104.4	104.4	104.4	104.4	104.4	104.4	104.4	104.4	104.4

Table 6: V136-3.45 MW, 12 – 20 m/s, expected 1/3 octave band performance,
 Sound Optimized Mode SO1 & SO1 (HWO) - (Blades with serrated trailing edge)

Sound Optimized Mode SO1 & SO1 (HWO) - (Blades with serrated trailing edge)

3.3 Mode SO2 results

Frequency	Hub height wind speed [m/s]																	
	3.0 m/s	3.5 m/s	4.0 m/s	4.5 m/s	5.0 m/s	5.5 m/s	6.0 m/s	6.5 m/s	7.0 m/s	7.5 m/s	8.0 m/s	8.5 m/s	9.0 m/s	9.5 m/s	10.0 m/s	10.5 m/s	11.0 m/s	11.5 m/s
6.3 Hz	21.0	20.3	19.6	20.1	20.5	21.7	22.9	24.1	25.2	26.4	27.5	27.6	27.6	27.8	27.9	28.3	28.7	29.0
8 Hz	22.1	21.9	21.6	22.8	24.0	25.9	27.8	29.6	31.3	32.9	34.4	34.6	34.7	34.9	35.0	35.3	35.6	35.9
10 Hz	28.4	28.2	27.9	29.1	30.3	32.2	34.0	35.8	37.5	39.1	40.6	40.8	40.9	41.1	41.2	41.5	41.8	42.1
12.5 Hz	36.7	36.5	36.2	37.2	38.2	40.0	41.7	43.4	45.1	46.6	48.1	48.3	48.4	48.5	48.6	49.0	49.3	49.6
16 Hz	43.4	43.2	42.9	44.0	45.0	46.7	48.3	49.9	51.4	52.8	54.2	54.4	54.5	54.6	54.7	55.0	55.2	55.4
20 Hz	47.9	47.8	47.6	48.8	49.9	51.7	53.4	55.1	56.8	58.3	59.7	59.9	60.1	60.2	60.3	60.6	60.9	61.1
25 Hz	55.0	54.8	54.5	55.6	56.7	58.3	59.9	61.5	63.0	64.4	65.7	65.9	66.0	66.1	66.2	66.5	66.7	66.9
31.5 Hz	58.4	57.9	57.4	58.3	59.2	60.9	62.5	64.1	65.6	67.1	68.5	68.6	68.7	68.9	69.1	69.5	69.9	70.2
40 Hz	60.6	60.8	61.0	62.3	63.6	65.3	67.0	68.7	70.4	71.8	73.1	73.3	73.5	73.6	73.6	73.7	73.8	73.9
50 Hz	66.0	66.1	66.2	67.3	68.4	70.0	71.6	73.2	74.7	76.1	77.4	77.6	77.8	77.9	77.9	78.0	78.1	78.2
63 Hz	74.4	74.2	74.0	74.5	75.0	75.9	76.8	77.8	78.8	79.7	80.5	80.6	80.7	80.8	80.8	81.0	81.1	81.2
80 Hz	76.2	76.7	77.1	77.9	78.7	79.6	80.5	81.5	82.5	83.3	84.1	84.3	84.4	84.4	84.3	84.2	84.0	83.9
100 Hz	75.3	75.3	75.2	76.2	77.1	78.5	79.8	81.2	82.6	83.8	84.9	85.1	85.2	85.3	85.3	85.5	85.6	85.7
125 Hz	81.2	80.7	80.1	80.4	80.6	81.5	82.3	83.2	84.1	85.0	85.8	85.9	85.9	86.0	86.1	86.4	86.6	86.8
160 Hz	77.3	78.1	78.8	80.1	81.4	82.7	83.9	85.3	86.6	87.6	88.5	88.8	89.1	89.0	88.9	88.7	88.4	88.2
200 Hz	77.4	77.9	78.3	79.6	80.8	82.3	83.8	85.4	86.9	88.1	89.3	89.6	89.9	89.9	89.8	89.8	89.7	89.7
250 Hz	81.5	81.2	80.8	81.7	82.6	84.1	85.5	86.9	88.3	89.6	90.8	90.9	91.0	91.1	91.2	91.5	91.8	92.0
315 Hz	84.0	83.8	83.5	84.1	84.6	85.7	86.7	87.7	88.7	89.7	90.7	90.8	90.8	90.9	91.0	91.2	91.3	91.5
400 Hz	75.8	76.5	77.1	78.8	80.4	82.3	84.2	86.1	87.9	89.3	90.7	91.1	91.4	91.4	91.3	91.2	91.1	91.0
500 Hz	76.1	76.7	77.3	79.0	80.6	82.6	84.6	86.7	88.7	90.2	91.7	92.1	92.4	92.4	92.4	92.3	92.2	92.2
630 Hz	79.0	79.2	79.4	80.7	81.9	83.6	85.3	87.1	88.8	90.2	91.6	91.9	92.1	92.1	92.1	92.2	92.3	92.4
800 Hz	78.7	79.3	79.9	81.1	82.3	83.9	85.5	87.3	89.0	90.3	91.6	92.0	92.3	92.3	92.2	92.1	91.9	91.9
1 kHz	84.8	84.9	84.9	85.6	86.3	87.4	88.5	89.7	90.9	91.9	92.9	93.1	93.2	93.3	93.3	93.4	93.5	93.6
1.25 kHz	80.6	81.2	81.8	83.1	84.3	85.9	87.5	89.3	91.0	92.3	93.6	93.9	94.2	94.2	94.1	94.0	93.8	93.7
1.6 kHz	79.6	80.2	80.7	82.0	83.3	85.0	86.6	88.4	90.2	91.5	92.8	93.1	93.4	93.4	93.4	93.3	93.2	93.2
2 kHz	78.5	78.9	79.3	80.6	81.9	83.6	85.3	87.1	88.8	90.2	91.5	91.8	92.0	92.0	92.0	92.0	92.0	92.0
2.5 kHz	76.5	77.0	77.4	78.8	80.2	82.0	83.7	85.5	87.3	88.7	90.1	90.4	90.6	90.6	90.6	90.6	90.6	90.6
3.15 kHz	74.5	74.8	75.1	76.3	77.5	79.2	80.8	82.6	84.3	85.7	87.0	87.3	87.5	87.5	87.5	87.6	87.6	87.7
4 kHz	72.9	72.9	72.8	73.7	74.6	76.0	77.3	78.8	80.2	81.4	82.6	82.8	82.9	83.0	83.0	83.2	83.4	83.5
5 kHz	64.3	64.4	64.4	65.6	66.8	68.5	70.2	71.9	73.6	75.0	76.4	76.6	76.8	76.9	76.9	77.1	77.3	77.4
6.3 kHz	62.5	61.9	61.3	61.6	61.9	63.0	64.1	65.2	66.3	67.5	68.6	68.6	68.6	68.8	68.9	69.4	69.8	70.1
8 kHz	61.7	61.4	61.0	60.6	60.1	60.2	60.2	60.4	60.5	60.8	61.1	61.1	61.0	61.1	61.1	61.2	61.2	61.3
10 kHz	58.5	59.0	59.4	59.0	58.5	58.2	57.8	57.7	57.5	57.4	57.3	57.4	57.4	57.3	57.2	56.9	56.5	56.2
A-wgt	92.2	92.4	92.5	93.5	94.5	96.0	97.4	99.0	100.5	101.8	103.0	103.3	103.5	103.5	103.5	103.5	103.5	103.5

Table 7: V136-3.45 MW, 3 – 11.5 m/s, expected 1/3 octave band performance, Sound Optimized Mode SO2 & SO2 (HWO) - (Blades with serrated trailing edge)

Frequency	Hub height wind speed [m/s]																
	12.0 m/s	12.5 m/s	13.0 m/s	13.5 m/s	14.0 m/s	14.5 m/s	15.0 m/s	15.5 m/s	16.0 m/s	16.5 m/s	17.0 m/s	17.5 m/s	18.0 m/s	18.5 m/s	19.0 m/s	19.5 m/s	20.0 m/s
6.3 Hz	29.2	29.4	29.5	29.6	29.7	29.8	29.8	29.9	30.0	30.1	30.1	30.2	30.3	30.3	30.2	30.3	30.3
8 Hz	36.1	36.2	36.3	36.4	36.4	36.5	36.6	36.7	36.7	36.8	36.8	36.9	36.9	36.9	36.9	37.0	37.0
10 Hz	42.3	42.4	42.5	42.6	42.7	42.8	42.8	42.9	42.9	43.0	43.0	43.1	43.1	43.1	43.1	43.2	43.2
12.5 Hz	49.8	49.9	50.0	50.1	50.2	50.3	50.3	50.4	50.5	50.6	50.6	50.7	50.7	50.7	50.6	50.7	50.7
16 Hz	55.6	55.7	55.8	55.9	55.9	56.0	56.0	56.1	56.1	56.2	56.2	56.3	56.3	56.3	56.3	56.3	56.3
20 Hz	61.2	61.3	61.4	61.5	61.6	61.7	61.7	61.8	61.8	61.9	61.9	62.0	62.0	62.0	61.9	62.0	62.0
25 Hz	67.1	67.2	67.3	67.4	67.4	67.5	67.5	67.6	67.6	67.6	67.6	67.7	67.7	67.7	67.7	67.8	67.8
31.5 Hz	70.4	70.6	70.7	70.8	70.9	71.0	71.0	71.1	71.2	71.3	71.3	71.4	71.5	71.5	71.4	71.5	71.6
40 Hz	73.9	74.0	74.0	74.0	74.0	74.1	74.1	74.1	74.1	74.1	74.1	74.1	74.1	74.1	74.1	74.1	74.1
50 Hz	78.3	78.4	78.4	78.5	78.5	78.5	78.5	78.6	78.6	78.6	78.6	78.6	78.6	78.6	78.6	78.7	78.7
63 Hz	81.3	81.3	81.3	81.4	81.4	81.4	81.4	81.4	81.4	81.4	81.4	81.5	81.5	81.5	81.5	81.6	81.6
80 Hz	83.8	83.7	83.6	83.6	83.5	83.5	83.4	83.4	83.3	83.3	83.3	83.3	83.2	83.2	83.2	83.2	83.2
100 Hz	85.8	85.9	85.9	85.9	85.9	85.9	85.9	86.0	86.0	86.0	86.0	86.1	86.1	86.1	86.1	86.1	86.1
125 Hz	87.0	87.1	87.2	87.2	87.2	87.3	87.3	87.4	87.4	87.5	87.5	87.6	87.6	87.6	87.6	87.7	87.7
160 Hz	88.0	87.9	87.8	87.8	87.7	87.7	87.6	87.6	87.5	87.5	87.4	87.4	87.3	87.3	87.3	87.3	87.2
200 Hz	89.6	89.6	89.6	89.6	89.6	89.6	89.5	89.5	89.5	89.5	89.5	89.5	89.4	89.5	89.5	89.5	89.4
250 Hz	92.2	92.3	92.3	92.4	92.5	92.5	92.5	92.6	92.7	92.7	92.7	92.8	92.9	92.9	92.8	92.9	92.9
315 Hz	91.6	91.7	91.7	91.7	91.7	91.8	91.8	91.8	91.8	91.9	91.9	92.0	92.0	92.0	91.9	92.0	92.0
400 Hz	90.9	90.9	90.9	90.9	90.8	90.8	90.8	90.8	90.7	90.7	90.7	90.7	90.6	90.7	90.7	90.7	90.6
500 Hz	92.2	92.2	92.1	92.1	92.1	92.1	92.1	92.1	92.1	92.1	92.1	92.1	92.0	92.0	92.0	92.0	92.0
630 Hz	92.5	92.5	92.5	92.6	92.6	92.6	92.6	92.7	92.7	92.7	92.7	92.7	92.7	92.7	92.7	92.7	92.7
800 Hz	91.8	91.8	91.7	91.7	91.6	91.6	91.6	91.6	91.5	91.5	91.5	91.5	91.4	91.5	91.5	91.5	91.4
1 kHz	93.6	93.6	93.6	93.6	93.6	93.6	93.6	93.7	93.7	93.7	93.7	93.7	93.7	93.7	93.7	93.7	93.7
1.25 kHz	93.6	93.6	93.5	93.5	93.4	93.4	93.4	93.4	93.3	93.3	93.2	93.2	93.2	93.2	93.2	93.2	93.1
1.6 kHz	93.1	93.1	93.1	93.1	93.0	93.0	93.0	93.0	93.0	93.0	92.9	92.9	92.9	92.9	92.9	92.9	92.9
2 kHz	92.0	92.0	92.0	92.0	92.0	92.0	92.0	92.0	92.0	92.0	92.0	92.0	92.0	92.0	92.0	92.0	92.0
2.5 kHz	90.6	90.6	90.6	90.6	90.6	90.6	90.6	90.6	90.6	90.6	90.6	90.6	90.6	90.6	90.6	90.6	90.6
3.15 kHz	87.7	87.7	87.7	87.7	87.7	87.7	87.7	87.8	87.8	87.8	87.8	87.8	87.8	87.8	87.8	87.8	87.8
4 kHz	83.6	83.7	83.7	83.8	83.8	83.8	83.8	83.9	83.9	83.9	83.9	84.0	84.0	84.0	84.0	84.0	84.0
5 kHz	77.5	77.6	77.6	77.7	77.7	77.8	77.8	77.9	77.9	77.9	77.9	78.0	78.0	78.0	77.9	78.0	78.0
6.3 kHz	70.4	70.5	70.6	70.7	70.8	70.9	70.9	71.0	71.1	71.2	71.3	71.4	71.5	71.5	71.4	71.5	71.5
8 kHz	61.3	61.3	61.2	61.2	61.2	61.2	61.1	61.1	61.1	61.1	61.1	61.2	61.2	61.2	61.2	61.3	61.3
10 kHz	55.9	55.8	55.6	55.5	55.3	55.2	55.1	55.0	54.9	54.9	54.8	54.8	54.7	54.7	54.7	54.7	54.7
A-wgt	103.5	103.5	103.5	103.5	103.5	103.5	103.5	103.5	103.5	103.5	103.5	103.5	103.5	103.5	103.5	103.5	103.5

Table 8: V136-3.45 MW, 12 – 20 m/s, expected 1/3 octave band performance,
 Sound Optimized Mode SO2 & SO2 (HWO) - (Blades with serrated trailing edge)



Vestas American Wind Technology, Inc.
1417 NW Everett Street
Portland, Oregon, 97209

5 October 2017

Frederic Vivo
Manager, Contracts & Technology Evaluation

EDF Energies Nouvelles
1010, rue de la Gauchetiere Ouest, 20e étage bureau 2000
Montreal, QC H3B 2N2

Dear Mr. Vivo,

With respect to the **Romney** project, Vestas warrants the maximum sound power levels and tonal audibility within 3 dB for the turbine configurations listed below, when determined according to the methods described in standard IEC 61400-11, Ed. 3, 2012. In addition, the measurement position of tonal audibility shall be 1.5 meters above terrain, 500 meters downwind, and within +/- 15 degrees of directly behind the test turbine. Measured sound power levels are subject to a test uncertainty equal to 1 dBA.

Turbine Configuration	Maximum Rated Power Level	Maximum Sound Power Level
V136, Mode PO1, with blade serrations	3.60 MW	105.5 dBA and has been tested to a maximum value of 103.9 dBA, which is within 1 dBA uncertainty.
V136, Mode SO1, with blade serrations	3.45 MW	104.4 dBA and has been tested to a maximum value of 104.7 dBA, which is within 1 dBA uncertainty.
V136, Mode SO2, with blade serrations	3.45 MW	103.5 dBA and has been tested to a maximum value of 103.1, which is within 1 dBA uncertainty.

Sincerely,

Travis C. Douville, P.E.
Technical Bid Specialist

Resumé

For the Vestas wind turbine type V136-3.60MW, P01, serial number 212512, the following acoustic data has been determined according to IEC 61400-11 Edition 3.0:

Wind speed Bin (hub height) [m/s]	Power [kW]	Apparent Sound Power level L_{WA} [dB]	Uncertainty U_{LWA} [dB]	Maximum Tonal Audibility ΔL_a [dB]	RPM [min ⁻¹]
7,5	1705	101,0	0,9	No relevant Tone	9,7
8,0	2067	102,2	0,8	No relevant Tone	10,1
8,5	2459	102,8	0,9	-1,1	10,9
9,0	2849	103,1	1,0	No relevant Tone	11,2
9,5	3180	103,5	0,9	No relevant Tone	11,5
10,0	3422	103,6	0,9	No relevant Tone	11,6
10,5	3549	103,6	0,9	No relevant Tone	11,7
11,0	3593	103,8	0,9	No relevant Tone	11,7
11,5	3599	103,5	0,9	No relevant Tone	11,7
12,0	3600	103,8	0,9	No relevant Tone	11,7
12,5	3600	103,9	0,9	No relevant Tone	11,7
13,0	3600	103,4	1,3	No relevant Tone	11,7

Wind speed at 10 m height V_{10} [m/s]	Apparent Sound Power Level $L_{WA,10m}$ [dB re 1 pW]	Uncertainty U_{LWA} [dB]
5	-	-
6	103,0	0,7
7	103,6	0,7
8	103,6	0,7
9	103,2	1,8
10	-	-

Third octave band spectra are found in Enclosure 1. The measurements were carried out on 13 September 2017, at Østerild test site, Denmark. The results were obtained at a horizontal distance of 184 m from the turbine tower centre. The measured tonality is not directly applicable at larger distances.

The results in this report is based on the wind speed at hub height. Therefore, the results are directly applicable at all hub height configurations for this wind turbine.

Resumé

For the Vestas wind turbine type V136-3.45MW, S01, serial number 212512, the following acoustic data has been determined according to IEC 61400-11 Edition 3.0:

Wind speed Bin (hub height) [m/s]	Power [kW]	Apparent Sound Power level L_{WA} [dB]	Uncertainty u_{LWA} [dB]	Maximum Tonal Audibility ΔL_a [dB]	RPM [min^{-1}]
7,0	1382	100,5	1,2	No relevant Tone	9,6
7,5	1704	101,4	1,0	-2,3	10,0
8,0	2061	103,7	0,9	-2,7	10,6
8,5	2440	104,0	0,9	No relevant Tone	11,1
9,0	2813	104,1	0,9	-2,3	11,1
9,5	3069	104,7	0,9	-0,7	11,1
10,0	3221	104,6	0,9	No relevant Tone	11,1
10,5	3285	104,6	0,9	No relevant Tone	11,2
11,0	3319	104,4	1,0	No relevant Tone	11,3
11,5	3345	104,4	1,0	No relevant Tone	11,4
12,0	3365	104,3	1,0	No relevant Tone	11,4
12,5	3381	104,4	1,0	No relevant Tone	11,5
13,0	3403	104,4	1,0	No relevant Tone	11,5
13,5	3429	104,5	1,0	-2,5	11,6
14,0	3442	104,4	1,0	-1,1	11,7
14,5	3448	104,4	1,1	No relevant Tone	11,7
15,0	3450	104,7	1,0	-2,3	11,8
15,5	3450	104,5	1,2	No relevant Tone	11,7

Wind speed at 10 m height V_{10} [m/s]	6	7	8	9	10
Apparent Sound Power Level $L_{WA,10m}$ [dB re 1 pW]	104,1	104,6	104,4	104,4	104,4
Uncertainty u_{LWA} [dB]	0,7	0,7	0,7	0,8	0,9

Third octave band spectra are found in Enclosure 1. The measurements were carried out on 31 May to 2 June 2017, at Østerild test site, Denmark. The results were obtained at a horizontal distance of 184 m from the turbine tower centre. The measured tonality is not directly applicable at larger distances.

The results in this report is based on the wind speed at hub height. Therefore, the results are directly applicable at all hub height configurations for this wind turbine.

Resumé

For the Vestas wind turbine type V136-3.45MW, S02, serial number 212512, the following acoustic data has been determined according to IEC 61400-11 Edition 3.0:

Wind speed Bin (hub height) [m/s]	Power [kW]	Apparent Sound Power level LWA [dB]	Uncertainty U_{LWA} [dB]	Maximum Tonal Audibility ΔL_a [dB]	RPM [min ⁻¹]
7,0	1382	99,8	1,2	-1,6	9,6
7,5	1704	101,3	0,8	-2,9	10,1
8,0	2058	102,1	0,9	No relevant Tone	10,4
8,5	2424	102,2	0,9	No relevant Tone	10,5
9,0	2770	102,2	1,0	-2,5	10,5
9,5	2999	101,7	1,0	No relevant Tone	10,6
10,0	3117	102,1	0,9	No relevant Tone	10,7
10,5	3180	101,9	1,0	No relevant Tone	10,7
11,0	3227	101,9	0,9	No relevant Tone	10,8
11,5	3263	102,2	1,0	No relevant Tone	10,9
12,0	3291	102,7	0,9	No relevant Tone	11,0
12,5	3317	103,1	0,9	No relevant Tone	11,2
13,0	3337	102,7	1,1	No relevant Tone	11,2

Wind speed at 10 m height V_{10} [m/s]	Apparent Sound Power Level $L_{WA,10m}$ [dB re 1 pW]	Uncertainty U_{LWA} [dB]
5	-	-
6	102,2	0,7
7	102,0	0,7
8	102,4	0,7
9	102,5	1,6
10	-	-

Third octave band spectra are found in Enclosure 1. The measurements were carried out on 13 September 2017, at Østerild test site, Denmark. The results were obtained at a horizontal distance of 184 m from the turbine tower centre. The measured tonality is not directly applicable at larger distances.

The results in this report is based on the wind speed at hub height. Therefore, the results are directly applicable at all hub height configurations for this wind turbine.

APPENDIX F – COORDINATES OF TURBINES AND TRANSFORMER

Coordinates of turbines considered in the Romney Wind Energy Centre are listed below in UTM17-NAD83 projection.

Turbine ID	Operational Mode	Easting [m]	Northing [m]	Modelled Broadband PWL [dBA]	Base Elevation [m]
1	P01	380450	4670257	106.0	185
2	P01	380172	4667904	106.0	181
3	S02	380880	4668771	104.0	184
4	S01	381401	4668982	104.9	185
5	P01	380034	4666186	106.0	182
6	P01	381193	4666947	106.0	183
7	S01	382074	4667940	104.9	185
8	S01	382601	4668405	104.9	185
9	P01	379836	4664164	106.0	185
10	S02	380294	4664560	104.0	185
11	S02	382928	4666887	104.0	182
12	P01	381306	4663384	106.0	185
13	P01	381882	4664077	106.0	185
14	P01	382914	4665008	106.0	184
15	S01	383866	4665878	104.9	182
16	P01	385721	4666054	106.0	187
17	P01	376473	4669991	106.0	184
A1	P01	379958	4671291	106.0	185
Transformer	N/A	378771	4678188	103.5	185

Coordinates of the Pointe aux Roches turbines are listed below in UTM17-NAD83 projection.

Turbine ID	Mode	Easting [m]	Northing [m]	Elevation [m]
PAR1	V90 high power – 104.5 dB(A)	378954	4682255	175
PAR2	V90 high power – 104.5 dB(A)	379298	4682125	175
PAR3	V90 high power – 104.5 dB(A)	369268	4682578	180
PAR4	V90 high power – 104.5 dB(A)	378682	4683788	175
PAR5	V90 high power – 104.5 dB(A)	376863	4683716	176
PAR6	V90 high power – 104.5 dB(A)	373738	4682785	180
PAR7	V90 standard – 103.5 dB(A)	373971	4682468	180
PAR8	V90 high power – 104.5 dB(A)	374627	4682602	179
PAR9	V90 high power – 104.5 dB(A)	375221	4682446	179
PAR10	V90 high power – 104.5 dB(A)	372868	4681368	180
PAR11	V90 standard – 103.5 dB(A)	366394	4682177	177
PAR12	V90 high power – 104.5 dB(A)	371858	4682798	180
PAR13	V90 high power – 104.5 dB(A)	373055	4681143	180
PAR14	V90 high power – 104.5 dB(A)	374383	4681241	180
PAR15	V90 standard – 103.5 dB(A)	366463	4681787	179
PAR16	V90 high power – 104.5 dB(A)	367344	4682710	178
PAR17	V90 standard – 103.5 dB(A)	368107	4682657	179
PAR18	V90 high power – 104.5 dB(A)	367180	4681739	180
PAR19	V90 high power – 104.5 dB(A)	377775	4683873	175
PAR20	V90 high power – 104.5 dB(A)	379303	4683641	175
PAR21	V90 high power – 104.5 dB(A)	367711	4682018	180
PAR22	V90 high power – 104.5 dB(A)	370878	4681557	180
PAR23	V90 standard – 103.5 dB(A)	370494	4682598	180
PAR24	V90 high power – 104.5 dB(A)	367097	4682140	179
PAR25	V90 high power – 104.5 dB(A)	371236	4682790	180
PAR26	V90 standard – 103.5 dB(A)	373632	4681422	180
PAR27	V90 high power – 104.5 dB(A)	379920	4683881	175

Coordinates of the Gracey and Richardson turbines are listed below in UTM17-NAD83 projection.

Gracey turbines

Turbine ID	Easting [m]	Northing [m]	Elevation [m]
T-1	376508	4681224	178
T-2	376860	4681053	178
T-3	377221	4681028	178
T-4	377612	4681104	178
T-5	376363	4680538	180

Richardson turbines

Turbine ID	Easting [m]	Northing [m]	Elevation [m]
T-1	379178	4675409	180
T-2	379819	4676535	180
T-3	379645	4676720	180
T-4	379674	4677041	180
T-5	379759	4677704	180

Coordinates for the Port Alma and Chatham turbines are listed below in UTM17-NAD83 projection.

Turbine ID	Easting [m]	Northing [m]	Elevation [m]
PA_T1	390647	4669155	185
PA_T2	390396	4669439	186
PA_T3	390238	4669958	185
PA_T4	389987	4670249	185
PA_T5	391096	4670248	187
PA_T6	390834	4670547	187
PA_T7	393831	4669799	185
PA_T8	393573	4670093	185
PA_T9	393314	4670389	185
PA_T10	393036	4670657	185
PA_T11	392782	4670945	187
PA_T12	392519	4671243	190
PA_T13	392465	4671695	190
PA_T14	395924	4670595	185
PA_T15	395190	4671415	185
PA_T16	394175	4672114	186
PA_T17	393865	4672397	187
PA_T18	394550	4672319	187
PA_T19	394293	4672616	187
PA_T20	398500	4671760	190
PA_T21	398248	4672038	195
PA_T22	398000	4672311	191
PA_T23	397738	4672600	193
PA_T24	401626	4674106	195
PA_T25	402419	4674560	193
PA_T26	402826	4674766	194
PA_T27	402566	4675054	194
PA_T28	402332	4675315	194
PA_T29	403290	4675450	194
PA_T30	403756	4675728	190
PA_T31	404095	4675646	189
PA_T32	404543	4676017	185
PA_T33	404967	4676351	183
PA_T34	404742	4676667	190
PA_T35	404480	4676957	188
PA_T36	405367	4676761	190
PA_T37	405904	4677010	190
PA_T38	405639	4677299	188
PA_T39	406145	4677482	192
PA_T40	405889	4677768	191
PA_T41	406795	4677659	200
PA_T42	406539	4677941	197
PA_T43	407198	4678008	200
PA_T44	406931	4678299	200

Turbine ID	Easting [m]	Northing [m]	Elevation [m]
CH_T45	391879	4678926	185
CH_T46	384831	4668445	183
CH_T47	384190	4669818	185
CH_T48	382940	4670568	185
CH_T49	382658	4670903	185
CH_T50	382029	4671600	185
CH_T51	387019	4667814	182
CH_T52	386759	4668111	182
CH_T53	382926	4673818	184
CH_T54	388889	4667532	190
CH_T55	388653	4667799	185
CH_T56	387925	4668258	186
CH_T57	387354	4668708	185
CH_T58	384719	4671289	185
CH_T59	384248	4673243	185
CH_T60	384728	4675381	183
CH_T61	388779	4670854	185
CH_T62	391814	4669427	185
CH_T63	391559	4669717	185
CH_T64	389320	4672221	186
CH_T65	389054	4672526	185
CH_T66	388387	4673024	185
CH_T67	388177	4673370	185
CH_T68	387962	4673984	185
CH_T69	387707	4674276	185
CH_T70	391169	4672996	188
CH_T71	390962	4673236	187
CH_T72	390800	4673590	187
CH_T73	390539	4673892	186
CH_T74	388183	4675879	185
CH_T75	388043	4676750	183
CH_T76	392929	4674092	188
CH_T77	391847	4677031	185
CH_T78	390648	4675861	185
CH_T79	391186	4675959	185
CH_T80	391580	4676174	185
CH_T81	391251	4676552	185
CH_T82	389949	4676442	185
CH_T83	389896	4676884	185
CH_T84	397044	4671720	192
CH_T85	396901	4671986	192
CH_T86	393107	4675812	187
CH_T87	394615	4675252	188
CH_T88	396659	4674812	190

The coordinates of the Comber turbines are shown below in UTM17-NAD83 projection.

Turbine ID	Easting [m]	Northing [m]	Elevation [m]
Com1	379928	4679201	178
Com2	376175	4678164	180
Com3	377891	4678352	180
Com4	376885	4676930	180
Com5	377576	4676911	180
Com6	375992	4675741	180
Com7	376356	4675687	180
Com8	376685	4675621	180
Com9	377447	4676044	180
Com10	375733	4674336	180
Com11	376491	4673992	180
Com12	377150	4673997	180
Com13	377997	4674040	181
Com14	379552	4673750	182
Com15	375808	4672719	181
Com16	376623	4672887	181
Com17	377006	4672862	182
Com18	373301	4677886	183
Com19	374318	4678308	181
Com20	372799	4675862	182
Com21	374218	4676687	181
Com22	374991	4676958	180
Com23	373214	4674330	181
Com24	373684	4674268	181
Com25	374301	4674394	180
Com26	373298	4673200	182
Com27	373604	4673198	181
Com28	373948	4673157	181
Com29	372893	4671801	183
Com30	374390	4671647	183
Com31	372435	4670314	185
Com32	372894	4670269	185
Com33	369413	4677332	184
Com34	370717	4676284	184
Com35	369452	4674336	185
Com36	370311	4674696	185
Com37	369926	4673208	185
Com38	370872	4673270	184
Com39	368398	4672081	185
Com40	369995	4671678	185
Com41	368343	4670585	186
Com42	369696	4670603	186
Com43	370112	4670632	185
Com44	370658	4670694	185
Com45	359594	4676568	185

Turbine ID	Easting [m]	Northing [m]	Elevation [m]
Com46	359757	4676234	185
Com47	360052	4674436	185
Com48	361505	4677055	185
Com49	361364	4675428	185
Com50	362862	4676753	184
Com51	363438	4676702	183
Com52	362016	4675388	185
Com53	363146	4675314	185
Com54	366091	4674085	185
Com55	366816	4675164	182
Com56	367195	4675596	182
Com57	367475	4675193	182
Com58	367698	4676287	182
Com59	358783	4671599	185
Com60	360203	4672990	185
Com61	360025	4672159	185
Com62	360077	4671299	185
Com63	361568	4672287	185
Com64	361472	4671654	185
Com65	362735	4671934	185
Com66	362704	4671458	185
Com67	364162	4672915	185
Com68	365556	4672664	185
Com69	365433	4671607	185
Com70	367049	4672886	185
Com71	366912	4671667	185
Com72	366945	4671205	186

The coordinates of the South Kent turbines are shown below in UTM17-NAD83 projection.

Turbine ID	Easting [m]	Northing [m]	Elevation [m]
SK_P001	427178	4692161	201
SK_P002	426061	4690917	198
SK_P005	422385	4691692	215
SK_P003	425156	4690558	198
SK_P004	424640	4690695	200
SK_P006	424092	4690372	201
SK_P007	423971	4689963	199
SK_P008	424169	4689742	197
SK_P009	423544	4689891	200
SK_P010	421228	4698447	194
SK_P012	422688	4696863	198
SK_P013	420640	4696661	195
SK_P014	421756	4695475	199
SK_P016	419033	4696469	191
SK_P017	417719	4696704	190
SK_P018	418617	4695798	193
SK_P019	420115	4695160	196
SK_P020	419688	4694836	196
SK_P021	419870	4694471	197
SK_P022	420309	4693988	199
SK_P023	417697	4694920	194
SK_P024	417289	4694493	194
SK_P026	418575	4692559	199
SK_P028	418682	4691948	200
SK_P029	418305	4691944	200
SK_P030	418038	4691264	200
SK_P031	416174	4693635	195
SK_P032	413831	4693771	185
SK_P033	413757	4693358	187
SK_P034	414888	4692466	193
SK_P035	415855	4690672	196
SK_P036	416216	4690490	197
SK_P037	412113	4692132	185
SK_P038	412361	4691940	187
SK_P039	413480	4691456	192
SK_P040	413632	4691151	194
SK_P041	414504	4690492	195
SK_P042	416257	4689982	198
SK_P044	410690	4691528	185
SK_P045	411013	4691391	185
SK_P046	411354	4691277	185
SK_P052	409952	4690387	185
SK_P053	411967	4689090	192
SK_P054	407634	4690439	181
SK_P055	408036	4690106	182

Turbine ID	Easting [m]	Northing [m]	Elevation [m]
SK_P056	408830	4689187	185
SK_P057	409174	4688870	186
SK_P058	409543	4688714	189
SK_P060	406654	4687622	184
SK_P061	401994	4686710	180
SK_P062	399034	4686942	180
SK_P063	398390	4686456	180
SK_P064	397209	4685275	180
SK_P065	400337	4685539	180
SK_P066	395742	4684150	181
SK_P067	394778	4683606	180
SK_P068	394465	4682973	181
SK_P069	393513	4681304	183
SK_P070	393479	4678630	185
SK_P071	389181	4681142	181
SK_P072	388878	4680871	181
SK_P073	389751	4679985	184
SK_P074	388099	4679530	183
SK_P075	386454	4678536	180
SK_P077	385937	4678593	180
SK_P078	385533	4678652	180
SK_P079	383680	4679895	180
SK_P080	382353	4676988	180
SK_P081	383059	4676071	180
SK_P082	382293	4675209	181
SK_P087	393965	4678292	186
SK_P091	420003	4697353	194
SK_P092	422224	4694845	201
SK_P093	425231	4693641	215
SK_P094	402314	4685254	181
SK_P095	391731	4681450	182
SK_P097	404728	4689265	180
SK_P098	401182	4686250	180
SK_P099	394491	4684887	180
SK_P100	407888	4688332	185
SK_P101	422771	4696463	199
SK_P102	423528	4693524	215
SK_P104	429578	4690825	185
SK_P106	427440	4689213	185
SK_P107	427437	4688879	185
SK_P108	415828	4691264	196
SK_P109	416644	4689364	200
SK_P111	404802	4687495	181
SK_P113	386031	4679914	180
SK_P115	384576	4679720	180
SK_P116	383689	4678419	180
SK_P118	428450	4690369	186

Turbine ID	Easting [m]	Northing [m]	Elevation [m]
SK_P120	415836	4689943	198
SK_P121	398610	4686722	180
SK_P122	384553	4677259	180
SK_P124	389653	4678965	185
SK_P125	389927	4682234	180
SK_P126	390625	4682577	180
SK_P132	386947	4678576	181
SK_P133	420381	4693499	200
SK_P135	417075	4692589	195
SK_P138	427231	4691758	200
SK_P139	425811	4687632	181
SK_P140	421740	4685807	185
SK_P145	421551	4700277	190
SK_P148	397161	4685625	180
SK_P149	403547	4688383	180
SK_P150	385256	4679726	180
SK_P152	423266	4694041	215
SK_P154	382454	4677723	180
SK_P155	417767	4693110	197
SK_P156	416627	4694265	192
SK_P161	391652	4683469	180
SK_P162	408837	4691294	185
SK_P163	405393	4689767	180
SK_P164	406586	4688921	181
SK_P166	425648	4693212	215
SK_P167	423821	4690666	204
SK_P168	422182	4697457	196
SK_P171	427325	4688582	182
SK_P173	418164	4697127	190
SK_P174	396913	4676679	190
SK_P175	396352	4676622	189
SK_P176	395202	4676916	188



APPENDIX G – ROMNEY EXAMPLE TRANSFORMER DIAGRAM

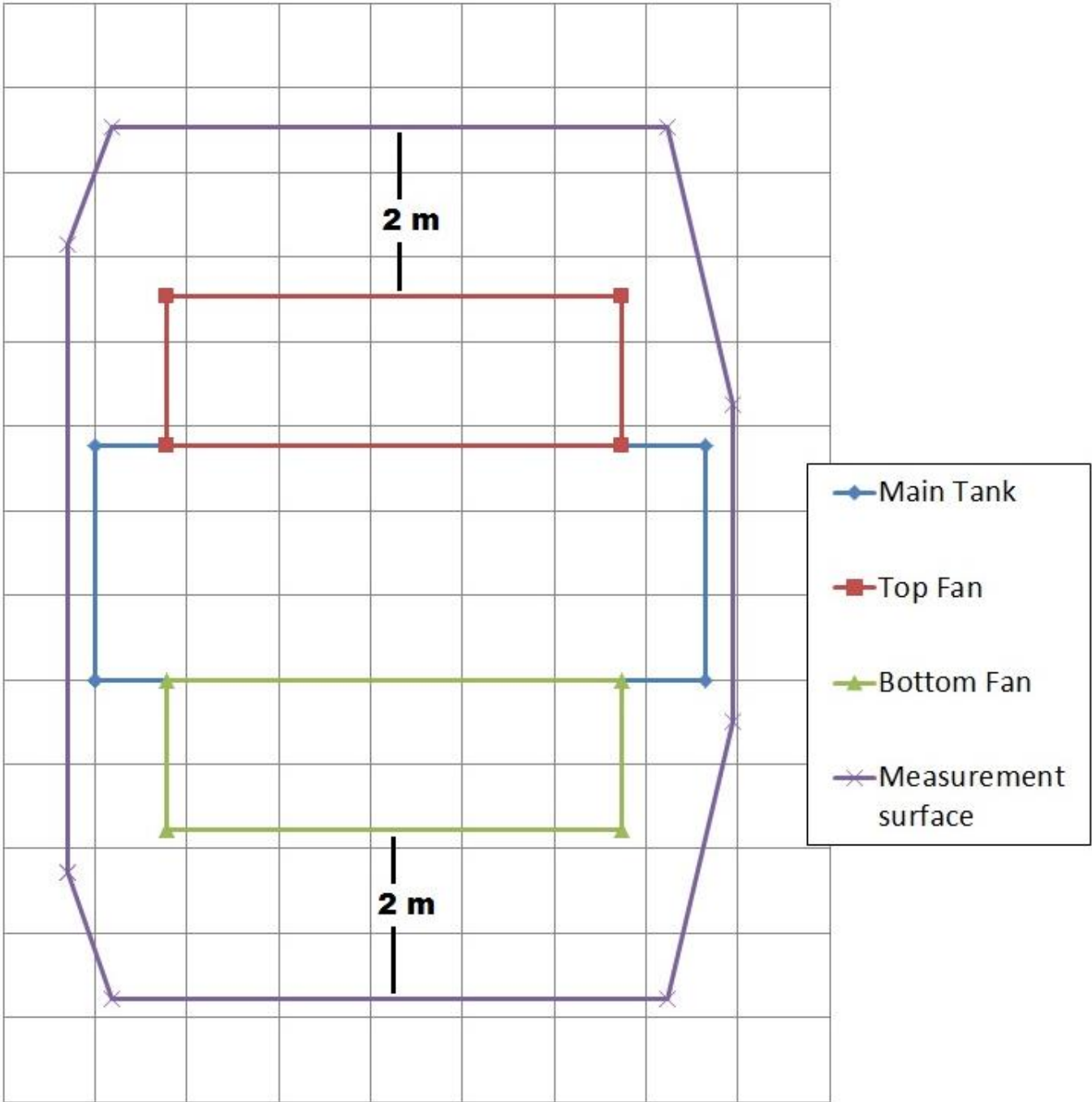

Romney transformer – diagram of sound measurement surface area, as per IEEE C57.12.9

BBA COMPLIANCE VERIFICATION

SCOPE OF VERIFICATION

TECHNICAL COMPLIANCE IN RELATION TO CONTRACTUAL REQUIREMENTS

OTHERS:

REF:

FINDING

REFER TO COMMENTS ON THE DOCUMENT

OTHERS:

REF:

RECOMMENDATION

WORK MAY PROCEED.

REVISE & RESUBMIT, WORK MAY PROCEED SUBJECT TO INCORPORATION OF CHANGES.

REVISE & RESUBMIT, WORK MAY NOT PROCEED.

REVIEW NOT REQUIRED, WORK MAY PROCEED.

CANCELLED/SUPERSEDED.

2015-02-02

SIGNATURE: *Samuel Gendron* DATE: 140671

NAME: Samuel Gendron, eng. MEMBER NO.:

THE VERIFICATION IS RESTRICTED TO THE ONE INDICATED AND DOES NOT IN ANY WAY CONSIST OF A DETAILED AND COMPLETE DESIGN VERIFICATION. IT DOES NOT IN ANY WAY RELEASE THE PERSON OR COMPANY WHO PREPARED IT FROM HIS OR ITS OBLIGATIONS OF ANY NATURE WHATSOEVER. MD140503X_REV0

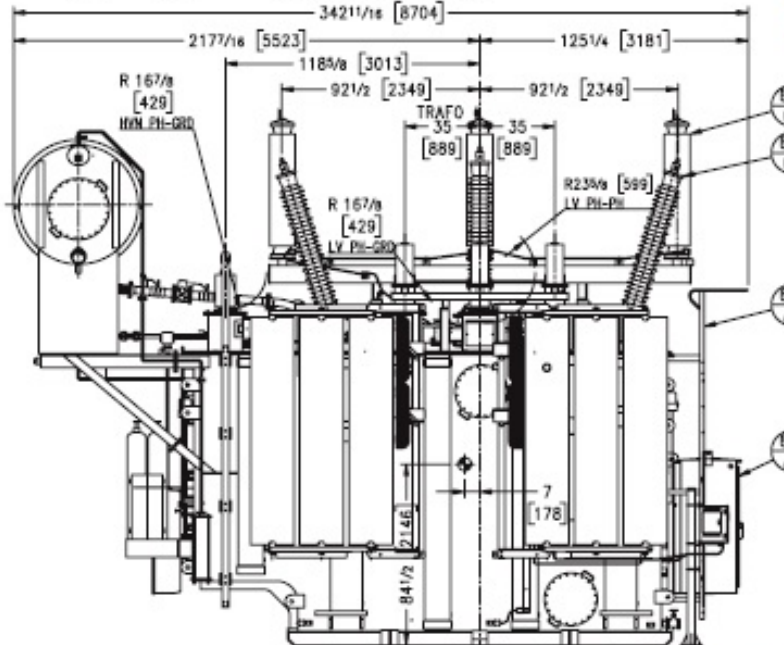
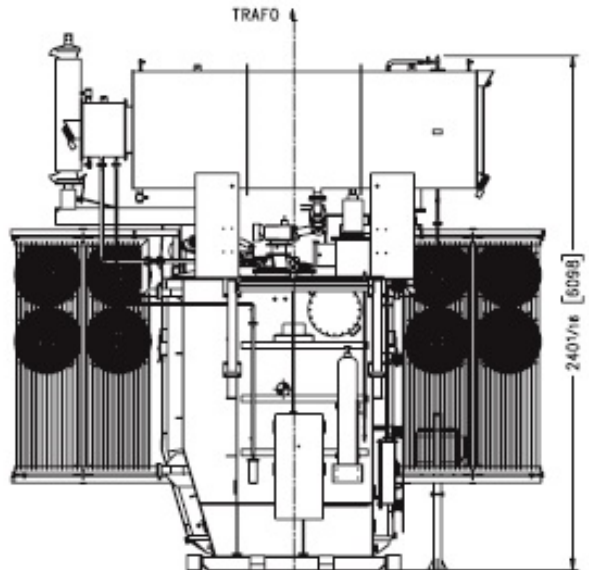
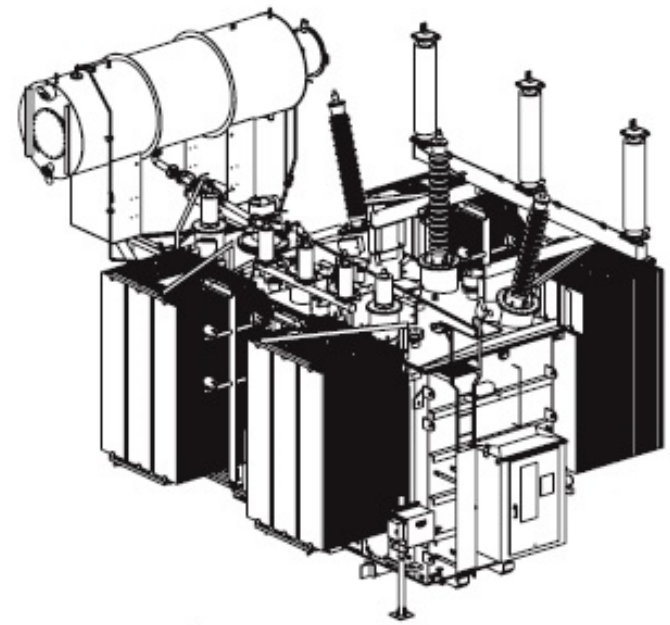
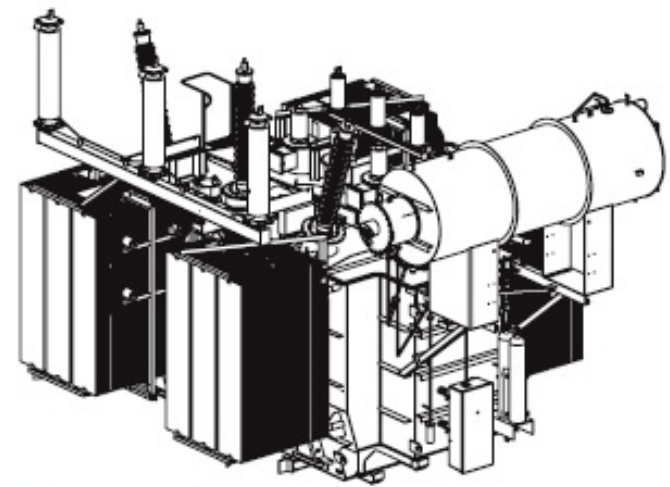
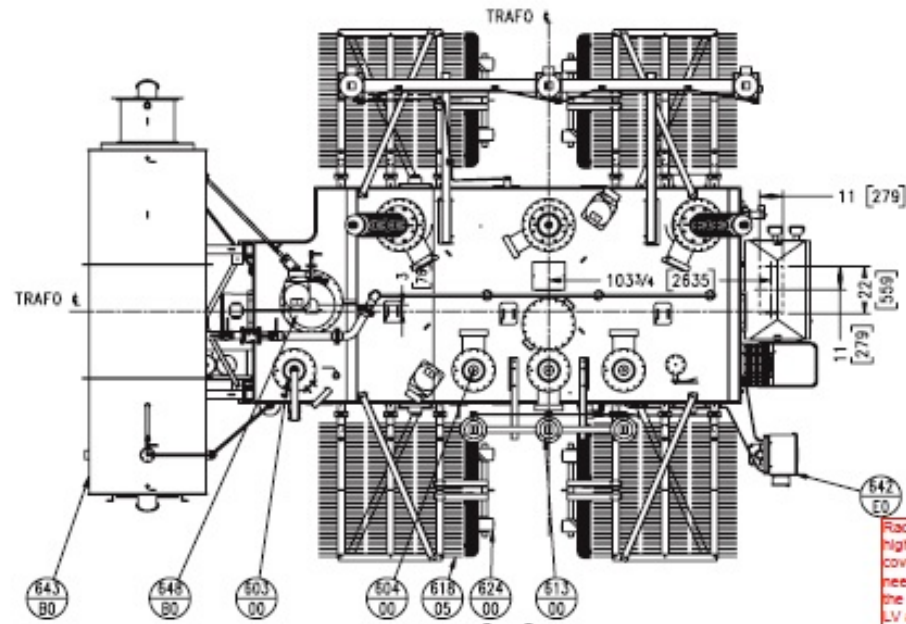

Radiators are higher than the tank cover. We would need to have both the LV bushing and LV arresters pads at the same height.

Please show bushings tin-plated terminal pads on drawing and item list below.

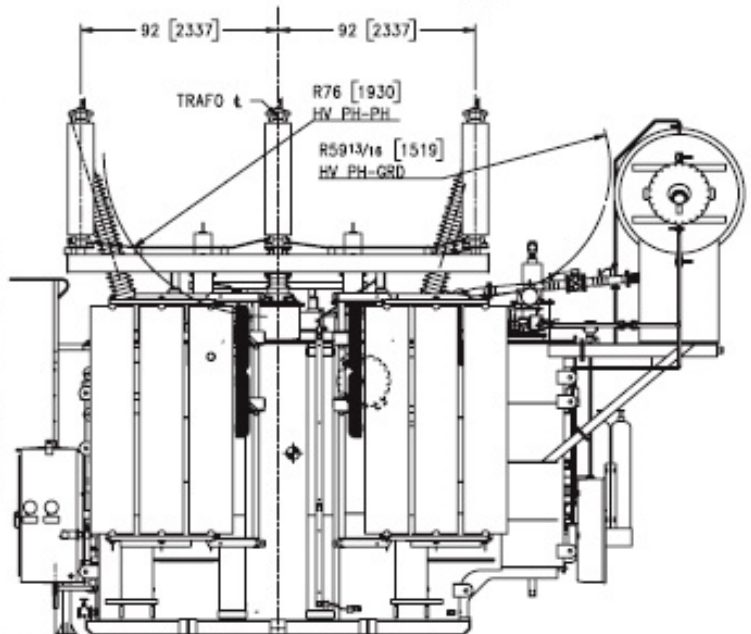
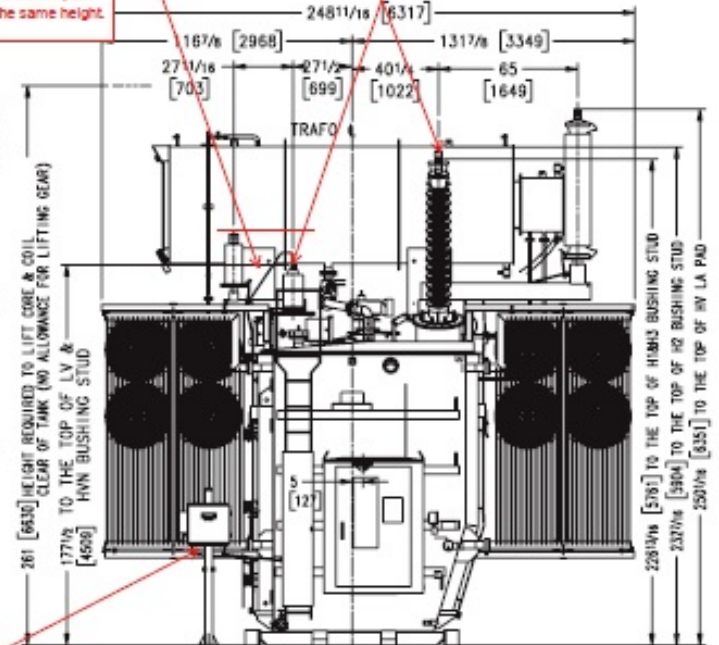

Is it possible to install the Calisto 5 on the transformer, instead of having its own support?

We understand that this drawing is preliminary, and that the next revision will have more details. For example: the list of materials is very short.

NOTE:
1. ALL DIMENSIONS ARE IN INCHES [MM] UNLESS OTHERWISE STATED.
2. ALL DETAILS IN THIS DRAWING WILL BE INCORPORATED IN OUTLINE DRAWINGS MD140503 & MA140503C.

ITEM NO	DESCRIPTION
TM-602.00	Three (3) HV Bushing 161 kV, 750 Amp, 800 kV BIL PCORE Identification # POC750G08005 To ANSI STD Top Stud 1 1/2"-12 TPI x 56.8 mm (2") Long, Bulletin # 580
TM-603.00	HVN Bushing 34.5 kV, 2000Amp, 200 kV BIL PCORE Identification # B-89323-70 To ANSI STD Top Stud 2"-12 TPI x 54 mm (2 1/8") Long, Bull
TM-604.00	Three (3) LV Bushing 34.5 kV, 3000 Amp, 200 kV BIL PCORE Identification # B-88833-70 To ANSI STD Top Stud 2"-12 TPI x 54mm (2 1/8") Long, Bulletin # 580
TM-612.00	Three (3) HV Surge Arrester 144 kV, 115 kV MCOV ABB Cat. #P144GA115A
TM-613.00	Three (3) LV Surge Arrester 30 kV, 24.4 kV MCOV ABB Cat. Q030SA024A
TM-618.05	Twelve (12) Removable Type Radiators (MENK)
TM-624.00	Sixteen (16) Weatherproof Cooling Fans 240/3/60, 1/3 HP, 1140 RPM, With Permanently Lubricated Sealed Bearings Krenz-Vent Part No. F
TM-642.E0	Morgan-Schaffer Hydrogen, Carbon Monoxide Detector Model # CALISTO 5 c/w Two 1/2" NPS Ball Valves & Pedestal Mounting
643.80	Transformer Conservator Air Bag Type 1371.6mm (54") Diameter x 4064mm (160") Long Sloped 25mm Towards Drain Valve End
644.A0	Weatherproof Control Cabinet 1186mm (46") Wide x 1575mm (62") High x 950mm (38") Deep, For All Auxiliary Wiring
648.80	Load Tap-changer M-R Type VM III 500Y 72.5/B-18353WR
661.A0	Ladder With Barrier And Provision For Pedlocking To Prevent Access By Unauthorized Persons c/w Handhold And Safety Wind Stop On Barrier To Lock In 160° Open Position (Painted Yellow)

MVA : 54/72/90	HV: 161 000 V GRD Y/92 853 V
TYPE: ONAN/ONAF/ONAF	LV: 34 500 V Y/19 820 V
PHASE:3	HV TAPS: A15 IN x 16 STEPS
FREQUENCY: 60Hz	LV TAPS: -
TEMPERATURE RISE:65° C	TEXT: -
CORE & COILS ASSY: 105 000 LBS	OIL: 85 600 LBS
TANK & FITTINGS: 72 600 LBS	TOTAL: 243 200 LBS
TOTAL OIL QTY : 35070 LITRES	

LIFTING AND JACKING STEPS LOADING		
D HV WALL C	LUG-A: 72 400 LBS	STEP-A: 81 400 LBS
	LUG-B: 54 900 LBS	STEP-B: 46 800 LBS
	LUG-C: 50 000 LBS	STEP-C: 58 300 LBS
A LV WALL B	LUG-D: 85 900 LBS	STEP-D: 76 900 LBS

ENGINEER: VDJ DATE: 30-JAN-15

CHECKED: DATE: 30-JAN-15

APP'D: DATE: 30-JAN-15

CONTRACTOR: CONSTRUCTION ENERGIE RENOUVELABLE

CUSTOMER REF: RA14.0003

P.O. NUMBER: 16707-00

LOCATION: WOODBRIAR DC

PROJECT NAME: RA140503/UG/

PILOT SCALE: 1=42

PRODUCTION: [Symbol]

DATE: 30-JAN-15

PAGE 1 OF 1

PRELIMINARY OUTLINE FOR CIVIL WORKS

MD140503X

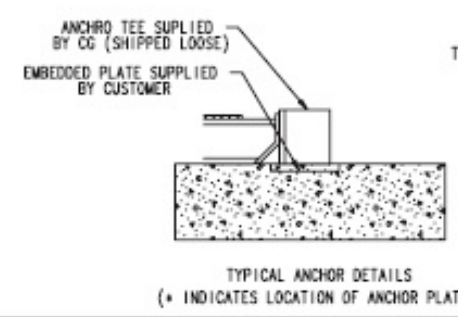



ABOUT DNV GL

Driven by our purpose of safeguarding life, property and the environment, DNV GL enables organizations to advance the safety and sustainability of their business. We provide classification, technical assurance, software and independent expert advisory services to the maritime, oil & gas and energy industries. We also provide certification services to customers across a wide range of industries. Combining leading technical and operational expertise, risk methodology and in-depth industry knowledge, we empower our customers' decisions and actions with trust and confidence. We continuously invest in research and collaborative innovation to provide customers and society with operational and technological foresight. Operating in more than 100 countries, our professionals are dedicated to helping customers make the world safer, smarter and greener.